

Solutionbank C2

Edexcel Modular Mathematics for AS and A-Level

Algebra and functions

Exercise A, Question 1

Question:

Simplify these fractions:

$$(a) \frac{4x^4 + 5x^2 - 7x}{x}$$

$$(b) \frac{7x^8 - 5x^5 + 9x^3 + x^2}{x}$$

$$(c) \frac{-2x^3 + x}{x}$$

$$(d) \frac{-x^4 + 4x^2 + 6}{x}$$

$$(e) \frac{7x^5 - x^3 - 4}{x}$$

$$(f) \frac{8x^4 - 4x^3 + 6x}{2x}$$

$$(g) \frac{9x^2 - 12x^3 - 3x}{3x}$$

$$(h) \frac{8x^5 - 2x^3}{4x}$$

$$(i) \frac{7x^3 - x^4 - 2}{5x}$$

$$(j) \frac{-4x^2 + 6x^4 - 2x}{-2x}$$

$$(k) \frac{-x^8 + 9x^4 + 6}{-2x}$$

$$(l) \frac{-9x^9 - 6x^4 - 2}{-3x}$$

Solution:

$$(a) \frac{4x^4 + 5x^2 - 7x}{x} = \frac{4x^4}{x} + \frac{5x^2}{x} - \frac{7x}{x} = 4x^3 + 5x - 7$$

$$(b) \frac{7x^8 - 5x^5 + 9x^3 + x^2}{x} = \frac{7x^8}{x} - \frac{5x^5}{x} + \frac{9x^3}{x} + \frac{x^2}{x} = 7x^7 - 5x^4 + 9x^2 + x$$

$$(c) \frac{-2x^3 + x}{x} = \frac{-2x^3}{x} + \frac{x}{x} = -2x^2 + 1$$

$$(d) \frac{-x^4 + 4x^2 + 6}{x} = \frac{-x^4}{x} + \frac{4x^2}{x} + \frac{6}{x} = -x^3 + 4x + \frac{6}{x}$$

$$(e) \frac{7x^5 - x^3 - 4}{x} = \frac{7x^5}{x} - \frac{x^3}{x} - \frac{4}{x} = 7x^4 - x^2 - \frac{4}{x}$$

$$(f) \frac{8x^4 - 4x^3 + 6x}{2x} = \frac{8x^4}{2x} - \frac{4x^3}{2x} + \frac{6x}{2x} = 4x^3 - 2x^2 + 3$$

$$(g) \frac{9x^2 - 12x^3 - 3x}{3x} = \frac{9x^2}{3x} - \frac{12x^3}{3x} - \frac{3x}{3x} = 3x - 4x^2 - 1$$

$$(h) \frac{8x^5 - 2x^3}{4x} = \frac{8x^5}{4x} - \frac{2x^3}{4x} = 2x^4 - \frac{x^2}{2}$$

$$(i) \frac{7x^3 - x^4 - 2}{5x} = \frac{7x^3}{5x} - \frac{x^4}{5x} - \frac{2}{5x} = \frac{7x^2}{5} - \frac{x^3}{5} - \frac{2}{5x}$$

$$(j) \frac{-4x^2 + 6x^4 - 2x}{-2x} = \frac{-4x^2}{-2x} + \frac{6x^4}{-2x} - \frac{2x}{-2x}$$

$$= \frac{2x^2}{x} - \frac{3x^4}{x} + 1$$

$$= 2x - 3x^3 + 1$$

$$(k) \frac{-x^8 + 9x^4 + 6}{-2x} = \frac{-x^8}{-2x} + \frac{9x^4}{-2x} + \frac{6}{-2x}$$

$$= \frac{x^8}{2x} - \frac{9x^4}{2x} - \frac{3}{x}$$

$$= \frac{x^7}{2} - \frac{9x^3}{2} - \frac{3}{x}$$

$$(l) \frac{-9x^9 - 6x^4 - 2}{-3x} = \frac{-9x^9}{-3x} - \frac{6x^4}{-3x} - \frac{2}{-3x}$$

$$= \frac{3x^9}{x} + \frac{2x^4}{x} + \frac{2}{3x}$$

$$= 3x^8 + 2x^3 + \frac{2}{3x}$$

© Pearson Education Ltd 2008

Solutionbank C2

Edexcel Modular Mathematics for AS and A-Level

Algebra and functions

Exercise A, Question 2

Question:

Simplify these fractions as far as possible:

$$(a) \frac{(x+3)(x-2)}{(x-2)}$$

$$(b) \frac{(x+4)(3x-1)}{(3x-1)}$$

$$(c) \frac{(x+3)^2}{(x+3)}$$

$$(d) \frac{x^2+10x+21}{(x+3)}$$

$$(e) \frac{x^2+9x+20}{(x+4)}$$

$$(f) \frac{x^2+x-12}{(x-3)}$$

$$(g) \frac{x^2+x-20}{x^2+2x-15}$$

$$(h) \frac{x^2+3x+2}{x^2+5x+4}$$

$$(i) \frac{x^2+x-12}{x^2-9x+18}$$

$$(j) \frac{2x^2+7x+6}{(x-5)(x+2)}$$

$$(k) \frac{2x^2+9x-18}{(x+6)(x+1)}$$

$$(l) \frac{3x^2-7x+2}{(3x-1)(x+2)}$$

$$(m) \frac{2x^2+3x+1}{x^2-x-2}$$

$$(n) \frac{x^2 + 6x + 8}{3x^2 + 7x + 2}$$

$$(o) \frac{2x^2 - 5x - 3}{2x^2 - 9x + 9}$$

Solution:

$$(a) \frac{(x+3)(x-2)}{(x-2)}$$

$$= \frac{(x+3)\cancel{(x-2)}}{\cancel{(x-2)}}$$

$$= x + 3$$

$$(b) \frac{(x+4)(3x-1)}{(3x-1)}$$

$$= \frac{(x+4)\cancel{(3x-1)}}{\cancel{(3x-1)}}$$

$$= x + 4$$

$$(c) \frac{(x+3)^2}{(x+3)}$$

$$= \frac{(x+3)\cancel{(x+3)}}{\cancel{(x+3)}}$$

$$= x + 3$$

$$(d) \frac{x^2 + 10x + 21}{x+3}$$

$$= \frac{(x+7)\cancel{(x+3)}}{\cancel{(x+3)}}$$

$$= x + 7$$

$$(e) \frac{x^2 + 9x + 20}{x+4}$$

$$= \frac{(x+4)\cancel{(x+5)}}{\cancel{(x+4)}}$$

$$= x + 5$$

$$(f) \frac{x^2 + x - 12}{x-3}$$

$$= \frac{(x-3)(x+4)}{(x-3)}$$

$$= x + 4$$

$$(g) \frac{x^2 + x - 20}{x^2 + 2x - 15}$$

$$= \frac{(x+5)(x-4)}{(x+5)(x-3)}$$

$$= \frac{x-4}{x-3}$$

$$(h) \frac{x^2 + 3x + 2}{x^2 + 5x + 4}$$

$$= \frac{(x+2)(x+1)}{(x+4)(x+1)}$$

$$= \frac{x+2}{x+4}$$

$$(i) \frac{x^2 + x - 12}{x^2 - 9x + 18}$$

$$= \frac{(x+4)(x-3)}{(x-6)(x-3)}$$

$$= \frac{x+4}{x-6}$$

$$(j) \frac{2x^2 + 7x + 6}{(x-5)(x+2)}$$

$$= \frac{(2x+3)(x+2)}{(x-5)(x+2)}$$

$$= \frac{2x+3}{x-5}$$

$$(k) \frac{2x^2 + 9x - 18}{(x+6)(x+1)}$$

$$= \frac{(2x-3)(x+6)}{(x+6)(x+1)}$$

$$= \frac{2x-3}{x+1}$$

$$(l) \frac{3x^2 - 7x + 2}{(3x - 1)(x + 2)}$$

$$= \frac{\cancel{(3x-1)}(x-2)}{\cancel{(3x-1)}(x+2)}$$

$$= \frac{x-2}{x+2}$$

$$(m) \frac{2x^2 + 3x + 1}{x^2 - x - 2}$$

$$= \frac{\cancel{(2x+1)}\cancel{(x+1)}}{\cancel{(x-2)}\cancel{(x+1)}}$$

$$= \frac{2x+1}{x-2}$$

$$(n) \frac{x^2 + 6x + 8}{3x^2 + 7x + 2}$$

$$= \frac{\cancel{(x+4)}\cancel{(x+2)}}{\cancel{(3x+1)}\cancel{(x+2)}}$$

$$= \frac{x+4}{3x+1}$$

$$(o) \frac{2x^2 - 5x - 3}{2x^2 - 9x + 9}$$

$$= \frac{\cancel{(2x+1)}\cancel{(x-3)}}{\cancel{(2x-3)}\cancel{(x-3)}}$$

$$= \frac{2x+1}{2x-3}$$

© Pearson Education Ltd 2008

Solutionbank C2

Edexcel Modular Mathematics for AS and A-Level

Algebra and functions

Exercise B, Question 1

Question:

Divide:

(a) $x^3 + 6x^2 + 8x + 3$ by $(x + 1)$

(b) $x^3 + 10x^2 + 25x + 4$ by $(x + 4)$

(c) $x^3 + 7x^2 - 3x - 54$ by $(x + 6)$

(d) $x^3 + 9x^2 + 18x - 10$ by $(x + 5)$

(e) $x^3 - x^2 + x + 14$ by $(x + 2)$

(f) $x^3 + x^2 - 7x - 15$ by $(x - 3)$

(g) $x^3 - 5x^2 + 8x - 4$ by $(x - 2)$

(h) $x^3 - 3x^2 + 8x - 6$ by $(x - 1)$

(i) $x^3 - 8x^2 + 13x + 10$ by $(x - 5)$

(j) $x^3 - 5x^2 - 6x - 56$ by $(x - 7)$

Solution:

$$\begin{array}{r}
 x^2 + 5x + 3 \\
 x + 1 \overline{) x^3 + 6x^2 + 8x + 3} \\
 \underline{x^3 + x^2} \\
 5x^2 + 8x \\
 \underline{5x^2 + 5x} \\
 3x + 3 \\
 \underline{3x + 3} \\
 0
 \end{array}$$

Answer is $x^2 + 5x + 3$

$$\begin{array}{r}
 x^2 + 6x + 1 \\
 x + 4 \overline{) x^3 + 10x^2 + 25x + 4} \\
 \underline{x^3 + 4x^2} \\
 6x^2 + 25x \\
 \underline{6x^2 + 24x} \\
 x + 4 \\
 \underline{x + 4} \\
 0
 \end{array}$$

(b)

Answer is $x^2 + 6x + 1$

$$\begin{array}{r}
 x^2 + x - 9 \\
 x + 6 \overline{) x^3 + 7x^2 - 3x - 54} \\
 \underline{x^3 + 6x^2} \\
 x^2 - 3x \\
 \underline{x^2 + 6x} \\
 -9x - 54 \\
 \underline{-9x - 54} \\
 0
 \end{array}$$

(c)

Answer is $x^2 + x - 9$

$$\begin{array}{r}
 x^2 + 4x - 2 \\
 x + 5 \overline{) x^3 + 9x^2 + 18x - 10} \\
 \underline{x^3 + 5x^2} \\
 4x^2 + 18x \\
 \underline{4x^2 + 20x} \\
 -2x - 10 \\
 \underline{-2x - 10} \\
 0
 \end{array}$$

(d)

Answer is $x^2 + 4x - 2$

$$\begin{array}{r}
 x^2 - 3x + 7 \\
 x + 2 \overline{) x^3 - x^2 + x + 14} \\
 \underline{x^3 + 2x^2} \\
 -3x^2 + x \\
 \underline{-3x^2 - 6x} \\
 7x + 14 \\
 \underline{7x + 14} \\
 0
 \end{array}$$

(e)

Answer is $x^2 - 3x + 7$

$$\begin{array}{r}
 x^2 + 4x + 5 \\
 x - 3 \overline{) x^3 + x^2 - 7x - 15} \\
 \underline{x^3 - 3x^2} \\
 4x^2 - 7x \\
 \underline{4x^2 - 12x} \\
 5x - 15 \\
 \underline{5x - 15} \\
 0
 \end{array}$$

(f)

Answer is $x^2 + 4x + 5$

$$\begin{array}{r}
 x^2 - 3x + 2 \\
 x - 2 \overline{) x^3 - 5x^2 + 8x - 4} \\
 \underline{x^3 - 2x^2} \\
 -3x^2 + 8x \\
 \underline{-3x^2 + 6x} \\
 2x - 4 \\
 \underline{2x - 4} \\
 0
 \end{array}$$

(g)

Answer is $x^2 - 3x + 2$

$$\begin{array}{r}
 x^2 - 2x + 6 \\
 x - 1 \overline{) x^3 - 3x^2 + 8x - 6} \\
 \underline{x^3 - x^2} \\
 -2x^2 + 8x \\
 \underline{-2x^2 + 2x} \\
 6x - 6 \\
 \underline{6x - 6} \\
 0
 \end{array}$$

(h)

Answer is $x^2 - 2x + 6$

$$\begin{array}{r}
 x^2 - 3x - 2 \\
 x - 5 \overline{) x^3 - 8x^2 + 13x + 10} \\
 \underline{x^3 - 5x^2} \\
 -3x^2 + 13x \\
 \underline{-3x^2 + 15x} \\
 -2x + 10 \\
 \underline{-2x + 10} \\
 0
 \end{array}$$

(i)

Answer is $x^2 - 3x - 2$

$$\begin{array}{r}
 x^2 + 2x + 8 \\
 x - 7 \overline{) x^3 - 5x^2 - 6x - 56} \\
 \underline{x^3 - 7x^2} \\
 2x^2 - 6x \\
 \underline{2x^2 - 14x} \\
 8x - 56 \\
 \underline{8x - 56} \\
 0
 \end{array}$$

Answer is $x^2 + 2x + 8$

© Pearson Education Ltd 2008

Solutionbank C2

Edexcel Modular Mathematics for AS and A-Level

Algebra and functions

Exercise B, Question 2

Question:

Divide:

(a) $6x^3 + 27x^2 + 14x + 8$ by $(x + 4)$

(b) $4x^3 + 9x^2 - 3x - 10$ by $(x + 2)$

(c) $3x^3 - 10x^2 - 10x + 8$ by $(x - 4)$

(d) $3x^3 - 5x^2 - 4x - 24$ by $(x - 3)$

(e) $2x^3 + 4x^2 - 9x - 9$ by $(x + 3)$

(f) $2x^3 - 15x^2 + 14x + 24$ by $(x - 6)$

(g) $-3x^3 + 2x^2 - 2x - 7$ by $(x + 1)$

(h) $-2x^3 + 5x^2 + 17x - 20$ by $(x - 4)$

(i) $-5x^3 - 27x^2 + 23x + 30$ by $(x + 6)$

(j) $-4x^3 + 9x^2 - 3x + 2$ by $(x - 2)$

Solution:

$$\begin{array}{r}
 \overline{6x^2 + 3x + 2} \\
 x + 4 \overline{) 6x^3 + 27x^2 + 14x + 8} \\
 \underline{6x^3 + 24x^2} \\
 3x^2 + 14x \\
 \underline{3x^2 + 12x} \\
 2x + 8 \\
 \underline{2x + 8} \\
 0
 \end{array}$$

Answer is $6x^2 + 3x + 2$

$$\begin{array}{r}
 4x^2 + x - 5 \\
 x + 2 \overline{) 4x^3 + 9x^2 - 3x - 10} \\
 \underline{4x^3 + 8x^2} \\
 x^2 - 3x \\
 \underline{x^2 + 2x} \\
 -5x - 10 \\
 \underline{-5x - 10} \\
 0
 \end{array}$$

(b)

Answer is $4x^2 + x - 5$

$$\begin{array}{r}
 3x^2 + 2x - 2 \\
 x - 4 \overline{) 3x^3 - 10x^2 - 10x + 8} \\
 \underline{3x^3 - 12x^2} \\
 2x^2 - 10x \\
 \underline{2x^2 - 8x} \\
 -2x + 8 \\
 \underline{-2x + 8} \\
 0
 \end{array}$$

(c)

Answer is $3x^2 + 2x - 2$

$$\begin{array}{r}
 3x^2 + 4x + 8 \\
 x - 3 \overline{) 3x^3 - 5x^2 - 4x - 24} \\
 \underline{3x^3 - 9x^2} \\
 4x^2 - 4x \\
 \underline{4x^2 - 12x} \\
 8x - 24 \\
 \underline{8x - 24} \\
 0
 \end{array}$$

(d)

Answer is $3x^2 + 4x + 8$

$$\begin{array}{r}
 2x^2 - 2x - 3 \\
 x + 3 \overline{) 2x^3 + 4x^2 - 9x - 9} \\
 \underline{2x^3 + 6x^2} \\
 -2x^2 - 9x \\
 \underline{-2x^2 - 6x} \\
 -3x - 9 \\
 \underline{-3x - 9} \\
 0
 \end{array}$$

(e)

Answer is $2x^2 - 2x - 3$

$$\begin{array}{r}
 2x^2 - 3x - 4 \\
 x - 6 \overline{) 2x^3 - 15x^2 + 14x + 24} \\
 \underline{2x^3 - 12x^2} \\
 -3x^2 + 14x \\
 \underline{-3x^2 + 18x} \\
 -4x + 24 \\
 \underline{-4x + 24} \\
 0
 \end{array}$$

(f)

Answer is $2x^2 - 3x - 4$

$$\begin{array}{r}
 -3x^2 + 5x - 7 \\
 x + 1 \overline{) -3x^3 + 2x^2 - 2x - 7} \\
 \underline{-3x^3 - 3x^2} \\
 5x^2 - 2x \\
 \underline{5x^2 + 5x} \\
 -7x - 7 \\
 \underline{-7x - 7} \\
 0
 \end{array}$$

(g)

Answer is $-3x^2 + 5x - 7$

$$\begin{array}{r}
 -2x^2 - 3x + 5 \\
 x - 4 \overline{) -2x^3 + 5x^2 + 17x - 20} \\
 \underline{-2x^3 + 8x^2} \\
 -3x^2 + 17x \\
 \underline{-3x^2 + 12x} \\
 5x - 20 \\
 \underline{5x - 20} \\
 0
 \end{array}$$

(h)

Answer is $-2x^2 - 3x + 5$

$$\begin{array}{r}
 -5x^2 + 3x + 5 \\
 x + 6 \overline{) -5x^3 - 27x^2 + 23x + 30} \\
 \underline{-5x^3 - 30x^2} \\
 3x^2 + 23x \\
 \underline{3x^2 + 18x} \\
 5x + 30 \\
 \underline{5x + 30} \\
 0
 \end{array}$$

(i)

Answer is $-5x^2 + 3x + 5$

$$\begin{array}{r}
 \overline{-4x^2 + x - 1} \\
 x - 2 \overline{) -4x^3 + 9x^2 - 3x + 2} \\
 \underline{-4x^3 + 8x^2} \\
 x^2 - 3x \\
 \underline{x^2 - 2x} \\
 -x + 2 \\
 \underline{-x + 2} \\
 0
 \end{array}$$

Answer is $-4x^2 + x - 1$

© Pearson Education Ltd 2008

Solutionbank C2

Edexcel Modular Mathematics for AS and A-Level

Algebra and functions

Exercise B, Question 3

Question:

Divide:

(a) $x^4 + 5x^3 + 2x^2 - 7x + 2$ by $(x + 2)$

(b) $x^4 + 11x^3 + 25x^2 - 29x - 20$ by $(x + 5)$

(c) $4x^4 + 14x^3 + 3x^2 - 14x - 15$ by $(x + 3)$

(d) $3x^4 - 7x^3 - 23x^2 + 14x - 8$ by $(x - 4)$

(e) $-3x^4 + 9x^3 - 10x^2 + x + 14$ by $(x - 2)$

(f) $3x^5 + 17x^4 + 2x^3 - 38x^2 + 5x - 25$ by $(x + 5)$

(g) $6x^5 - 19x^4 + x^3 + x^2 + 13x + 6$ by $(x - 3)$

(h) $-5x^5 + 7x^4 + 2x^3 - 7x^2 + 10x - 7$ by $(x - 1)$

(i) $2x^6 - 11x^5 + 14x^4 - 16x^3 + 36x^2 - 10x - 24$ by $(x - 4)$

(j) $-x^6 + 4x^5 - 4x^4 + 4x^3 - 5x^2 + 7x - 3$ by $(x - 3)$

Solution:

$$\begin{array}{r}
 x^3 + 3x^2 - 4x + 1 \\
 x + 2 \overline{) x^4 + 5x^3 + 2x^2 - 7x + 2} \\
 \underline{x^4 + 2x^3} \\
 3x^3 + 2x^2 \\
 \underline{3x^3 + 6x^2} \\
 -4x^2 - 7x + 2 \\
 \underline{-4x^2 - 8x} \\
 x + 2 + 2 \\
 \underline{x + 2} \\
 0
 \end{array}$$

Answer is $x^3 + 3x^2 - 4x + 1$

$$\begin{array}{r}
 x^3 + 6x^2 - 5x - 4 \\
 x + 5 \overline{) x^4 + 11x^3 + 25x^2 - 29x - 20} \\
 \underline{x^4 + 5x^3} \\
 6x^3 + 25x^2 \\
 \underline{6x^3 + 30x^2} \\
 -5x^2 - 29x - 20 \\
 \underline{-5x^2 - 25x} \\
 -4x - 20 \\
 \underline{-4x - 20} \\
 0
 \end{array}$$

(b)

Answer is $x^3 + 6x^2 - 5x - 4$

$$\begin{array}{r}
 4x^3 + 2x^2 - 3x - 5 \\
 x + 3 \overline{) 4x^4 + 14x^3 + 3x^2 - 14x - 15} \\
 \underline{4x^4 + 12x^3} \\
 2x^3 + 3x^2 \\
 \underline{2x^3 + 6x^2} \\
 -3x^2 - 14x - 15 \\
 \underline{-3x^2 - 9x} \\
 -5x - 15 \\
 \underline{-5x - 15} \\
 0
 \end{array}$$

(c)

Answer is $4x^3 + 2x^2 - 3x - 5$

$$\begin{array}{r}
 3x^3 + 5x^2 - 3x + 2 \\
 x - 4 \overline{) 3x^4 - 7x^3 - 23x^2 + 14x - 8} \\
 \underline{3x^4 - 12x^3} \\
 5x^3 - 23x^2 \\
 \underline{5x^3 - 20x^2} \\
 -3x^2 + 14x - 8 \\
 \underline{-3x^2 + 12x} \\
 2x - 8 \\
 \underline{2x - 8} \\
 0
 \end{array}$$

(d)

Answer is $3x^3 + 5x^2 - 3x + 2$

$$\begin{array}{r}
 -3x^3 + 3x^2 \quad - \quad 4x - 7 \\
 x - 2 \overline{) -3x^4 + 9x^3 - 10x^2 + \quad x + 14} \\
 \underline{-3x^4 + 6x^3} \\
 3x^3 - 10x^2 \\
 \underline{3x^3 - 6x^2} \\
 -4x^2 + \quad x \\
 \underline{-4x^2 + 8x} \\
 -7x + 14 \\
 \underline{-7x + 14} \\
 0
 \end{array}$$

(e)

Answer is $-3x^3 + 3x^2 - 4x - 7$

$$\begin{array}{r}
 3x^4 + 2x^3 \quad - \quad 8x^2 + 2x - 5 \\
 x + 5 \overline{) 3x^5 + 17x^4 + \quad 2x^3 - 38x^2 + \quad 5x - 25} \\
 \underline{3x^5 + 15x^4} \\
 2x^4 + \quad 2x^3 \\
 \underline{2x^4 + 10x^3} \\
 -8x^3 - 38x^2 \\
 \underline{-8x^3 - 40x^2} \\
 2x^2 + \quad 5x \\
 \underline{2x^2 + 10x} \\
 -5x - 25 \\
 \underline{-5x - 25} \\
 0
 \end{array}$$

(f)

Answer is $3x^4 + 2x^3 - 8x^2 + 2x - 5$

$$\begin{array}{r}
 6x^4 - x^3 \quad - \quad 2x^2 - 5x - 2 \\
 x - 3 \overline{) 6x^5 - 19x^4 + x^3 + \quad x^2 + 13x + 6} \\
 \underline{6x^5 - 18x^4} \\
 -x^4 + x^3 \\
 \underline{-x^4 + 3x^3} \\
 -2x^3 + \quad x^2 \\
 \underline{-2x^3 + 6x^2} \\
 -5x^2 + 13x \\
 \underline{-5x^2 + 15x} \\
 -2x + 6 \\
 \underline{-2x + 6} \\
 0
 \end{array}$$

(g)

Answer is $6x^4 - x^3 - 2x^2 - 5x - 2$

$$\begin{array}{r}
 -5x^4 + 2x^3 + 4x^2 - 3x + 7 \\
 x - 1 \overline{) -5x^5 + 7x^4 + 2x^3 - 7x^2 + 10x - 7} \\
 \underline{-5x^5 + 5x^4} \\
 2x^4 + 2x^3 \\
 \underline{2x^4 - 2x^3} \\
 4x^3 - 7x^2 \\
 \underline{4x^3 - 4x^2} \\
 -3x^2 + 10x - 7 \\
 \underline{-3x^2 + 3x} \\
 7x - 7 \\
 \underline{7x - 7} \\
 0
 \end{array}$$

(h)

Answer is $-5x^4 + 2x^3 + 4x^2 - 3x + 7$

$$\begin{array}{r}
 2x^5 - 3x^4 + 2x^3 - 8x^2 + 4x + 6 \\
 x - 4 \overline{) 2x^6 - 11x^5 + 14x^4 - 16x^3 + 36x^2 - 10x - 24} \\
 \underline{2x^6 - 8x^5} \\
 -3x^5 + 14x^4 \\
 \underline{-3x^5 + 12x^4} \\
 2x^4 - 16x^3 \\
 \underline{2x^4 - 8x^3} \\
 -8x^3 + 36x^2 \\
 \underline{-8x^3 + 32x^2} \\
 4x^2 - 10x - 24 \\
 \underline{4x^2 - 16x} \\
 6x - 24 \\
 \underline{6x - 24} \\
 0
 \end{array}$$

(i)

Answer is $2x^5 - 3x^4 + 2x^3 - 8x^2 + 4x + 6$

$$\begin{array}{r}
 -x^5 + x^4 \quad - \quad x^3 + x^2 - 2x + 1 \\
 x - 3 \overline{) -x^6 + 4x^5 - 4x^4 + 4x^3 - 5x^2 + 7x - 3} \\
 \underline{-x^6 + 3x^5} \\
 x^5 - 4x^4 \\
 \underline{x^5 - 3x^4} \\
 -x^4 + 4x^3 \\
 \underline{-x^4 + 3x^3} \\
 x^3 - 5x^2 \\
 \underline{x^3 - 3x^2} \\
 -2x^2 + 7x \\
 \underline{-2x^2 + 6x} \\
 x - 3 \\
 \underline{x - 3} \\
 0
 \end{array}$$

Answer is $-x^5 + x^4 - x^3 + x^2 - 2x + 1$

© Pearson Education Ltd 2008

Solutionbank C2

Edexcel Modular Mathematics for AS and A-Level

Algebra and functions

Exercise C, Question 1

Question:

Divide:

(a) $x^3 + x + 10$ by $(x + 2)$

(b) $2x^3 - 17x + 3$ by $(x + 3)$

(c) $-3x^3 + 50x - 8$ by $(x - 4)$

Solution:

$$\begin{array}{r}
 x^2 - 2x + 5 \\
 x + 2 \overline{) x^3 + 0x^2 + x + 10} \\
 \underline{x^3 + 2x^2} \\
 -2x^2 + x + 10 \\
 \underline{-2x^2 - 4x} \\
 5x + 10 \\
 \underline{5x + 10} \\
 0
 \end{array}$$

Answer is $x^2 - 2x + 5$

$$\begin{array}{r}
 2x^2 - 6x + 1 \\
 x + 3 \overline{) 2x^3 + 0x^2 - 17x + 3} \\
 \underline{2x^3 + 6x^2} \\
 -6x^2 - 17x + 3 \\
 \underline{-6x^2 - 18x} \\
 x + 3 \\
 \underline{x + 3} \\
 0
 \end{array}$$

Answer is $2x^2 - 6x + 1$

$$\begin{array}{r}
 -3x^2 - 12x + 2 \\
 x - 4 \overline{) -3x^3 + 0x^2 + 50x - 8} \\
 \underline{-3x^3 + 12x^2} \\
 -12x^2 + 50x \\
 \underline{-12x^2 + 48x} \\
 2x - 8 \\
 \underline{2x - 8} \\
 0
 \end{array}$$

(c)

Answer is $-3x^2 - 12x + 2$

© Pearson Education Ltd 2008

Solutionbank C2

Edexcel Modular Mathematics for AS and A-Level

Algebra and functions

Exercise C, Question 2

Question:

Divide:

(a) $x^3 + x^2 - 36$ by $(x - 3)$

(b) $2x^3 + 9x^2 + 25$ by $(x + 5)$

(c) $-3x^3 + 11x^2 - 20$ by $(x - 2)$

Solution:

$$\begin{array}{r}
 x^2 + 4x + 12 \\
 x - 3 \overline{) x^3 + x^2 + 0x - 36} \\
 \underline{x^3 - 3x^2} \\
 4x^2 + 0x \\
 \underline{4x^2 - 12x} \\
 12x - 36 \\
 \underline{12x - 36} \\
 0
 \end{array}$$

Answer is $x^2 + 4x + 12$

$$\begin{array}{r}
 2x^2 - x + 5 \\
 x + 5 \overline{) 2x^3 + 9x^2 + 0x + 25} \\
 \underline{2x^3 + 10x^2} \\
 -x^2 + 0x \\
 \underline{-x^2 - 5x} \\
 5x + 25 \\
 \underline{5x + 25} \\
 0
 \end{array}$$

Answer is $2x^2 - x + 5$

$$\begin{array}{r}
 -3x^2 + 5x + 10 \\
 x - 2 \overline{) -3x^3 + 11x^2 + 0x - 20} \\
 \underline{-3x^3 + 6x^2} \\
 5x^2 + 0x \\
 \underline{5x^2 - 10x} \\
 10x - 20 \\
 \underline{10x - 20} \\
 0
 \end{array}$$

Answer is $-3x^2 + 5x + 10$

© Pearson Education Ltd 2008

Solutionbank C2

Edexcel Modular Mathematics for AS and A-Level

Algebra and functions

Exercise C, Question 3

Question:

Divide:

(a) $x^3 + 2x^2 - 5x - 10$ by $(x + 2)$

(b) $2x^3 - 6x^2 + 7x - 21$ by $(x - 3)$

(c) $-3x^3 + 21x^2 - 4x + 28$ by $(x - 7)$

Solution:

$$\begin{array}{r}
 x^2 - 5 \\
 x + 2 \overline{) x^3 + 2x^2 - 5x - 10} \\
 \underline{x^3 + 2x^2} \\
 0 \\
 \underline{- 5x - 10} \\
 0
 \end{array}$$

(a)

Answer is $x^2 - 5$

$$\begin{array}{r}
 2x^2 + 7 \\
 x - 3 \overline{) 2x^3 - 6x^2 + 7x - 21} \\
 \underline{2x^3 - 6x^2} \\
 0 + 7x - 21 \\
 \underline{7x - 21} \\
 0
 \end{array}$$

(b)

Answer is $2x^2 + 7$

$$\begin{array}{r}
 -3x^2 - 4 \\
 x - 7 \overline{) -3x^3 + 21x^2 - 4x + 28} \\
 \underline{-3x^3 + 21x^2} \\
 0 \\
 \underline{- 4x + 28} \\
 0
 \end{array}$$

(c)

Answer is $-3x^2 - 4$

Solutionbank C2

Edexcel Modular Mathematics for AS and A-Level

Algebra and functions

Exercise C, Question 4

Question:

Find the remainder when:

(a) $x^3 + 4x^2 - 3x + 2$ is divided by $(x + 5)$

(b) $3x^3 - 20x^2 + 10x + 5$ is divided by $(x - 6)$

(c) $-2x^3 + 3x^2 + 12x + 20$ is divided by $(x - 4)$

Solution:

$$\begin{array}{r}
 x^2 - x + 2 \\
 x + 5 \overline{) x^3 + 4x^2 - 3x + 2} \\
 \underline{x^3 + 5x^2} \\
 -x^2 - 3x \\
 \underline{-x^2 - 5x} \\
 2x + 2 \\
 \underline{2x + 10} \\
 -8
 \end{array}$$

The remainder is -8 .

$$\begin{array}{r}
 3x^2 - 2x - 2 \\
 x - 6 \overline{) 3x^3 - 20x^2 + 10x + 5} \\
 \underline{3x^3 - 18x^2} \\
 -2x^2 + 10x \\
 \underline{-2x^2 + 12x} \\
 -2x + 5 \\
 \underline{-2x + 12} \\
 -7
 \end{array}$$

The remainder is -7 .

$$\begin{array}{r}
 2x^2 - 5x 8 \\
 x - 4 2x^3 + 3x^2 + 12x + 20 \\
 2x^3 + 8x^2 \\
 5x^2 + 12x \\
 5x^2 + 20x \\
 8x + 20 \\
 8x + 32 \\
 - 12
 \end{array}$$

The remainder is -12 .

© Pearson Education Ltd 2008

Solutionbank C2

Edexcel Modular Mathematics for AS and A-Level

Algebra and functions

Exercise C, Question 5

Question:

Show that when $3x^3 - 2x^2 + 4$ is divided by $(x - 1)$ the remainder is 5.

Solution:

$$\begin{array}{r}
 3x^2 + x + 1 \\
 x - 1 \overline{) 3x^3 - 2x^2 + 0x + 4} \\
 \underline{3x^3 - 3x^2} \\
 x^2 + 0x \\
 \underline{x^2 - x} \\
 x + 4 \\
 \underline{x - 1} \\
 5
 \end{array}$$

So the remainder is 5.

© Pearson Education Ltd 2008

Solutionbank C2

Edexcel Modular Mathematics for AS and A-Level

Algebra and functions

Exercise C, Question 6

Question:

Show that when $3x^4 - 8x^3 + 10x^2 - 3x - 25$ is divided by $(x + 1)$ the remainder is -1 .

Solution:

$$\begin{array}{r}
 3x^3 - 11x^2 + 21x - 24 \\
 x + 1 \overline{) 3x^4 - 8x^3 + 10x^2 - 3x - 25} \\
 \underline{3x^4 + 3x^3} \\
 -11x^3 + 10x^2 \\
 \underline{-11x^3 - 11x^2} \\
 21x^2 - 3x \\
 \underline{21x^2 + 21x} \\
 -24x - 25 \\
 \underline{-24x - 24} \\
 -1
 \end{array}$$

So the remainder is -1 .

© Pearson Education Ltd 2008

Solutionbank C2

Edexcel Modular Mathematics for AS and A-Level

Algebra and functions

Exercise C, Question 7

Question:

Show that $(x + 4)$ is the factor of $5x^3 - 73x + 28$.

Solution:

$$\begin{array}{r}
 5x^2 - 20x + 7 \\
 x + 4 \overline{) 5x^3 + 0x^2 - 73x + 28} \\
 \underline{5x^3 + 20x^2} \\
 -20x^2 - 73x \\
 \underline{-20x^2 - 80x} \\
 7x + 28 \\
 \underline{7x + 28} \\
 0
 \end{array}$$

The remainder is 0, so $x + 4$ is a factor of $5x^3 - 73x + 28$.

Solutionbank C2

Edexcel Modular Mathematics for AS and A-Level

Algebra and functions

Exercise C, Question 8

Question:

Simplify $\frac{3x^3 - 8x - 8}{x - 2}$.

Solution:

$$\begin{array}{r}
 x - 2 \overline{) \begin{array}{r} 3x^2 + 6x + 4 \\ 3x^3 + 0x^2 - 8x - 8 \\ \hline 3x^3 - 6x^2 \\ \hline 6x^2 - 8x \\ 6x^2 - 12x \\ \hline 4x - 8 \\ 4x - 8 \\ \hline 0 \end{array} \\
 \end{array}$$

So $\frac{3x^3 - 8x - 8}{x - 2} = 3x^2 + 6x + 4$.

Solutionbank C2

Edexcel Modular Mathematics for AS and A-Level

Algebra and functions

Exercise C, Question 9

Question:

Divide $x^3 - 1$ by $(x - 1)$.

Solution:

$$\begin{array}{r}
 x^2 + x + 1 \\
 x - 1 \overline{) x^3 + 0x^2 + 0x - 1} \\
 \underline{x^3 - x^2} \\
 x^2 + 0x \\
 \underline{ x^2 - x} \\
 x - 1 \\
 \underline{ x - 1} \\
 0
 \end{array}$$

Answer is $x^2 + x + 1$.

© Pearson Education Ltd 2008

Solutionbank C2

Edexcel Modular Mathematics for AS and A-Level

Algebra and functions

Exercise C, Question 10

Question:

Divide $x^4 - 16$ by $(x + 2)$.

Solution:

$$\begin{array}{r}
 x^3 - 2x^2 + 4x - 8 \\
 x + 2 \overline{) x^4 + 0x^3 + 0x^2 + 0x - 16} \\
 \underline{x^4 + 2x^3} \\
 - 2x^3 + 0x^2 \\
 \underline{- 2x^3 - 4x^2} \\
 4x^2 + 0x \\
 \underline{4x^2 + 8x} \\
 - 8x - 16 \\
 \underline{- 8x - 16} \\
 0
 \end{array}$$

Answer is $x^3 - 2x^2 + 4x - 8$.

© Pearson Education Ltd 2008

Solutionbank C2

Edexcel Modular Mathematics for AS and A-Level

Algebra and functions

Exercise D, Question 1

Question:

Use the factor theorem to show:

- (a) $(x - 1)$ is a factor of $4x^3 - 3x^2 - 1$
- (b) $(x + 3)$ is a factor of $5x^4 - 45x^2 - 6x - 18$
- (c) $(x - 4)$ is a factor of $-3x^3 + 13x^2 - 6x + 8$

Solution:

(a) $f(x) = 4x^3 - 3x^2 - 1$
 $f(1) = 4(1)^3 - 3(1)^2 - 1 = 4 - 3 - 1 = 0$
So $(x - 1)$ is a factor of $4x^3 - 3x^2 - 1$

(b) $f(x) = 5x^4 - 45x^2 - 6x - 18$
 $f(-3) = 5(-3)^4 - 45(-3)^2 - 6(-3) - 18$
 $f(-3) = 5(81) - 45(9) + 18 - 18 = 405 - 405 = 0$
So $(x + 3)$ is a factor of $5x^4 - 45x^2 - 6x - 18$

(c) $f(x) = -3x^3 + 13x^2 - 6x + 8$
 $f(4) = -3(4)^3 + 13(4)^2 - 6(4) + 8$
 $f(4) = -192 + 208 - 24 + 8 = 0$
So $(x - 4)$ is a factor of $-3x^3 + 13x^2 - 6x + 8$

Solutionbank C2

Edexcel Modular Mathematics for AS and A-Level

Algebra and functions

Exercise D, Question 2

Question:

Show that $(x - 1)$ is a factor of $x^3 + 6x^2 + 5x - 12$ and hence factorise the expression completely.

Solution:

$$f(x) = x^3 + 6x^2 + 5x - 12$$

$$f(1) = (1)^3 + 6(1)^2 + 5(1) - 12 = 1 + 6 + 5 - 12 = 0$$

So $(x - 1)$ is a factor of $x^3 + 6x^2 + 5x - 12$

$$\begin{array}{r}
 x^2 + 7x + 12 \\
 x - 1 \overline{) x^3 + 6x^2 + 5x - 12} \\
 \underline{x^3 - x^2} \\
 7x^2 + 5x \\
 \underline{7x^2 - 7x} \\
 12x - 12 \\
 \underline{12x - 12} \\
 0
 \end{array}$$

$$\text{Now } x^2 + 7x + 12 = (x + 3)(x + 4)$$

$$\text{So } x^3 + 6x^2 + 5x - 12 = (x - 1)(x + 3)(x + 4)$$

Solutionbank C2

Edexcel Modular Mathematics for AS and A-Level

Algebra and functions

Exercise D, Question 3

Question:

Show that $(x + 1)$ is a factor of $x^3 + 3x^2 - 33x - 35$ and hence factorise the expression completely.

Solution:

$$f(x) = x^3 + 3x^2 - 33x - 35$$

$$f(-1) = (-1)^3 + 3(-1)^2 - 33(-1) - 35 = -1 + 3 + 33 - 35 = 0$$

So $(x + 1)$ is a factor of $x^3 + 3x^2 - 33x - 35$

$$\begin{array}{r}
 x^2 + 2x - 35 \\
 x + 1 \overline{) x^3 + 3x^2 - 33x - 35} \\
 \underline{x^3 + x^2} \\
 2x^2 - 33x \\
 \underline{2x^2 + x} \\
 -35x - 35 \\
 \underline{-35x - 35} \\
 0
 \end{array}$$

$$\text{Now } x^2 + 2x - 35 = (x + 7)(x - 5)$$

$$\text{So } x^3 + 3x^2 - 33x - 35 = (x + 1)(x + 7)(x - 5)$$

Solutionbank C2

Edexcel Modular Mathematics for AS and A-Level

Algebra and functions

Exercise D, Question 4

Question:

Show that $(x - 5)$ is a factor of $x^3 - 7x^2 + 2x + 40$ and hence factorise the expression completely.

Solution:

$$f(x) = x^3 - 7x^2 + 2x + 40$$

$$f(5) = (5)^3 - 7(5)^2 + 2(5) + 40$$

$$f(5) = 125 - 175 + 10 + 40 = 0$$

So $(x - 5)$ is a factor of $x^3 - 7x^2 + 2x + 40$

$$\begin{array}{r}
 x^2 - 2x - 8 \\
 x - 5 \overline{) x^3 - 7x^2 + 2x + 40} \\
 \underline{x^3 - 5x^2} \\
 -2x^2 + 2x \\
 \underline{-2x^2 + 10x} \\
 8x + 40 \\
 \underline{-8x + 40} \\
 0
 \end{array}$$

Now $x^2 - 2x - 8 = (x - 4)(x + 2)$

So $x^3 - 7x^2 + 2x + 40 = (x - 5)(x - 4)(x + 2)$.

Solutionbank C2

Edexcel Modular Mathematics for AS and A-Level

Algebra and functions

Exercise D, Question 5

Question:

Show that $(x - 2)$ is a factor of $2x^3 + 3x^2 - 18x + 8$ and hence factorise the expression completely.

Solution:

$$f(x) = 2x^3 + 3x^2 - 18x + 8$$

$$f(2) = 2(2)^3 + 3(2)^2 - 18(2) + 8 = 16 + 12 - 36 + 8 = 0$$

So $(x - 2)$ is a factor of $2x^3 + 3x^2 - 18x + 8$

$$\begin{array}{r}
 2x^2 + 7x - 4 \\
 x - 2 \overline{) 2x^3 + 3x^2 - 18x + 8} \\
 \underline{2x^3 - 4x^2} \\
 7x^2 - 18x \\
 \underline{7x^2 - 14x} \\
 -4x + 8 \\
 \underline{-4x + 8} \\
 0
 \end{array}$$

$$\text{Now } 2x^2 + 7x - 4 = (2x - 1)(x + 4)$$

$$\text{So } 2x^3 + 3x^2 - 18x + 8 = (x - 2)(2x - 1)(x + 4)$$

Solutionbank C2

Edexcel Modular Mathematics for AS and A-Level

Algebra and functions

Exercise D, Question 6

Question:

Each of these expressions has a factor $(x \pm p)$. Find a value of p and hence factorise the expression completely.

(a) $x^3 - 10x^2 + 19x + 30$

(b) $x^3 + x^2 - 4x - 4$

(c) $x^3 - 4x^2 - 11x + 30$

Solution:

(a) $f(x) = x^3 - 10x^2 + 19x + 30$

$$f(-1) = (-1)^3 - 10(-1)^2 + 19(-1) + 30 = -1 - 10 - 19 + 30 = 0$$

So $(x + 1)$ is a factor.

$$\begin{array}{r}
 x^2 - 11x + 30 \\
 x + 1 \overline{) x^3 - 10x^2 + 19x + 30} \\
 \underline{x^3 + + + } \\
 -11x^2 + 19x \\
 \underline{-11x^2 - 11x} \\
 30x + 30 \\
 \underline{30x + 30} \\
 0
 \end{array}$$

Now $x^2 - 11x + 30 = (x - 5)(x - 6)$

So $x^3 - 10x^2 + 19x + 30 = (x + 1)(x - 5)(x - 6)$.

(b) $f(x) = x^3 + x^2 - 4x - 4$

$$f(-1) = (-1)^3 + (-1)^2 - 4(-1) - 4 = -1 + 1 + 4 - 4 = 0$$

So $(x + 1)$ is a factor.

$$\begin{array}{r}
 x^2 - 4 \\
 x + 1 \overline{) x^3 + x^2 - 4x - 4} \\
 \underline{x^3 + x^2} \\
 0 - 4x - 4 \\
 \underline{-4x - 4} \\
 0
 \end{array}$$

Now $x^2 - 4 = (x - 2)(x + 2)$

So $x^3 + x^2 - 4x - 4 = (x + 1)(x - 2)(x + 2)$

(c) $f(x) = x^3 - 4x^2 - 11x + 30$

$$f(2) = (2)^3 - 4(2)^2 - 11(2) + 30 = 8 - 16 - 22 + 30 = 0$$

So $(x - 2)$ is a factor.

$$\begin{array}{r}
 x^2 - 2x - 15 \\
 x - 2 \overline{) x^3 - 4x^2 - 11x + 30} \\
 \underline{x^3 - 2x^2} \\
 - 2x^2 - 11x \\
 \underline{- 2x^2 + 4x} \\
 - 15x + 30 \\
 \underline{- 15x + 30} \\
 0
 \end{array}$$

Now $x^2 - 2x - 15 = (x + 3)(x - 5)$

So $x^3 - 4x^2 - 11x + 30 = (x - 2)(x + 3)(x - 5)$.

© Pearson Education Ltd 2008

Solutionbank C2

Edexcel Modular Mathematics for AS and A-Level

Algebra and functions

Exercise D, Question 7

Question:

Factorise:

(a) $2x^3 + 5x^2 - 4x - 3$

(b) $2x^3 - 17x^2 + 38x - 15$

(c) $3x^3 + 8x^2 + 3x - 2$

(d) $6x^3 + 11x^2 - 3x - 2$

(e) $4x^3 - 12x^2 - 7x + 30$

Solution:

(a) $f(x) = 2x^3 + 5x^2 - 4x - 3$

$f(1) = 2(1)^3 + 5(1)^2 - 4(1) - 3 = 2 + 5 - 4 - 3 = 0$

So $(x - 1)$ is a factor.

$$\begin{array}{r}
 2x^2 + 7x + 3 \\
 x - 1 \overline{) 2x^3 + 5x^2 - 4x - 3} \\
 \underline{2x^3 - 2x^2} \\
 7x^2 - 4x \\
 \underline{7x^2 - 7x} \\
 3x - 3 \\
 \underline{3x - 3} \\
 0
 \end{array}$$

Now $2x^2 + 7x + 3 = (2x + 1)(x + 3)$

So $2x^3 + 5x^2 - 4x - 3 = (x - 1)(2x + 1)(x + 3)$.

(b) $f(x) = 2x^3 - 17x^2 + 38x - 15$

$f(3) = 2(3)^3 - 17(3)^2 + 38(3) - 15 = 54 - 153 + 114 - 15 = 0$

So $(x - 3)$ is a factor.

$$\begin{array}{r}
 2x^2 - 11x + 5 \\
 x - 3 \overline{) 2x^3 - 17x^2 + 38x - 15} \\
 \underline{2x^3 - 6x^2} \\
 -11x^2 + 38x \\
 \underline{-11x^2 + 33x} \\
 5x - 15 \\
 \underline{5x - 15} \\
 0
 \end{array}$$

Now $2x^2 - 11x + 5 = (2x - 1)(x - 5)$

So $2x^3 - 17x^2 + 38x - 15 = (x - 3)(2x - 1)(x - 5)$.

$$(c) f(x) = 3x^3 + 8x^2 + 3x - 2$$

$$f(-1) = 3(-1)^3 + 8(-1)^2 + 3(-1) - 2 = -3 + 8 - 3 - 2 = 0$$

So $(x + 1)$ is a factor.

$$\begin{array}{r} 3x^2 + 5x - 2 \\ x + 1 \overline{) 3x^3 + 8x^2 + 3x - 2} \\ \underline{3x^3 + 3x^2} \\ 5x^2 + 3x \\ \underline{5x^2 + 5x} \\ -2x - 2 \\ \underline{-2x - 2} \\ 0 \end{array}$$

$$\text{Now } 3x^2 + 5x - 2 = (3x - 1)(x + 2)$$

$$\text{So } 3x^3 + 8x^2 + 3x - 2 = (x + 1)(3x - 1)(x + 2).$$

$$(d) f(x) = 6x^3 + 11x^2 - 3x - 2$$

$$f(-2) = 6(-2)^3 + 11(-2)^2 - 3(-2) - 2 = -48 + 44 + 6 - 2 = 0$$

So $(x + 2)$ is a factor.

$$\begin{array}{r} 6x^2 - x - 1 \\ x + 2 \overline{) 6x^3 + 11x^2 - 3x - 2} \\ \underline{6x^3 + 12x^2} \\ -x^2 - 3x \\ \underline{-x^2 - 2x} \\ -x - 2 \\ \underline{-x - 2} \\ 0 \end{array}$$

$$\text{Now } 6x^2 - x - 1 = (3x + 1)(2x - 1)$$

$$\text{So } 6x^3 + 11x^2 - 3x - 2 = (x + 2)(3x + 1)(2x - 1).$$

$$(e) f(x) = 4x^3 - 12x^2 - 7x + 30$$

$$f(2) = 4(2)^3 - 12(2)^2 - 7(2) + 30 = 32 - 48 - 14 + 30 = 0$$

So $(x - 2)$ is a factor.

$$\begin{array}{r} 4x^2 - 4x - 15 \\ x - 2 \overline{) 4x^3 - 12x^2 - 7x + 30} \\ \underline{4x^3 - 8x^2} \\ -4x^2 - 7x \\ \underline{-4x^2 + 8x} \\ -15x + 30 \\ \underline{-15x + 30} \\ 0 \end{array}$$

$$\text{Now } 4x^2 - 4x - 15 = (2x + 3)(2x - 5)$$

$$\text{So } 4x^3 - 12x^2 - 7x + 30 = (x - 2)(2x + 3)(2x - 5).$$

Solutionbank C2

Edexcel Modular Mathematics for AS and A-Level

Algebra and functions

Exercise D, Question 8

Question:

Given that $(x - 1)$ is a factor of $5x^3 - 9x^2 + 2x + a$ find the value of a .

Solution:

$$f(x) = 5x^3 - 9x^2 + 2x + a$$

$$f(1) = 0$$

$$\text{So } 5(1)^3 - 9(1)^2 + 2(1) + a = 0$$

$$5 - 9 + 2 + a = 0$$

$$a = 2$$

© Pearson Education Ltd 2008

Solutionbank C2

Edexcel Modular Mathematics for AS and A-Level

Algebra and functions

Exercise D, Question 9

Question:

Given that $(x + 3)$ is a factor of $6x^3 - bx^2 + 18$ find the value of b .

Solution:

$$f(x) = 6x^3 - bx^2 + 18$$

$$f(-3) = 0$$

$$\text{So } 6(-3)^3 - b(-3)^2 + 18 = 0$$

$$-162 - 9b + 18 = 0$$

$$9b = -144$$

$$b = -16$$

© Pearson Education Ltd 2008

Solutionbank C2

Edexcel Modular Mathematics for AS and A-Level

Algebra and functions

Exercise D, Question 10

Question:

Given that $(x - 1)$ and $(x + 1)$ are factors of $px^3 + qx^2 - 3x - 7$ find the value of p and q .

Solution:

$$f(x) = px^3 + qx^2 - 3x - 7$$

$$\textcircled{1} \quad f(1) = 0$$

$$p(1)^3 + q(1)^2 - 3(1) - 7 = 0$$

$$p + q - 3 - 7 = 0$$

$$p + q = 10$$

$$\textcircled{2} \quad f(-1) = 0$$

$$p(-1)^3 + q(-1)^2 - 3(-1) - 7 = 0$$

$$-p + q + 3 - 7 = 0$$

$$-p + q = 4$$

Solve simultaneously:

$$p + q = 10$$

$$-p + q = 4$$

$$2q = 14$$

$$q = 7$$

$$p + q = 10, \text{ so } p = 3.$$

Answer is $p = 3, q = 7$.

Solutionbank C2

Edexcel Modular Mathematics for AS and A-Level

Algebra and functions

Exercise E, Question 1

Question:

Find the remainder when:

- (a) $4x^3 - 5x^2 + 7x + 1$ is divided by $(x - 2)$
- (b) $2x^5 - 32x^3 + x - 10$ is divided by $(x - 4)$
- (c) $-2x^3 + 6x^2 + 5x - 3$ is divided by $(x + 1)$
- (d) $7x^3 + 6x^2 - 45x + 1$ is divided by $(x + 3)$
- (e) $4x^4 - 4x^2 + 8x - 1$ is divided by $(2x - 1)$
- (f) $243x^4 - 27x^3 - 3x + 7$ is divided by $(3x - 1)$
- (g) $64x^3 + 32x^2 + 16x + 9$ is divided by $(4x + 1)$
- (h) $81x^3 - 81x^2 + 9x + 6$ is divided by $(3x - 2)$
- (i) $243x^6 - 780x^2 + 6$ is divided by $(3x + 4)$
- (j) $125x^4 + 5x^3 - 9x$ is divided by $(5x + 3)$

Solution:

$$\begin{aligned} \text{(a) } f(x) &= 4x^3 - 5x^2 + 7x + 1 \\ f(2) &= 4(2)^3 - 5(2)^2 + 7(2) + 1 \\ f(2) &= 32 - 20 + 14 + 1 = 27 \\ \text{Remainder is } &27. \end{aligned}$$

$$\begin{aligned} \text{(b) } f(x) &= 2x^5 - 32x^3 + x - 10 \\ f(4) &= 2(4)^5 - 32(4)^3 + (4) - 10 \\ f(4) &= 2048 - 2048 + 4 - 10 = -6 \\ \text{Remainder is } &-6. \end{aligned}$$

$$\begin{aligned} \text{(c) } f(x) &= -2x^3 + 6x^2 + 5x - 3 \\ f(-1) &= -2(-1)^3 + 6(-1)^2 + 5(-1) - 3 \\ f(-1) &= 2 + 6 - 5 - 3 = 0 \\ \text{Remainder is } &0. \end{aligned}$$

$$\begin{aligned} \text{(d) } f(x) &= 7x^3 + 6x^2 - 45x + 1 \\ f(-3) &= 7(-3)^3 + 6(-3)^2 - 45(-3) + 1 \\ f(-3) &= -189 + 54 + 135 + 1 = 1 \\ \text{Remainder is } &1. \end{aligned}$$

$$\begin{aligned} \text{(e) } f(x) &= 4x^4 - 4x^2 + 8x - 1 \\ f\left(\frac{1}{2}\right) &= 4\left(\frac{1}{2}\right)^4 - 4\left(\frac{1}{2}\right)^2 + 8\left(\frac{1}{2}\right) - 1 \end{aligned}$$

$$f\left(\frac{1}{2}\right) = \frac{1}{4} - 1 + 4 - 1 = 2\frac{1}{4}$$

Remainder is $2\frac{1}{4}$.

$$(f) f(x) = 243x^4 - 27x^3 - 3x + 7$$

$$f\left(\frac{1}{3}\right) = 243\left(\frac{1}{3}\right)^4 - 27\left(\frac{1}{3}\right)^3 - 3\left(\frac{1}{3}\right) + 7$$

$$f\left(\frac{1}{3}\right) = 3 - 1 - 1 + 7 = 8$$

Remainder is 8.

$$(g) f(x) = 64x^3 + 32x^2 - 16x + 9$$

$$f\left(-\frac{1}{4}\right) = 64\left(-\frac{1}{4}\right)^3 + 32\left(-\frac{1}{4}\right)^2 - 16\left(-\frac{1}{4}\right) + 9$$

$$f\left(-\frac{1}{4}\right) = -1 + 2 + 4 + 9 = 14$$

Remainder is 14.

$$(h) f(x) = 81x^3 - 81x^2 + 9x + 6$$

$$f\left(\frac{2}{3}\right) = 81\left(\frac{2}{3}\right)^3 - 81\left(\frac{2}{3}\right)^2 + 9\left(\frac{2}{3}\right) + 6$$

$$f\left(\frac{2}{3}\right) = 24 - 36 + 6 + 6 = 0$$

Remainder is 0.

$$(i) f(x) = 243x^6 - 780x^2 + 6$$

$$f\left(-\frac{4}{3}\right) = 243\left(-\frac{4}{3}\right)^6 - 780\left(-\frac{4}{3}\right)^2 + 6$$

$$f\left(-\frac{4}{3}\right) = \frac{4096}{3} - \frac{4160}{3} + 6 = -\frac{64}{3} + 6 = -21\frac{1}{3} + 6 = -15\frac{1}{3}$$

Remainder is $-15\frac{1}{3}$.

$$(j) f(x) = 125x^4 + 5x^3 - 9x$$

$$f\left(-\frac{3}{5}\right) = 125\left(-\frac{3}{5}\right)^4 + 5\left(-\frac{3}{5}\right)^3 - 9\left(-\frac{3}{5}\right)$$

$$f\left(-\frac{3}{5}\right) = \frac{405}{25} - \frac{27}{25} + \frac{27}{5} = \frac{378}{25} + \frac{135}{25} = \frac{513}{25} = 20\frac{13}{25}$$

Remainder is $20\frac{13}{25}$ ($= 20.52$).

Solutionbank C2

Edexcel Modular Mathematics for AS and A-Level

Algebra and functions

Exercise E, Question 2

Question:

When $2x^3 - 3x^2 - 2x + a$ is divided by $(x - 1)$ the remainder is -4 . Find the value of a .

Solution:

$$f(x) = 2x^3 - 3x^2 - 2x + a$$

$$f(1) = -4$$

$$\text{So } 2(1)^3 - 3(1)^2 - 2(1) + a = -4$$

$$2 - 3 - 2 + a = -4$$

$$a = -1$$

© Pearson Education Ltd 2008

Solutionbank C2

Edexcel Modular Mathematics for AS and A-Level

Algebra and functions

Exercise E, Question 3

Question:

When $-3x^3 + 4x^2 + bx + 6$ is divided by $(x + 2)$ the remainder is 10. Find the value of b .

Solution:

$$f(x) = -3x^3 + 4x^2 + bx + 6$$

$$f(-2) = 10$$

$$\text{So } -3(-2)^3 + 4(-2)^2 + b(-2) + 6 = 10$$

$$24 + 16 - 2b + 6 = 10$$

$$2b = 36$$

$$b = 18$$

© Pearson Education Ltd 2008

Solutionbank C2

Edexcel Modular Mathematics for AS and A-Level

Algebra and functions

Exercise E, Question 4

Question:

When $16x^3 - 32x^2 + cx - 8$ is divided by $(2x - 1)$ the remainder is 1. Find the value of c .

Solution:

$$f(x) = 16x^3 - 32x^2 + cx - 8$$

$$f\left(\frac{1}{2}\right) = 1$$

$$\text{So } 16\left(\frac{1}{2}\right)^3 - 32\left(\frac{1}{2}\right)^2 + c\left(\frac{1}{2}\right) - 8 = 1$$

$$2 - 8 + \frac{1}{2}c - 8 = 1$$

$$\frac{1}{2}c = 15$$

$$c = 30$$

© Pearson Education Ltd 2008

Solutionbank C2

Edexcel Modular Mathematics for AS and A-Level

Algebra and functions

Exercise E, Question 5

Question:

Show that $(x - 3)$ is a factor of $x^6 - 36x^3 + 243$.

Solution:

$$f(x) = x^6 - 36x^3 + 243$$

$$f(3) = (3)^6 - 36(3)^3 + 243$$

$$f(3) = 729 - 972 + 243 = 0$$

Remainder is 0, so $(x - 3)$ is a factor.

Solutionbank C2

Edexcel Modular Mathematics for AS and A-Level

Algebra and functions

Exercise E, Question 6

Question:

Show that $(2x - 1)$ is a factor of $2x^3 + 17x^2 + 31x - 20$.

Solution:

$$f(x) = 2x^3 + 17x^2 + 31x - 20$$

$$f\left(\frac{1}{2}\right) = 2\left(\frac{1}{2}\right)^3 + 17\left(\frac{1}{2}\right)^2 + 31\left(\frac{1}{2}\right) - 20$$

$$f\left(\frac{1}{2}\right) = \frac{1}{4} + \frac{17}{4} + \frac{31}{2} - 20 = \frac{1 + 17 + 62 - 80}{4} = 0$$

Remainder is 0, so $(2x - 1)$ is a factor.

© Pearson Education Ltd 2008

Solutionbank C2

Edexcel Modular Mathematics for AS and A-Level

Algebra and functions

Exercise E, Question 7

Question:

$f(x) = x^2 + 3x + q$. Given $f(2) = 3$, find $f(-2)$.

Solution:

$$f(x) = x^2 + 3x + q$$

$$\text{Given } f(2) = 3.$$

$$\text{So } (2)^2 + 3(2) + q = 3$$

$$4 + 6 + q = 3$$

$$q = -7$$

$$f(x) = x^2 + 3x - 7$$

$$f(-2) = (-2)^2 + 3(-2) - 7$$

$$f(-2) = 4 - 6 - 7 = -9$$

Answer is -9 .

Solutionbank C2

Edexcel Modular Mathematics for AS and A-Level

Algebra and functions

Exercise E, Question 8

Question:

$g(x) = x^3 + ax^2 + 3x + 6$. Given $g(-1) = 2$, find the remainder when $g(x)$ is divided by $(3x - 2)$.

Solution:

$$g(x) = x^3 + ax^2 + 3x + 6$$

$$\text{Given } g(-1) = 2.$$

$$\text{So } (-1)^3 + a(-1)^2 + 3(-1) + 6 = 2$$

$$-1 + a - 3 + 6 = 2$$

$$a = 0$$

$$g(x) = x^3 + 3x + 6$$

$$g\left(\frac{2}{3}\right) = \left(\frac{2}{3}\right)^3 + 3\left(\frac{2}{3}\right) + 6$$

$$g\left(\frac{2}{3}\right) = \frac{8}{27} + 2 + 6 = 8\frac{8}{27}$$

Answer is $8\frac{8}{27}$.

Solutionbank C2

Edexcel Modular Mathematics for AS and A-Level

Algebra and functions

Exercise E, Question 9

Question:

The expression $2x^3 - x^2 + ax + b$ gives a remainder 14 when divided by $(x - 2)$ and a remainder -86 when divided by $(x + 3)$. Find the value of a and b .

Solution:

$$f(x) = 2x^3 - x^2 + ax + b$$

$$\textcircled{1} \quad f(2) = 14$$

$$\text{So } 2(2)^3 - (2)^2 + a(2) + b = 14$$

$$16 - 4 + 2a + b = 14$$

$$2a + b = 2$$

$$\textcircled{2} \quad f(-3) = -86$$

$$\text{So } 2(-3)^3 - (-3)^2 + a(-3) + b = -86$$

$$-54 - 9 - 3a + b = -86$$

$$-3a + b = -23$$

Solve simultaneously:

$$2a + b = 2$$

$$-3a + b = -23$$

$$5a = 25$$

$$a = 5$$

$$2a + b = 2$$

Substitute $a = 5$:

$$2(5) + b = 2$$

$$10 + b = 2$$

$$b = -8$$

Check $a = 5, b = -8$ by substitution:

$$-3a + b = -3(5) + (-8) = -15 - 8 = -23 \quad \checkmark$$

Answer is $a = 5, b = -8$.

Solutionbank C2

Edexcel Modular Mathematics for AS and A-Level

Algebra and functions

Exercise E, Question 10

Question:

The expression $3x^3 + 2x^2 - px + q$ is divisible by $(x - 1)$ but leaves a remainder of 10 when divided by $(x + 1)$. Find the value of a and b .

Solution:

$$f(x) = 3x^3 + 2x^2 - px + q$$

$$\textcircled{1} \quad f(1) = 0$$

$$\text{So } 3(1)^3 + 2(1)^2 - p(1) + q = 0$$

$$3 + 2 - p + q = 0$$

$$-p + q = -5$$

$$\textcircled{2} \quad f(-1) = 10$$

$$\text{So } 3(-1)^3 + 2(-1)^2 - p(-1) + q = 0$$

$$-3 + 2 + p + q = 10$$

$$p + q = 11$$

Solve simultaneously:

$$-p + q = -5$$

$$p + q = 11$$

$$2q = 6$$

$$q = 3$$

Substitute $q = 3$:

$$p + q = 11$$

$$p + 3 = 11$$

$$p = 8$$

$$\text{Check: } -p + q = -8 + 3 = -5 \checkmark$$

Answer is $p = 8, q = 3$.

Solutionbank C2

Edexcel Modular Mathematics for AS and A-Level

Algebra and functions

Exercise F, Question 1

Question:

Simplify these fractions as far as possible:

$$(a) \frac{3x^4 - 21x}{3x}$$

$$(b) \frac{x^2 - 2x - 24}{x^2 - 7x + 6}$$

$$(c) \frac{2x^2 + 7x - 4}{2x^2 + 9x + 4}$$

Solution:

$$(a) \frac{3x^4 - 21x}{3x} = \frac{3x^4}{3x} - \frac{21x}{3x} = x^3 - 7$$

$$(b) \frac{x^2 - 2x - 24}{x^2 - 7x + 6}$$

$$= \frac{(x-6)(x+4)}{(x-6)(x-1)}$$

$$= \frac{x+4}{x-1}$$

$$(c) \frac{2x^2 + 7x - 4}{2x^2 + 9x + 4}$$

$$= \frac{(2x-1)(x+4)}{(2x+1)(x+4)}$$

$$= \frac{2x-1}{2x+1}$$

Solutionbank C2

Edexcel Modular Mathematics for AS and A-Level

Algebra and functions

Exercise F, Question 2

Question:

Divide $3x^3 + 12x^2 + 5x + 20$ by $(x + 4)$.

Solution:

$$\begin{array}{r}
 3x^2 + 5 \\
 x + 4 \overline{) 3x^3 + 12x^2 + 5x + 20} \\
 \underline{3x^3 + 12x^2} \\
 0 + 5x + 20 \\
 \underline{5x + 20} \\
 0
 \end{array}$$

Answer is $3x^2 + 5$.

© Pearson Education Ltd 2008

Solutionbank C2

Edexcel Modular Mathematics for AS and A-Level

Algebra and functions
Exercise F, Question 3

Question:

Simplify $\frac{2x^3 + 3x + 5}{x + 1}$.

Solution:

$$\begin{array}{r}
 x + 1 \overline{) \begin{array}{r} 2x^2 - 2x \quad + 5 \\ 2x^3 + 0x^2 + 3x + 5 \\ \hline 2x^3 + 2x^2 \\ \hline - 2x^2 + 3x \\ - 2x^2 - 2x \\ 5x + 5 \\ 5x + 5 \\ \hline 0 \end{array} \\
 \end{array}$$

So $\frac{2x^3 + 3x + 5}{x + 1} = 2x^2 - 2x + 5$.

© Pearson Education Ltd 2008

Solutionbank C2

Edexcel Modular Mathematics for AS and A-Level

Algebra and functions

Exercise F, Question 4

Question:

Show that $(x - 3)$ is a factor of $2x^3 - 2x^2 - 17x + 15$. Hence express $2x^3 - 2x^2 - 17x + 15$ in the form $(x - 3) \left(Ax^2 + Bx + C \right)$, where the values A , B and C are to be found.

Solution:

$$f(x) = 2x^3 - 2x^2 - 17x + 15$$

$$f(3) = 2(3)^3 - 2(3)^2 - 17(3) + 15$$

$$f(3) = 54 - 18 - 51 + 15 = 0$$

So $(x - 3)$ is a factor.

$$\begin{array}{r}
 2x^2 + 4x - 5 \\
 x - 3 \overline{) 2x^3 - 2x^2 - 17x + 15} \\
 \underline{2x^3 - 6x^2} \\
 4x^2 - 17x \\
 \underline{4x^2 - 12x} \\
 -5x + 15 \\
 \underline{-5x + 15} \\
 0
 \end{array}$$

$$\text{So } 2x^3 - 2x^2 - 17x + 15 = (x - 3)(2x^2 + 4x - 5).$$

$$\text{So } A = 2, B = 4, C = -5$$

Solutionbank C2

Edexcel Modular Mathematics for AS and A-Level

Algebra and functions

Exercise F, Question 5

Question:

Show that $(x - 2)$ is a factor of $x^3 + 4x^2 - 3x - 18$. Hence express $x^3 + 4x^2 - 3x - 18$ in the form $(x - 2)(px + q)^2$, where the values p and q are to be found.

Solution:

$$f(x) = x^3 + 4x^2 - 3x - 18$$

$$f(2) = (2)^3 + 4(2)^2 - 3(2) - 18$$

$$f(2) = 8 + 16 - 6 - 18 = 0$$

So $(x - 2)$ is a factor.

$$\begin{array}{r}
 x^2 + 6x + 9 \\
 x - 2 \overline{) x^3 + 4x^2 - 3x - 18} \\
 \underline{x^3 - 2x^2} \\
 6x^2 - 3x \\
 \underline{6x^2 - 12x} \\
 9x - 18 \\
 \underline{9x - 18} \\
 0
 \end{array}$$

$$\text{Now } x^2 + 6x + 9 = (x + 3)(x + 3) = (x + 3)^2$$

$$\text{So } x^3 + 4x^2 - 3x - 18 = (x - 2)(x + 3)^2.$$

$$\text{So } p = 1, q = 3.$$

Solutionbank C2

Edexcel Modular Mathematics for AS and A-Level

Algebra and functions

Exercise F, Question 6

Question:

Factorise completely $2x^3 + 3x^2 - 18x + 8$.

Solution:

$$f(x) = 2x^3 + 3x^2 - 18x + 8$$

$$f(2) = 2(2)^3 + 3(2)^2 - 18(2) + 8$$

$$f(2) = 16 + 12 - 36 + 8 = 0$$

So $(x - 2)$ is a factor.

$$\begin{array}{r}
 2x^2 + 7x - 4 \\
 x - 2 \overline{) 2x^3 + 3x^2 - 18x + 8} \\
 \underline{2x^3 - 4x^2} \\
 7x^2 - 18x \\
 \underline{7x^2 - 14x} \\
 -4x + 8 \\
 \underline{-4x + 8} \\
 0
 \end{array}$$

$$\text{Now } 2x^2 + 7x - 4 = (2x - 1)(x + 4)$$

$$\text{So } 2x^3 + 3x^2 - 18x + 8 = (x - 2)(2x - 1)(x + 4).$$

Solutionbank C2

Edexcel Modular Mathematics for AS and A-Level

Algebra and functions

Exercise F, Question 7

Question:

Find the value of k if $(x - 2)$ is a factor of $x^3 - 3x^2 + kx - 10$.

Solution:

$$f(x) = x^3 - 3x^2 + kx - 10$$

$$f(2) = 0$$

$$\text{So } (2)^3 - 3(2)^2 + k(2) - 10 = 0$$

$$8 - 12 + 2k - 10 = 0$$

$$2k = 14$$

$$k = 7$$

© Pearson Education Ltd 2008

Solutionbank C2

Edexcel Modular Mathematics for AS and A-Level

Algebra and functions

Exercise F, Question 8

Question:

Find the remainder when $16x^5 - 20x^4 + 8$ is divided by $(2x - 1)$.

Solution:

$$f(x) = 16x^5 - 20x^4 + 8$$

$$f\left(\frac{1}{2}\right) = 16\left(\frac{1}{2}\right)^5 - 20\left(\frac{1}{2}\right)^4 + 8$$

$$f\left(\frac{1}{2}\right) = \frac{1}{2} - \frac{5}{4} + 8 = 7\frac{1}{4}$$

© Pearson Education Ltd 2008

Solutionbank C2

Edexcel Modular Mathematics for AS and A-Level

Algebra and functions

Exercise F, Question 9

Question:

$f(x) = 2x^2 + px + q$. Given that $f(-3) = 0$, and $f(4) = 2$:

(a) find the value of p and q

(b) factorise $f(x)$

Solution:

(a) $f(x) = 2x^2 + px + q$

① $f(-3) = 0$

So $2(-3)^2 + p(-3) + q = 0$

$18 - 3p + q = 0$

$3p - q = 18$

② $f(4) = 2$

So $2(4)^2 + p(4) + q = 2$

$4p + q = -11$

Solving simultaneously:

$$3p - q = 18$$

$$4p + q = -11$$

$$7p = 7$$

$$p = 1$$

Substitute $p = 1$ into $4p + q = -11$:

$$4(1) + q = -11$$

$$q = -15$$

Check: $3p - q = 3(1) - (-15) = 3 + 15 = 18$ ✓

So $p = 1, q = -15$

(b) $f(x) = 2x^2 + x - 15 = (2x - 5)(x + 3)$

Solutionbank C2

Edexcel Modular Mathematics for AS and A-Level

Algebra and functions

Exercise F, Question 10

Question:

$h(x) = x^3 + 4x^2 + rx + s$. Given $h(-1) = 0$, and $h(2) = 30$:

(a) find the value of r and s

(b) find the remainder when $h(x)$ is divided by $(3x - 1)$

Solution:

(a) $h(x) = x^3 + 4x^2 + rx + s$

① $h(-1) = 0$

So $(-1)^3 + 4(-1)^2 + r(-1) + s = 0$

$$-1 + 4 - r + s = 0$$

$$-r + s = -3$$

② $h(2) = 30$

So $(2)^3 + 4(2)^2 + r(2) + s = 30$

$$8 + 16 + 2r + s = 30$$

$$2r + s = 6$$

Solving simultaneously:

$$2r + s = 6$$

$$-r + s = -3$$

$$3r = 9$$

$$r = 3$$

Substitute $r = 3$ into $-r + s = -3$:

$$-3 + s = -3$$

$$s = 0$$

Check: $2r + s = 2(3) + (0) = 6$ ✓

So $r = 3$, $s = 0$

(b) $h(x) = x^3 + 4x^2 + 3x$

$$h\left(\frac{1}{3}\right) = \left(\frac{1}{3}\right)^3 + 4\left(\frac{1}{3}\right)^2 + 3\left(\frac{1}{3}\right)$$

$$h\left(\frac{1}{3}\right) = \frac{1}{27} + \frac{4}{9} + 1 = 1\frac{13}{27}$$

Remainder is $1\frac{13}{27}$.

Solutionbank C2

Edexcel Modular Mathematics for AS and A-Level

Algebra and functions

Exercise F, Question 11

Question:

$$g(x) = 2x^3 + 9x^2 - 6x - 5.$$

(a) Factorise $g(x)$

(b) Solve $g(x) = 0$

Solution:

(a) $g(x) = 2x^3 + 9x^2 - 6x - 5$

$$g(1) = 2(1)^3 + 9(1)^2 - 6(1) - 5$$

$$g(1) = 2 + 9 - 6 - 5 = 0$$

So $(x - 1)$ is a factor.

$$\begin{array}{r}
 2x^2 + 11x + 5 \\
 x - 1 \overline{) 2x^3 + 9x^2 - 6x - 5} \\
 \underline{2x^3 - 2x^2} \\
 11x^2 - 6x \\
 \underline{11x^2 - 11x} \\
 5x - 5 \\
 \underline{5x - 5} \\
 0
 \end{array}$$

Now $2x^2 + 11x + 5 = (2x + 1)(x + 5)$

So $g(x) = (x - 1)(2x + 1)(x + 5)$

(b) $g(x) = 0$

$$(x - 1)(2x + 1)(x + 5) = 0$$

So $x = 1, x = -\frac{1}{2}, x = -5.$

Solutionbank C2

Edexcel Modular Mathematics for AS and A-Level

Algebra and functions

Exercise F, Question 12

Question:

The remainder obtained when $x^3 - 5x^2 + px + 6$ is divided by $(x + 2)$ is equal to the remainder obtained when the same expression is divided by $(x - 3)$.
Find the value of p .

Solution:

$$g(x) = x^3 - 5x^2 + px + 6$$

$$\textcircled{1} g(-2) = R$$

$$\text{So } (-2)^3 - 5(-2)^2 + p(-2) + 6 = R$$

$$-8 - 20 - 2p + 6 = R$$

$$-2p - 22 = R$$

$$\textcircled{2} g(3) = R$$

$$\text{So } (3)^3 - 5(3)^2 + p(3) + 6 = R$$

$$27 - 45 + 3p + 6 = R$$

$$3p - 12 = R$$

Solving simultaneously:

$$-2p - 22 = 3p - 12$$

$$-5p = 10$$

$$p = -2$$

Solutionbank C2

Edexcel Modular Mathematics for AS and A-Level

Algebra and functions

Exercise F, Question 13

Question:

The remainder obtained when $x^3 + dx^2 - 5x + 6$ is divided by $(x - 1)$ is twice the remainder obtained when the same expression is divided by $(x + 1)$.
Find the value of d .

Solution:

$$f(x) = x^3 + dx^2 - 5x + 6$$

$$\text{Let } f(-1) = R$$

$$\text{So } (-1)^3 + d(-1)^2 - 5(-1) + 6 = R$$

$$-1 + d + 5 + 6 = R$$

$$d + 10 = R$$

$$\text{Now } f(1) = 2R$$

$$\text{So } (1)^3 + d(1)^2 - 5(1) + 6 = 2R$$

$$1 + d - 5 + 6 = 2R$$

$$d + 2 = 2R$$

Solving simultaneously:

$$d + 2 = 2(d + 10)$$

$$d + 2 = 2d + 20$$

$$2 = d + 20$$

$$d = -18$$

Solutionbank C2

Edexcel Modular Mathematics for AS and A-Level

Algebra and functions

Exercise F, Question 14

Question:

(a) Show that $(x - 2)$ is a factor of $f(x) = x^3 + x^2 - 5x - 2$.

(b) Hence, or otherwise, find the exact solutions of the equation $f(x) = 0$.

[E]

Solution:

$$(a) f(x) = x^3 + x^2 - 5x - 2$$

$$f(2) = (2)^3 + (2)^2 - 5(2) - 2$$

$$f(2) = 8 + 4 - 10 - 2 = 0$$

So $(x - 2)$ is a factor.

$$x - 2 \overline{) \begin{array}{r} x^2 + 3x + 1 \\ x^3 + x^2 - 5x - 2 \\ \hline x^3 - 2x^2 \\ \hline 3x^2 - 5x + 1 \\ - 6x + 1 \\ \hline x - 2 \\ \hline x - 2 \\ \hline 0 \end{array}}$$

$$(b) \quad 3x^2 - 5x$$

$$3x^2 - 6x$$

$$x - 2$$

$$x - 2$$

0

$$\text{So } f(x) = (x - 2)(x^2 + 3x + 1)$$

$$\text{Now } f(x) = 0 \text{ when } x = 2$$

$$\text{and } x^2 + 3x + 1 = 0$$

$$\text{i.e. } x = \frac{-3 \pm \sqrt{(3)^2 - 4(1)(1)}}{2(1)} \quad \left(x = \frac{-b \pm \sqrt{b^2 - 4ac}}{2a} \right)$$

$$\Rightarrow x = \frac{-3 \pm \sqrt{5}}{2}$$

$$\text{So } x = 2, x = \frac{-3 + \sqrt{5}}{2}, x = \frac{-3 - \sqrt{5}}{2}$$

Solutionbank C2

Edexcel Modular Mathematics for AS and A-Level

Algebra and functions

Exercise F, Question 15

Question:

Given that -1 is a root of the equation $2x^3 - 5x^2 - 4x + 3$, find the two positive roots.

[E]

Solution:

$$\begin{array}{r}
 2x^2 - 7x + 3 \\
 x + 1 \overline{) 2x^3 - 5x^2 - 4x + 3} \\
 \underline{2x^3 + 2x^2} \\
 -7x^2 - 4x \\
 \underline{-7x^2 - 7x} \\
 3x + 3 \\
 \underline{3x + 3} \\
 0
 \end{array}$$

Now $2x^2 - 7x + 3 = (2x - 1)(x - 3)$

So $2x^3 - 5x^2 - 4x + 3 = (x + 1)(2x - 1)(x - 3)$.

The roots are -1 , $\frac{1}{2}$ and 3 .

The positive roots are $x = \frac{1}{2}$ and $x = 3$.

Solutionbank C2

Edexcel Modular Mathematics for AS and A-Level

The sine and cosine rule

Exercise A, Question 1

Question:

In each of parts (a) to (d), given values refer to the general triangle:

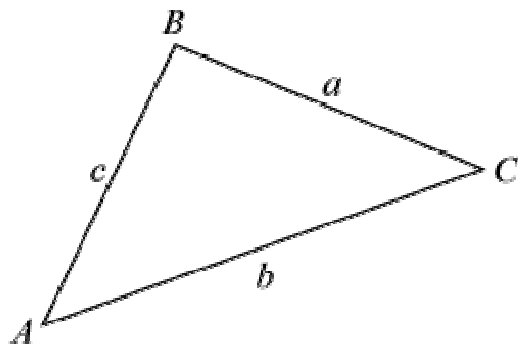

- (a) Given that $a = 8$ cm, $A = 30^\circ$, $B = 72^\circ$, find b .
- (b) Given that $a = 24$ cm, $A = 110^\circ$, $C = 22^\circ$, find c .
- (c) Given that $b = 14.7$ cm, $A = 30^\circ$, $C = 95^\circ$, find a .
- (d) Given that $c = 9.8$ cm, $B = 68.4^\circ$, $C = 83.7^\circ$, find a .

Solution:

(a)

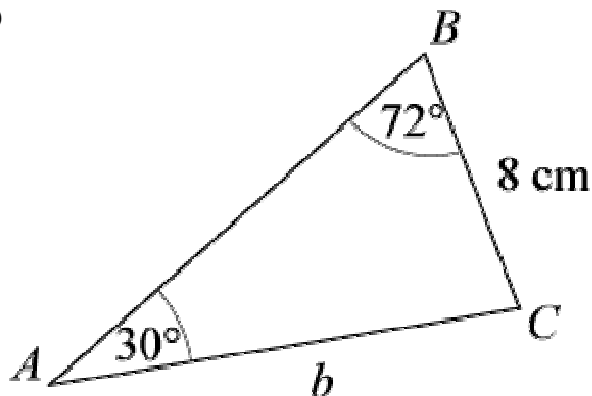

$$\text{Using } \frac{a}{\sin A} = \frac{b}{\sin B}$$

$$\frac{b}{\sin 72^\circ} = \frac{8}{\sin 30^\circ}$$

$$\Rightarrow b = \frac{8 \sin 72^\circ}{\sin 30^\circ} = 15.2 \text{ cm (3 s.f.)}$$

(Check: as $72^\circ > 30^\circ$, $b > 8$ cm.)

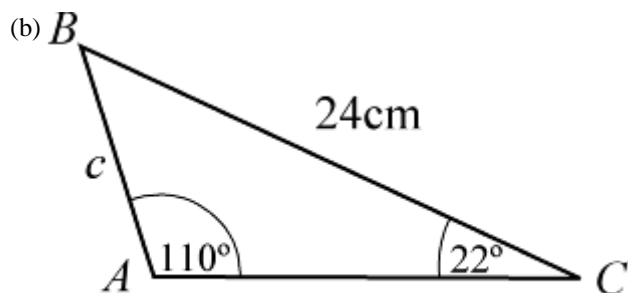

Using $\frac{a}{\sin A} = \frac{c}{\sin C}$

$$\frac{c}{\sin 22^\circ} = \frac{24}{\sin 110^\circ}$$

$$\Rightarrow c = \frac{24 \sin 22^\circ}{\sin 110^\circ} = 9.57 \text{ cm (3 s.f.)}$$

(As $110^\circ > 22^\circ$, $24\text{cm} > c$.)

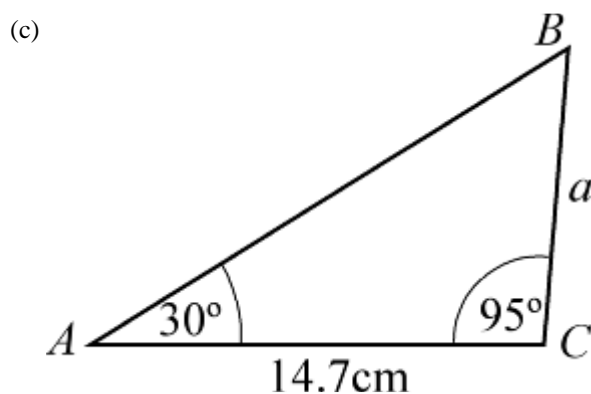

$$\angle ABC = 180^\circ - (30 + 95)^\circ = 55^\circ$$

Using $\frac{a}{\sin A} = \frac{b}{\sin B}$

$$\frac{a}{\sin 30^\circ} = \frac{14.7}{\sin 55^\circ}$$

$$\Rightarrow a = \frac{14.7 \sin 30^\circ}{\sin 55^\circ} = 8.97 \text{ cm (3 s.f.)}$$

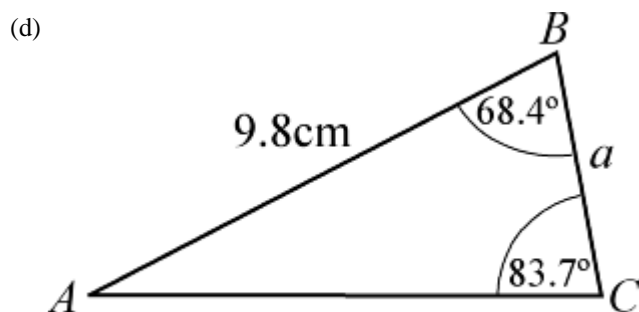

$$\angle BAC = 180^\circ - (68.4 + 83.7)^\circ = 27.9^\circ$$

Using $\frac{a}{\sin A} = \frac{c}{\sin C}$

$$\frac{a}{\sin 27.9^\circ} = \frac{9.8}{\sin 83.7^\circ}$$

$$\Rightarrow a = \frac{9.8 \sin 27.9^\circ}{\sin 83.7^\circ} = 4.61 \text{ cm (3 s.f.)}$$

© Pearson Education Ltd 2008

Solutionbank C2

Edexcel Modular Mathematics for AS and A-Level

The sine and cosine rule

Exercise A, Question 2

Question:

In each of the following triangles calculate the values of x and y .

(a)

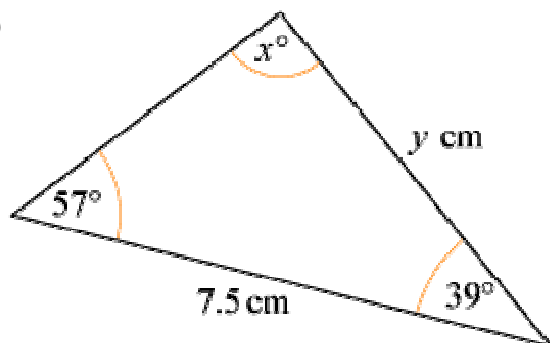

(b)

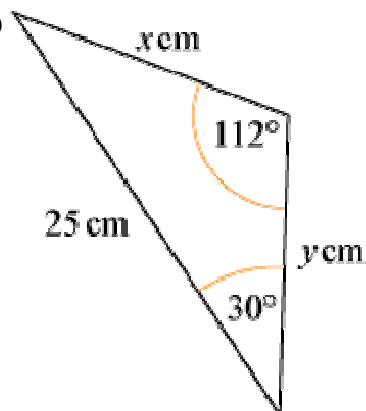

(c)

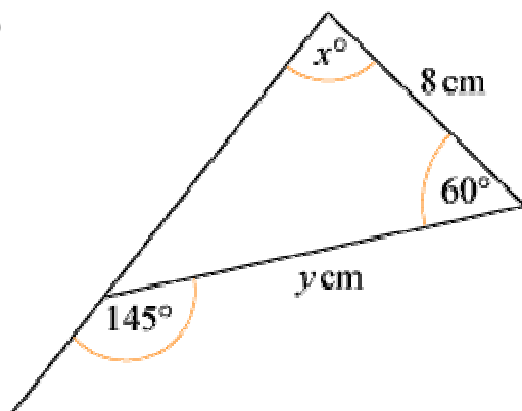

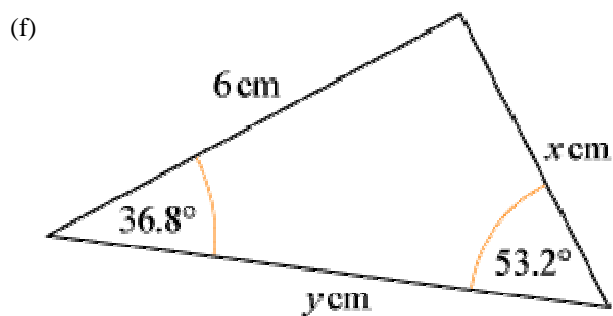
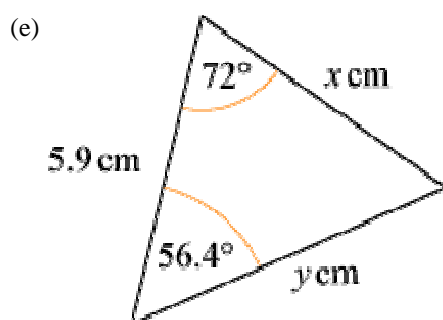
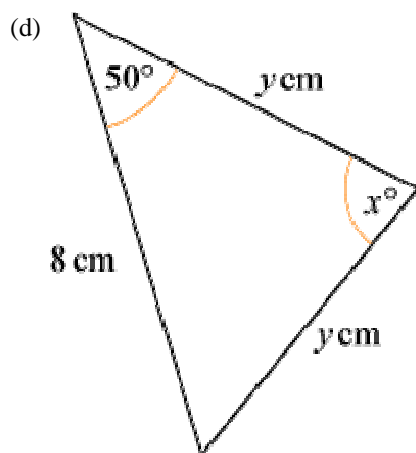

Solution:

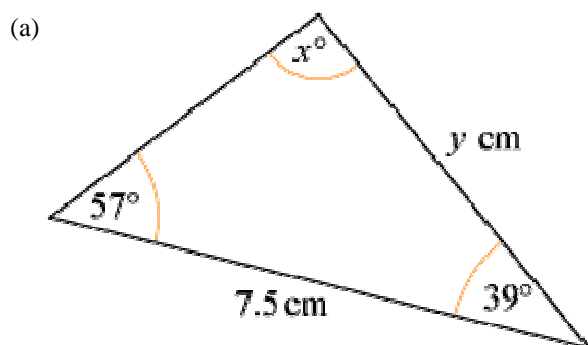

$$x = 180 - (57 + 39) = 84$$

Using $\frac{a}{\sin A} = \frac{b}{\sin B}$

$$\Rightarrow \frac{y}{\sin 57^\circ} = \frac{7.5}{\sin 84^\circ}$$

$$\Rightarrow y = \frac{7.5 \sin 57^\circ}{\sin 84^\circ} = 6.32 \text{ (3 s.f.)}$$

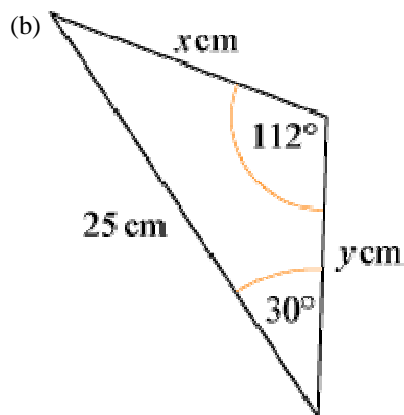

Using $\frac{a}{\sin A} = \frac{c}{\sin C}$

$$\Rightarrow \frac{x}{\sin 30^\circ} = \frac{25}{\sin 112^\circ}$$

$$\Rightarrow x = \frac{25 \sin 30^\circ}{\sin 112^\circ} = 13.5 \text{ (3 s.f.)}$$

$$\angle B = 180^\circ - (112 + 30)^\circ = 38^\circ$$

Using $\frac{b}{\sin B} = \frac{c}{\sin C}$

$$\Rightarrow \frac{y}{\sin 38^\circ} = \frac{25}{\sin 112^\circ}$$

$$\Rightarrow y = \frac{25 \sin 38^\circ}{\sin 112^\circ} = 16.6 \text{ (3 s.f.)}$$

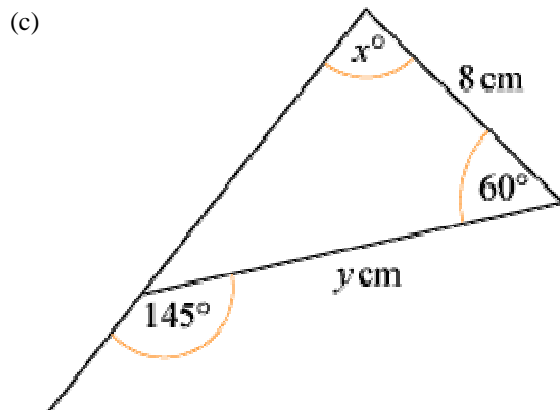

$$x = 180 - (60 + 35) = 85$$

Using $\frac{b}{\sin B} = \frac{a}{\sin A}$

$$\frac{y}{\sin 85^\circ} = \frac{8}{\sin 35^\circ}$$

$$\Rightarrow y = \frac{8 \sin 85^\circ}{\sin 35^\circ} = 13.9 \text{ (3 s.f.)}$$

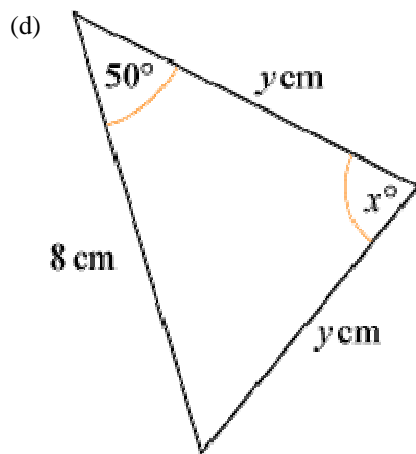

$$x = 180 - (50 + 50) = 80$$

Using $\frac{a}{\sin A} = \frac{c}{\sin C}$

$$\Rightarrow \frac{y}{\sin 50^\circ} = \frac{8}{\sin 80^\circ}$$

$$\Rightarrow y = \frac{8 \sin 50^\circ}{\sin 80^\circ} = 6.22 \text{ (3 s.f.)}$$

(Note: You could use the line of symmetry to split the triangle into two right-angled triangles and use $\cos 50^\circ = \frac{4}{y}$.)

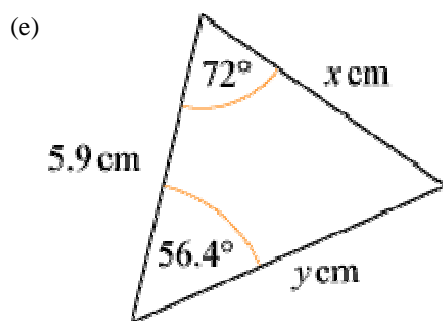

$$\angle C = 180^\circ - (56.4 + 72)^\circ = 51.6^\circ$$

Using $\frac{a}{\sin A} = \frac{c}{\sin C}$

$$\Rightarrow \frac{x}{\sin 56.4^\circ} = \frac{5.9}{\sin 51.6^\circ}$$

$$\Rightarrow x = \frac{5.9 \sin 56.4^\circ}{\sin 51.6^\circ} = 6.27 \text{ (3 s.f.)}$$

Using $\frac{b}{\sin B} = \frac{c}{\sin C}$

$$\Rightarrow \frac{y}{\sin 72^\circ} = \frac{5.9}{\sin 51.6^\circ}$$

$$\Rightarrow y = \frac{5.9 \sin 72^\circ}{\sin 51.6^\circ} = 7.16 \text{ (3 s.f.)}$$

(f)

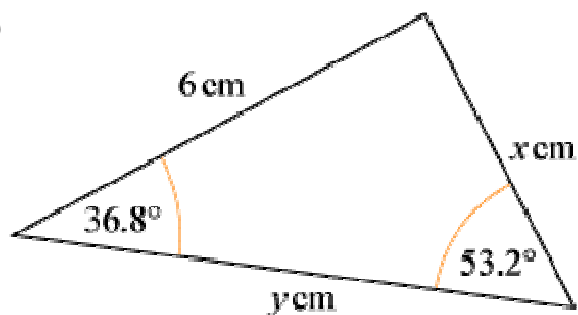

Using $\frac{a}{\sin A} = \frac{c}{\sin C}$

$$\Rightarrow \frac{x}{\sin 36.8^\circ} = \frac{6}{\sin 53.2^\circ}$$

$$\Rightarrow x = \frac{6 \sin 36.8^\circ}{\sin 53.2^\circ} = 4.49 \text{ (3 s.f.)}$$

$$\angle B = 180^\circ - (36.8 + 53.2)^\circ = 90^\circ$$

Using $\frac{b}{\sin B} = \frac{c}{\sin C}$

$$\Rightarrow \frac{6}{\sin 53.2^\circ} = \frac{y}{\sin 90^\circ}$$

$$\Rightarrow y = \frac{6 \sin 90^\circ}{\sin 53.2^\circ} = 7.49 \text{ (3 s.f.)}$$

(Note: The third angle is 90° so you could solve the problem using sine and cosine; the sine rule is not necessary.)

© Pearson Education Ltd 2008

Solutionbank C2

Edexcel Modular Mathematics for AS and A-Level

The sine and cosine rule

Exercise A, Question 3

Question:

In $\triangle PQR$, $QR = \sqrt{3}$ cm, $\angle PQR = 45^\circ$ and $\angle QPR = 60^\circ$. Find (a) PR and (b) PQ .

Solution:

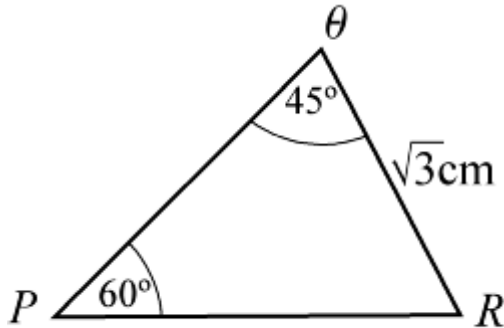

(a) Using $\frac{q}{\sin Q} = \frac{p}{\sin P}$

$$\Rightarrow \frac{PR}{\sin 45^\circ} = \frac{\sqrt{3}}{\sin 60^\circ}$$

$$\Rightarrow PR = \frac{\sqrt{3} \sin 45^\circ}{\sin 60^\circ} = 1.41 \text{ cm (3 s.f.)}$$

(The exact answer is $\sqrt{2}$ cm.)

(b) Using $\frac{r}{\sin R} = \frac{p}{\sin P}$

$$\Rightarrow \frac{PQ}{\sin 75^\circ} = \frac{\sqrt{3}}{\sin 60^\circ} [\text{Angle } R = 180^\circ - (60 + 45)^\circ = 75^\circ]$$

$$\Rightarrow PQ = \frac{\sqrt{3} \sin 75^\circ}{\sin 60^\circ} = 1.93 \text{ cm (3 s.f.)}$$

Solutionbank C2

Edexcel Modular Mathematics for AS and A-Level

The sine and cosine rule

Exercise A, Question 4

Question:

Town B is 6 km, on a bearing of 020° , from town A . Town C is located on a bearing of 055° from town A and on a bearing of 120° from town B . Work out the distance of town C from (a) town A and (b) town B .

Solution:

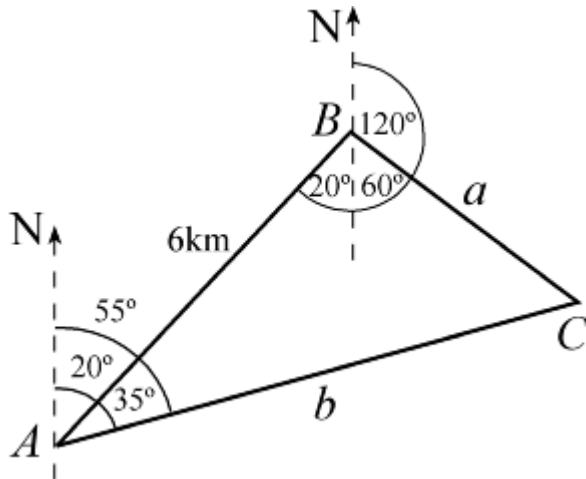

$$\angle BAC = 55^\circ - 20^\circ = 35^\circ$$

$$\angle ABC = 20^\circ \text{ ('Z' angles)} + 60^\circ \text{ (angles on a straight line)} = 80^\circ$$

$$\angle ACB = 180^\circ - (80 + 35)^\circ = 65^\circ$$

(a) Using $\frac{b}{\sin B} = \frac{c}{\sin C}$

$$\Rightarrow \frac{AC}{\sin 80^\circ} = \frac{6}{\sin 65^\circ}$$

$$\Rightarrow AC = \frac{6 \sin 80^\circ}{\sin 65^\circ} = 6.52 \text{ km (3 s.f.)}$$

(b) Using $\frac{a}{\sin A} = \frac{c}{\sin C}$

$$\Rightarrow \frac{BC}{\sin 35^\circ} = \frac{6}{\sin 65^\circ} \Rightarrow BC = \frac{6 \sin 35^\circ}{\sin 65^\circ} = 3.80 \text{ km (3 s.f.)}$$

Solutionbank C2

Edexcel Modular Mathematics for AS and A-Level

The sine and cosine rule

Exercise A, Question 5

Question:

In the diagram $AD = DB = 5$ cm, $\angle ABC = 43^\circ$

and $\angle ACB = 72^\circ$.

Calculate (a) AB and (b) CD .

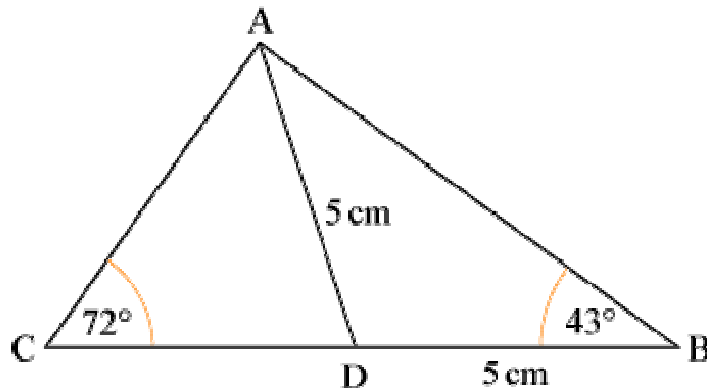

Solution:

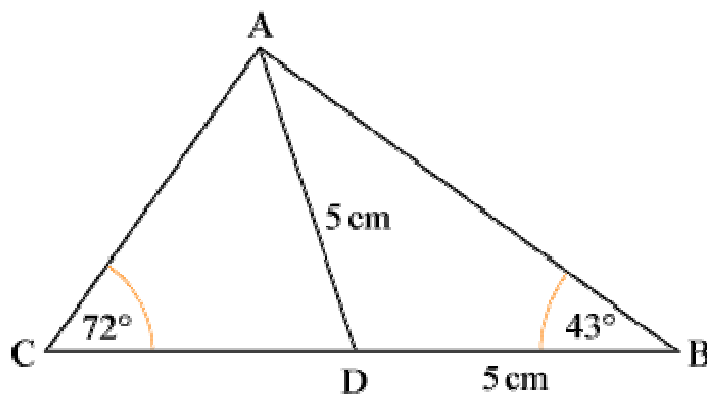

(a) In $\triangle ABD$, $\angle DAB = 43^\circ$ (isosceles \triangle).

So $\angle ADB = 180^\circ - (2 \times 43^\circ) = 94^\circ$

As triangle is isosceles you could work with right-angled triangle, but using sine rule $\frac{d}{\sin D} = \frac{a}{\sin A}$

$$\Rightarrow \frac{AB}{\sin 94^\circ} = \frac{5}{\sin 43^\circ}$$

$$\Rightarrow AB = \frac{5 \sin 94^\circ}{\sin 43^\circ} = 7.31 \text{ cm (3 s.f.)}$$

(b) In $\triangle ADC$, $\angle ADC = 180^\circ - 94^\circ = 86^\circ$ (angles on a straight line).

So $\angle CAD = 180^\circ - (72 + 86)^\circ = 22^\circ$

Using $\frac{a}{\sin A} = \frac{c}{\sin C}$

$$\Rightarrow \frac{CD}{\sin 22^\circ} = \frac{5}{\sin 72^\circ}$$

$$\Rightarrow CD = \frac{5 \sin 22^\circ}{\sin 72^\circ} = 1.97 \text{ cm (3 s.f.)}$$

© Pearson Education Ltd 2008

Solutionbank C2

Edexcel Modular Mathematics for AS and A-Level

The sine and cosine rule

Exercise B, Question 1

Question:

(Note: Give answers to 3 significant figures, unless they are exact.)

In each of the following sets of data for a triangle ABC , find the value of x :

(a) $AB = 6$ cm, $BC = 9$ cm, $\angle BAC = 117^\circ$, $\angle ACB = x^\circ$.

(b) $AC = 11$ cm, $BC = 10$ cm, $\angle ABC = 40^\circ$, $\angle CAB = x^\circ$.

(c) $AB = 6$ cm, $BC = 8$ cm, $\angle BAC = 60^\circ$, $\angle ACB = x^\circ$.

(d) $AB = 8.7$ cm, $AC = 10.8$ cm, $\angle ABC = 28^\circ$, $\angle BAC = x^\circ$.

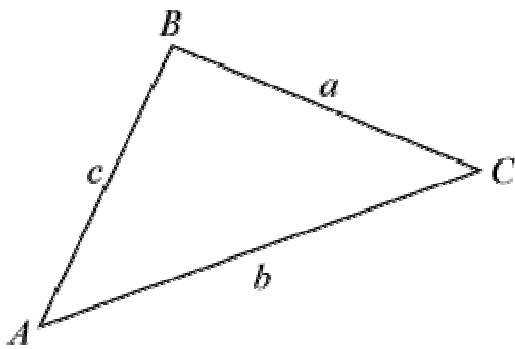

Solution:

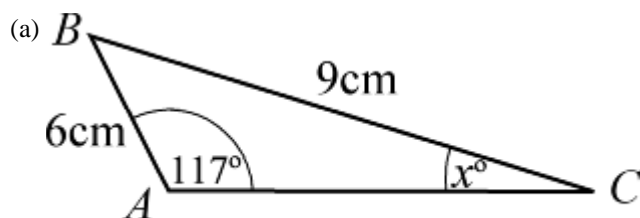

Using $\frac{\sin C}{c} = \frac{\sin A}{a}$

$$\Rightarrow \frac{\sin x^\circ}{6} = \frac{\sin 117^\circ}{9}$$

$$\Rightarrow \sin x^\circ = \frac{6 \sin 117^\circ}{9} (= 0.5940\dots)$$

$$\Rightarrow x^\circ = \sin^{-1} \left(\frac{6 \sin 117^\circ}{9} \right) = 36.4^\circ \text{ (3 s.f.)}$$

$$\Rightarrow x = 36.4$$

(b)

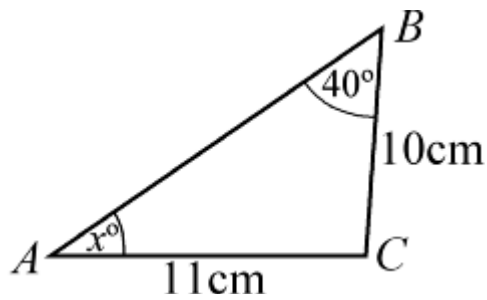

Using $\frac{\sin A}{a} = \frac{\sin B}{b}$

$$\Rightarrow \frac{\sin x^\circ}{10} = \frac{\sin 40^\circ}{11}$$

$$\Rightarrow \sin x^\circ = \frac{10 \sin 40^\circ}{11} (= 0.5843\dots)$$

$$\Rightarrow x^\circ = \sin^{-1} \left(\frac{10 \sin 40^\circ}{11} \right) = 35.8^\circ \text{ (3 s.f.)}$$

$$\Rightarrow x = 35.8$$

(c)

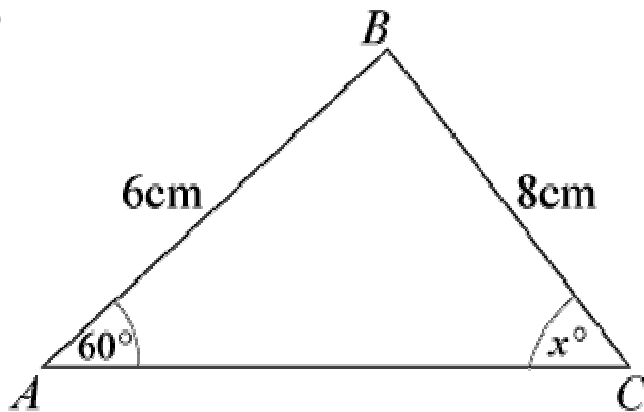

Using $\frac{\sin C}{c} = \frac{\sin A}{a}$

$$\Rightarrow \frac{\sin x^\circ}{6} = \frac{\sin 60^\circ}{8}$$

$$\Rightarrow \sin x^\circ = \frac{6 \sin 60^\circ}{8} (= 0.6495\dots)$$

$$\Rightarrow x^\circ = \sin^{-1} \left(\frac{6 \sin 60^\circ}{8} \right) = 40.5^\circ \text{ (3 s.f.)}$$

$$\Rightarrow x = 40.5$$

(d)

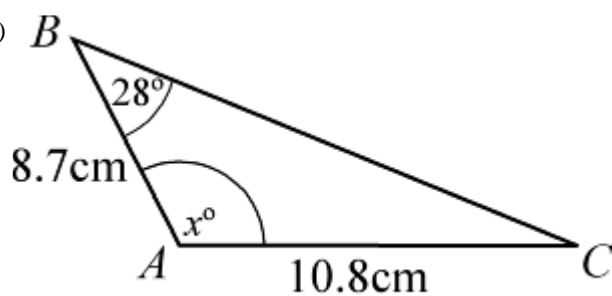

Using $\frac{\sin C}{c} = \frac{\sin B}{b}$

$$\Rightarrow \frac{\sin C^\circ}{8.7} = \frac{\sin 28^\circ}{10.8}$$

$$\Rightarrow \sin C^\circ = \frac{8.7 \sin 28^\circ}{10.8} (= 0.3781\dots)$$

$$\Rightarrow C^\circ = \sin^{-1} \left(\frac{8.7 \sin 28^\circ}{10.8} \right)$$

$$\Rightarrow C = 22.2^\circ \text{ (3 s.f.)}$$

$$\Rightarrow x^\circ = 180^\circ - (28 + 22.2)^\circ = 129.8^\circ = 130^\circ \text{ (3 s.f.)}$$

$$\Rightarrow x = 130$$

© Pearson Education Ltd 2008

Solutionbank C2

Edexcel Modular Mathematics for AS and A-Level

The sine and cosine rule

Exercise B, Question 2

Question:

(Note: Give answers to 3 significant figures, unless they are exact.)

In each of the diagrams shown below, work out the value of x :

(a)

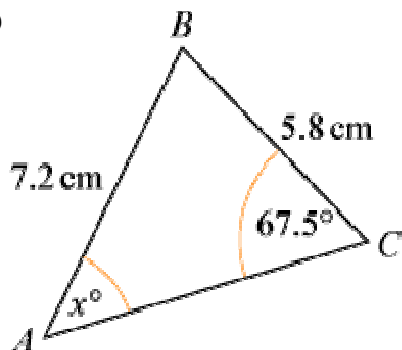

(b)

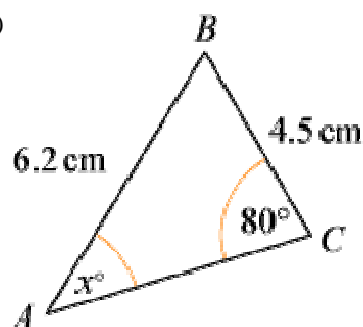

(c)

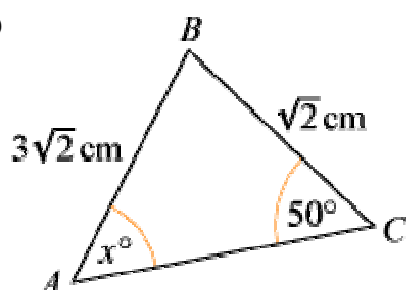

(d)

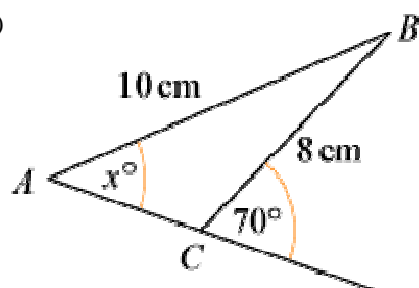

(e)

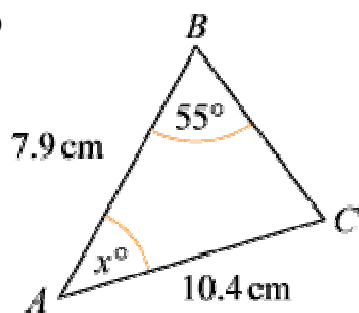

(f)

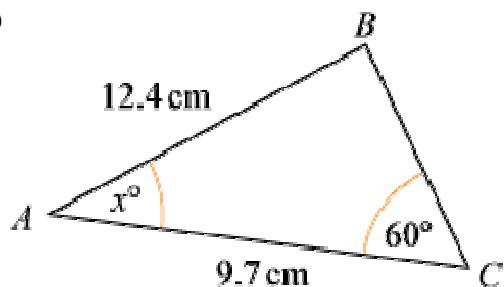
**Solution:**

(a)

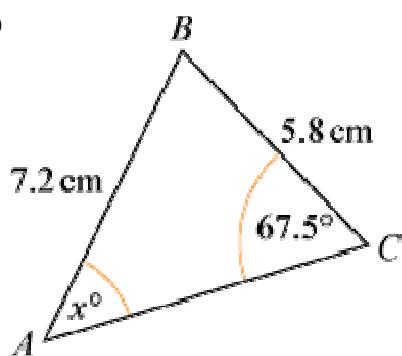
Using $\frac{\sin A}{a} = \frac{\sin C}{c}$

$$\Rightarrow \frac{\sin x^\circ}{5.8} = \frac{\sin 67.5^\circ}{7.2}$$

$$\Rightarrow \sin x^\circ = \frac{5.8 \sin 67.5^\circ}{7.2} (= 0.7442\dots)$$

$$\Rightarrow x^\circ = \sin^{-1} \left(\frac{5.8 \sin 67.5^\circ}{7.2} \right) = 48.09^\circ$$

$$\Rightarrow x = 48.1 \text{ (3 s.f.)}$$

(b)

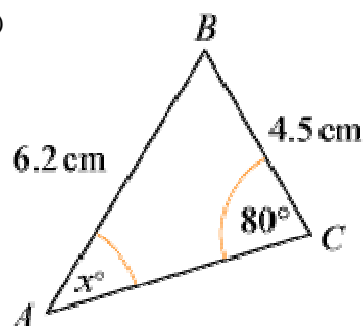

Using $\frac{\sin A}{a} = \frac{\sin C}{c}$

$$\Rightarrow \frac{\sin x^\circ}{4.5} = \frac{\sin 80^\circ}{6.2}$$

$$\Rightarrow \sin x^\circ = \frac{4.5 \sin 80^\circ}{6.2} (= 0.7147\dots)$$

$$\Rightarrow x^\circ = \sin^{-1} \left(\frac{4.5 \sin 80^\circ}{6.2} \right) = 45.63^\circ$$

$$\Rightarrow x = 45.6 \text{ (3 s.f.)}$$

(c)

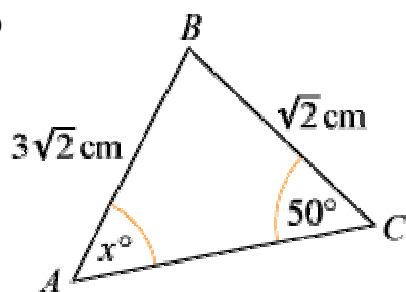

Using $\frac{\sin A}{a} = \frac{\sin C}{c}$

$$\Rightarrow \frac{\sin x^\circ}{\sqrt{2}} = \frac{\sin 50^\circ}{3\sqrt{2}}$$

$$\Rightarrow \sin x^\circ = \frac{\sqrt{2} \sin 50^\circ}{3\sqrt{2}} (= 0.2553 \dots)$$

$$\Rightarrow x^\circ = \sin^{-1} \left(\frac{\sin 50^\circ}{3} \right) = 14.79^\circ$$

$$\Rightarrow x = 14.8 \text{ (3 s.f.)}$$

(d)

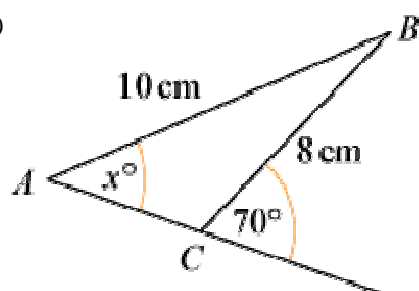

$$\text{Angle } ACB = 180^\circ - 70^\circ = 110^\circ$$

Using $\frac{\sin A}{a} = \frac{\sin C}{c}$

$$\Rightarrow \frac{\sin x^\circ}{8} = \frac{\sin 110^\circ}{10}$$

$$\Rightarrow \sin x^\circ = \frac{8 \sin 110^\circ}{10} (= 0.7517\dots)$$

$$\Rightarrow x^\circ = \sin^{-1} \left(\frac{8 \sin 110^\circ}{10} \right) = 48.74^\circ$$

$$\Rightarrow x = 48.7 \text{ (3 s.f.)}$$

(e)

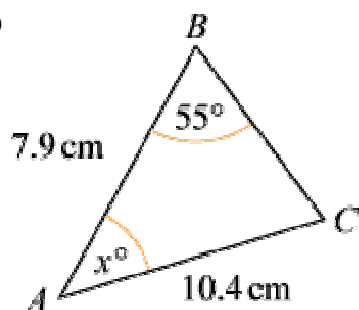

Using $\frac{\sin C}{c} = \frac{\sin B}{b}$

$$\Rightarrow \frac{\sin C}{7.9} = \frac{\sin 55^\circ}{10.4}$$

$$\Rightarrow \sin C = \frac{7.9 \sin 55^\circ}{10.4} (= 0.6222\dots)$$

$$\Rightarrow C = \sin^{-1} \left(\frac{7.9 \sin 55^\circ}{10.4} \right) = 38.48^\circ$$

$$x^\circ = 180^\circ - (55 + C)^\circ$$

$$\Rightarrow x = 86.52 = 86.5 \text{ (3 s.f.)}$$

(f)

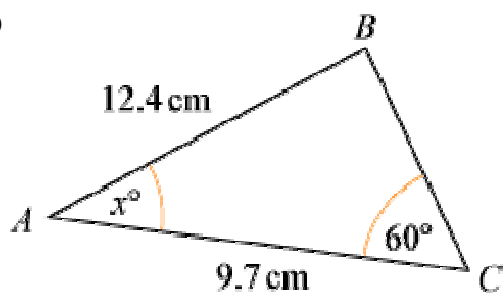

Using $\frac{\sin B}{b} = \frac{\sin C}{c}$

$$\Rightarrow \frac{\sin B}{9.7} = \frac{\sin 60^\circ}{12.4}$$

$$\Rightarrow \sin B = \frac{9.7 \sin 60^\circ}{12.4} (= 0.6774\dots)$$

$$\Rightarrow B = 42.65^\circ$$

$$x^\circ = 180^\circ - (60 + B)^\circ = 77.35^\circ$$

$$\Rightarrow x = 77.4 \text{ (3 s.f.)}$$

© Pearson Education Ltd 2008

Solutionbank C2

Edexcel Modular Mathematics for AS and A-Level

The sine and cosine rule

Exercise B, Question 3

Question:

(Note: Give answers to 3 significant figures, unless they are exact.)

In $\triangle PQR$, $PQ = 15$ cm, $QR = 12$ cm and $\angle PRQ = 75^\circ$. Find the two remaining angles.

Solution:

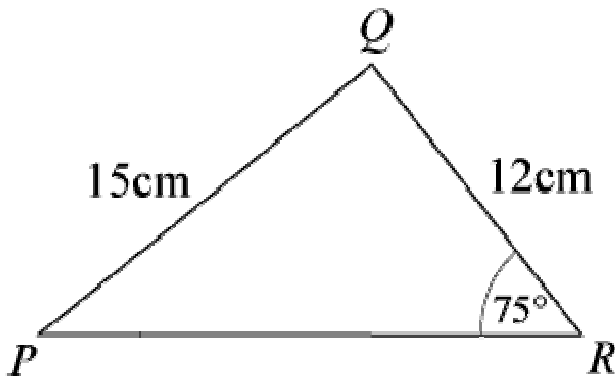

Using $\frac{\sin P}{p} = \frac{\sin R}{r}$

$$\Rightarrow \frac{\sin P}{12} = \frac{\sin 75^\circ}{15}$$

$$\Rightarrow \sin P = \frac{12 \sin 75^\circ}{15} (= 0.7727\dots)$$

$$\Rightarrow P = \sin^{-1} \left(\frac{12 \sin 75^\circ}{15} \right) = 50.60^\circ$$

Angle QPR = 50.6° (3 s.f.)

Angle PQR = $180^\circ - (75 + 50.6)^\circ = 54.4^\circ$ (3 s.f.)

Solutionbank C2

Edexcel Modular Mathematics for AS and A-Level

The sine and cosine rule

Exercise B, Question 4

Question:

(Note: Give answers to 3 significant figures, unless they are exact.)

In each of the following diagrams work out the values of x and y :

(a)

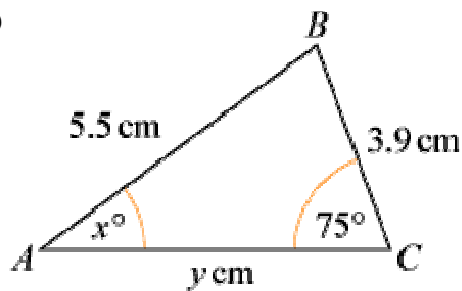

(b)

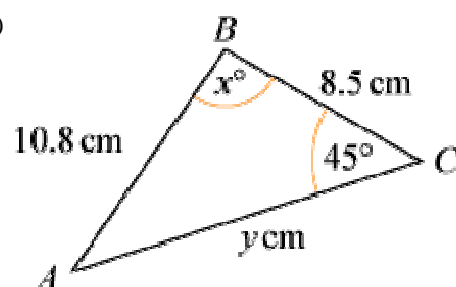

(c)

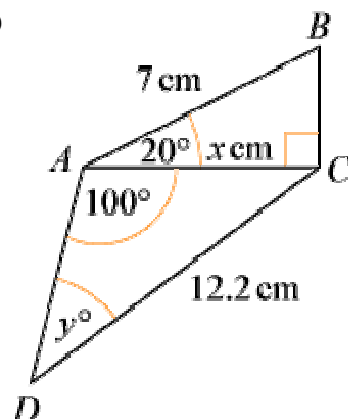

(d)

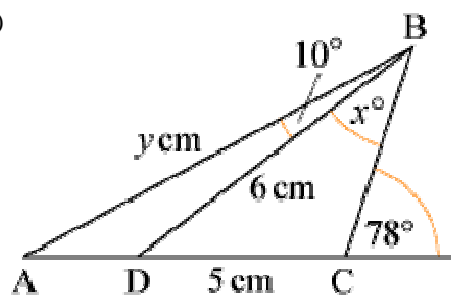

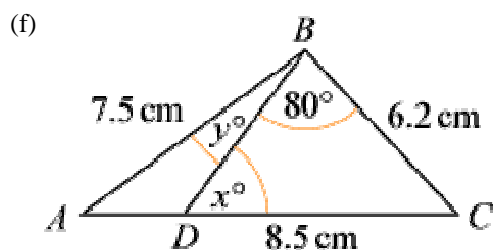
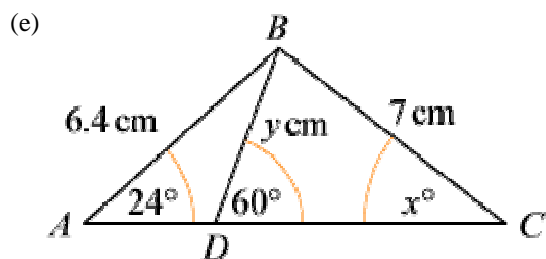

Solution:

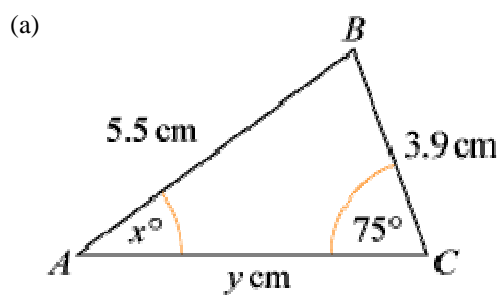

Using $\frac{\sin A}{a} = \frac{\sin C}{c}$

$$\Rightarrow \frac{\sin x^\circ}{3.9} = \frac{\sin 75^\circ}{5.5}$$

$$\Rightarrow \sin x^\circ = \frac{3.9 \sin 75^\circ}{5.5}$$

$$\Rightarrow x^\circ = \sin^{-1} \left(\frac{3.9 \sin 75^\circ}{5.5} \right) = 43.23^\circ$$

$$\Rightarrow x = 43.2 \text{ (3 s.f.)}$$

So $\angle ABC = 180^\circ - (75 + 43.2)^\circ = 61.8^\circ$

Using $\frac{b}{\sin B} = \frac{c}{\sin C}$

$$\Rightarrow \frac{y}{\sin 61.8^\circ} = \frac{5.5}{\sin 75^\circ}$$

$$\Rightarrow y = \frac{5.5 \sin 61.8^\circ}{\sin 75^\circ} = 5.018$$

$$\Rightarrow y = 5.02 \text{ (3 s.f.)}$$

(b)

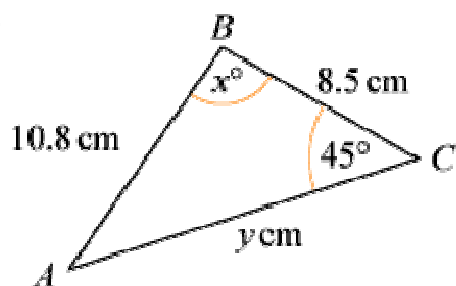

Using $\frac{\sin A}{a} = \frac{\sin C}{c}$

$$\Rightarrow \frac{\sin A}{8.5} = \frac{\sin 45^\circ}{10.8}$$

$$\Rightarrow \sin A = \frac{8.5 \sin 45^\circ}{10.8}$$

$$\Rightarrow A = \sin^{-1} \left(\frac{8.5 \sin 45^\circ}{10.8} \right) = 33.815^\circ$$

$$x^\circ = 180^\circ - (45 + A)^\circ = 101.2^\circ$$

$$\Rightarrow x = 101 \text{ (3 s.f.)}$$

Using $\frac{b}{\sin B} = \frac{c}{\sin C}$

$$\Rightarrow \frac{y}{\sin x^\circ} = \frac{10.8}{\sin 45^\circ}$$

$$\Rightarrow y = \frac{10.8 \sin x^\circ}{\sin 45^\circ} = 14.98$$

$$\Rightarrow y = 15.0 \text{ (3 s.f.)}$$

(c)

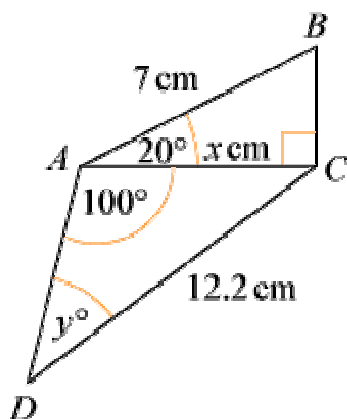

In $\triangle ABC$, $\frac{x}{7} = \cos 20^\circ \Rightarrow x = 7 \cos 20^\circ = 6.578 = 6.58 \text{ (3 s.f.)}$

In $\triangle ADC$, using $\frac{\sin D}{d} = \frac{\sin A}{a}$

$$\Rightarrow \frac{\sin y^\circ}{x} = \frac{\sin 100^\circ}{12.2}$$

$$\Rightarrow \sin y^\circ = \frac{x \sin 100^\circ}{12.2}$$

$$\Rightarrow y^\circ = \sin^{-1} \left(\frac{x \sin 100^\circ}{12.2} \right) = 32.07^\circ$$

$$\Rightarrow y = 32.1 \text{ (3 s.f.)}$$

(d)

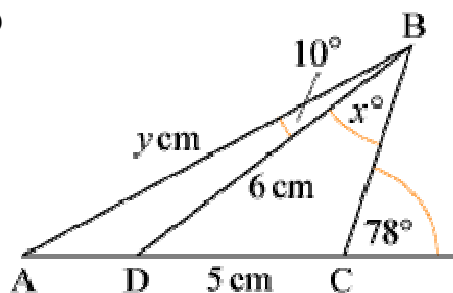

In $\triangle BDC$, $\angle C = 180^\circ - 78^\circ = 102^\circ$

Using $\frac{\sin B}{b} = \frac{\sin C}{c}$

$$\Rightarrow \frac{\sin x^\circ}{5} = \frac{\sin 102^\circ}{6}$$

$$\Rightarrow \sin x^\circ = \frac{5 \sin 102^\circ}{6}$$

$$\Rightarrow x^\circ = \sin^{-1} \left(\frac{5 \sin 102^\circ}{6} \right) = 54.599^\circ$$

$$\Rightarrow x = 54.6 \text{ (3 s.f.)}$$

In $\triangle ABC$, $\angle BAC = 180^\circ - 102^\circ - (10 + x)^\circ = 13.4^\circ$

So $\angle ADB = 180^\circ - 10^\circ - 13.4^\circ = 156.6^\circ$

Using $\frac{d}{\sin D} = \frac{a}{\sin A}$ in $\triangle ABD$

$$\Rightarrow \frac{y}{\sin 156.6^\circ} = \frac{6}{\sin 13.4^\circ}$$

$$\Rightarrow y = \frac{6 \sin 156.6^\circ}{\sin 13.4^\circ} = 10.28 = 10.3 \text{ (3 s.f.)}$$

(e)

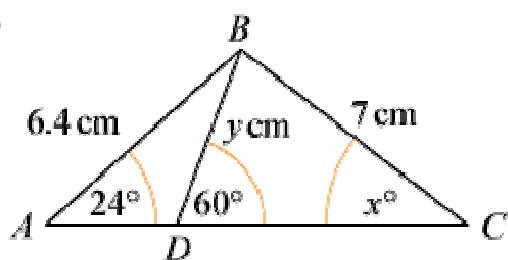

In $\triangle ABC$, using $\frac{\sin C}{c} = \frac{\sin A}{a}$

$$\Rightarrow \frac{\sin x^\circ}{6.4} = \frac{\sin 24^\circ}{7}$$

$$\Rightarrow \sin x^\circ = \frac{6.4 \sin 24^\circ}{7}$$

$$\Rightarrow x^\circ = \sin^{-1} \left(\frac{6.4 \sin 24^\circ}{7} \right) = 21.83^\circ$$

$$\Rightarrow x = 21.8 \text{ (3 s.f.)}$$

In $\triangle ABD$, using $\frac{a}{\sin A} = \frac{d}{\sin D}$

$$\Rightarrow \frac{y}{\sin 24^\circ} = \frac{6.4}{\sin 120^\circ}$$

$$\Rightarrow y = \frac{6.4 \sin 24^\circ}{\sin 120^\circ} = 3.0058$$

$$\Rightarrow y = 3.01 \text{ (3 s.f.)}$$

(The above approach finds the two values independently. You could find y first and then use it to find x , but then if y is wrong then so will x be.)

(f)

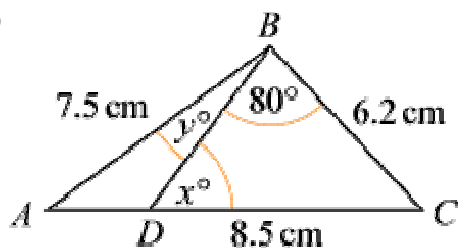

Using $\frac{\sin D}{d} = \frac{\sin B}{b}$ in $\triangle BDC$

$$\Rightarrow \frac{\sin x^\circ}{6.2} = \frac{\sin 80^\circ}{8.5}$$

$$\Rightarrow x^\circ = \frac{6.2 \sin 80^\circ}{8.5}$$

$$\Rightarrow x^\circ = \sin^{-1} \left(\frac{6.2 \sin 80^\circ}{8.5} \right) = 45.92^\circ$$

$$\Rightarrow x = 45.9 \text{ (3 s.f.)}$$

In $\triangle ABC$, $\angle ACB = 180^\circ - (80 + x)^\circ = 54.08^\circ$

Using $\frac{\sin A}{a} = \frac{\sin C}{c}$

$$\Rightarrow \frac{\sin A}{6.2} = \frac{\sin 54.08^\circ}{7.5}$$

$$\Rightarrow \sin A = \frac{6.2 \sin 54.08^\circ}{7.5}$$

$$\Rightarrow A = \sin^{-1} \left(\frac{6.2 \sin 54.08^\circ}{7.5} \right) = 42.03^\circ$$

So $y^\circ = 180^\circ - (42.03 + 134.1)^\circ = 3.87 \text{ (3 s.f.)}$

Solutionbank C2

Edexcel Modular Mathematics for AS and A-Level

The sine and cosine rule

Exercise B, Question 5

Question:

In $\triangle ABC$, $AB = x$ cm, $BC = (4 - x)$ cm, $\angle BAC = y^\circ$ and $\angle BCA = 30^\circ$.

Given that $\sin y^\circ = \frac{1}{\sqrt{2}}$, show that $x = 4(\sqrt{2} - 1)$.

Solution:

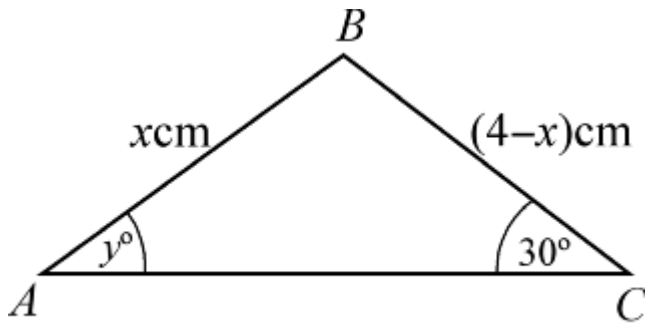

Using $\frac{a}{\sin A} = \frac{c}{\sin C}$

$$\Rightarrow \frac{4-x}{\sin y^\circ} = \frac{x}{\sin 30^\circ}$$

$$\Rightarrow (4-x) \sin 30^\circ = x \sin y^\circ$$

$$\Rightarrow (4-x) \times \frac{1}{2} = x \times \frac{1}{\sqrt{2}}$$

Multiply throughout by 2:

$$4-x = x\sqrt{2}$$

$$x + \sqrt{2}x = 4$$

$$x(1 + \sqrt{2}) = 4$$

$$x = \frac{4}{1 + \sqrt{2}}$$

Multiply 'top and bottom' by $\sqrt{2} - 1$:

$$x = \frac{4(\sqrt{2}-1)}{(\sqrt{2}-1)(\sqrt{2}+1)} = \frac{4(\sqrt{2}-1)}{2-1} = 4(\sqrt{2}-1)$$

Solutionbank C2

Edexcel Modular Mathematics for AS and A-Level

The sine and cosine rule

Exercise C, Question 1

Question:

(Give answers to 3 significant figures.)

In $\triangle ABC$, $BC = 6$ cm, $AC = 4.5$ cm and $\angle ABC = 45^\circ$:

(a) Calculate the two possible values of $\angle BAC$.

(b) Draw a diagram to illustrate your answers.

Solution:

(a)

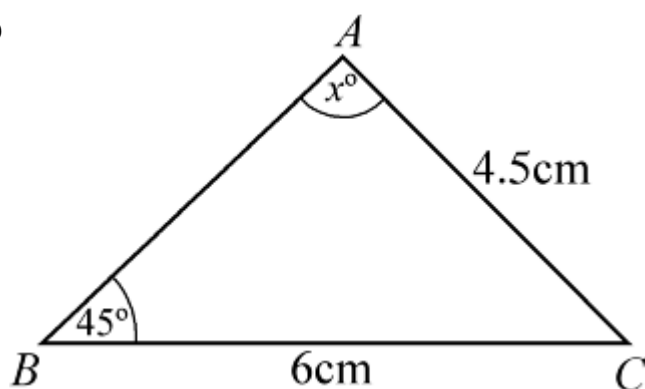

$$x > 45^\circ$$

So there are two possible results.

$$\text{Using } \frac{\sin A}{a} = \frac{\sin B}{b}$$

$$\frac{\sin x^\circ}{6} = \frac{\sin 45^\circ}{4.5}$$

$$\sin x^\circ = \frac{6 \sin 45^\circ}{4.5}$$

$$x^\circ = \sin^{-1} \left(\frac{6 \sin 45^\circ}{4.5} \right) \text{ or } 180^\circ - \sin^{-1} \left(\frac{6 \sin 45^\circ}{4.5} \right)$$

$$x^\circ = 70.5^\circ \text{ (3 s.f.) or } 109.5^\circ$$

(b)

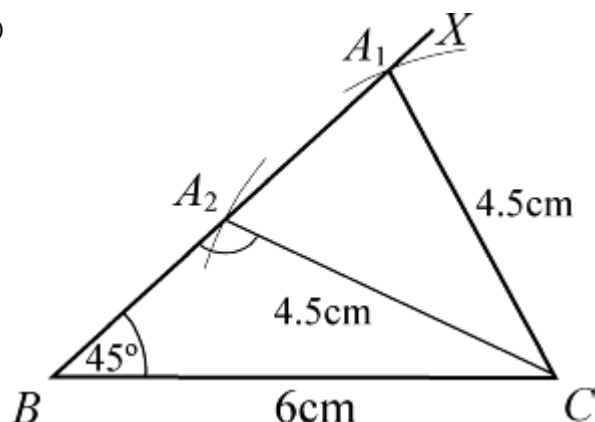

Draw $BC = 6$ cm.

Measure angle of 45° at B (BX).

Put compass point at C and open out to 4.5 cm. Where arc meets BX are the two possible positions of A .

© Pearson Education Ltd 2008

Solutionbank C2

Edexcel Modular Mathematics for AS and A-Level

The sine and cosine rule

Exercise C, Question 2

Question:

(Give answers to 3 significant figures.)

In each of the diagrams shown below, calculate the possible values of x and the corresponding values of y :

(a)

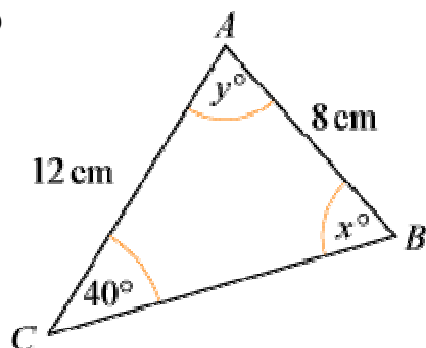

(b)

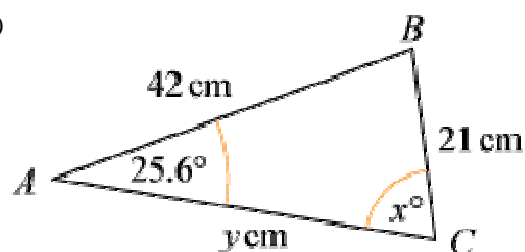

(c)

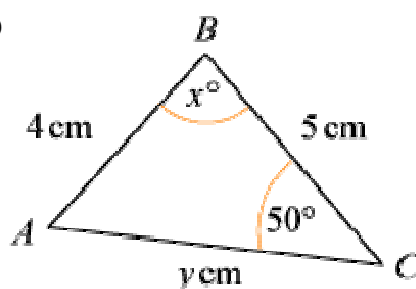

Solution:

(a)

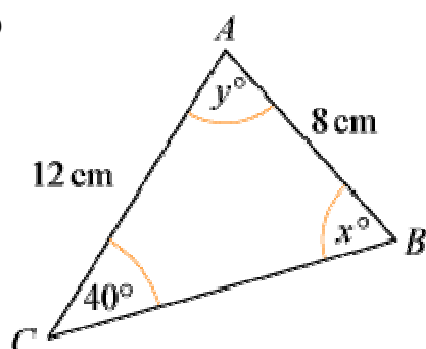

Using $\frac{\sin B}{b} = \frac{\sin C}{c}$

$$\frac{\sin x^\circ}{12} = \frac{\sin 40^\circ}{8}$$

$$\sin x^\circ = \frac{12 \sin 40^\circ}{8}$$

$$x^\circ = \sin^{-1} \left(\frac{12 \sin 40^\circ}{8} \right) \text{ or } 180^\circ - \sin^{-1} \left(\frac{12 \sin 40^\circ}{8} \right)$$

$$x^\circ = 74.6^\circ \text{ or } 105.4^\circ$$

$$x = 74.6 \text{ or } 105 \text{ (3 s.f.)}$$

When $x = 74.6$, $y = 180 - (74.6 + 40) = 180 - 114.6 = 65.4$ (3 s.f.)

When $x = 105.4$, $y = 180 - (105.4 + 40) = 180 - 145.4 = 34.6$ (3 s.f.)

(b)

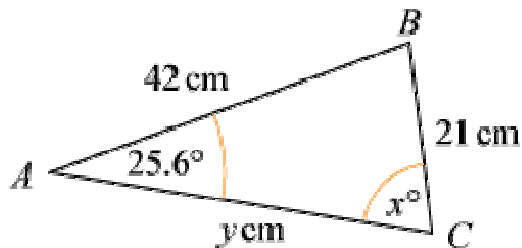

Using $\frac{\sin C}{c} = \frac{\sin A}{a}$

$$\frac{\sin x^\circ}{42} = \frac{\sin 25.6^\circ}{21}$$

$$\sin x^\circ = \frac{42 \sin 25.6^\circ}{21}$$

$$x^\circ = \sin^{-1} (2 \sin 25.6^\circ) \text{ or } 180^\circ - \sin^{-1} (2 \sin 25.6^\circ)$$

$$x^\circ = 59.79^\circ \text{ or } 120.2^\circ$$

$$x = 59.8 \text{ or } 120 \text{ (3 s.f.)}$$

When $x = 59.8$,

$$\text{angle } B = 180^\circ - (59.8^\circ + 25.6^\circ) = 94.6^\circ$$

Using $\frac{b}{\sin B} = \frac{a}{\sin A}$

$$\frac{y}{\sin 94.6^\circ} = \frac{21}{\sin 25.6^\circ} \Rightarrow y = \frac{21 \sin 94.6^\circ}{\sin 25.6^\circ} = 48.4 \text{ (3 s.f.)}$$

When $x = 120.2$,

$$\text{angle } B = 180^\circ - (120.2^\circ + 25.6^\circ) = 34.2^\circ$$

Using $\frac{b}{\sin B} = \frac{a}{\sin A}$

$$\frac{y}{\sin 34.2^\circ} = \frac{21}{\sin 25.6^\circ} \Rightarrow y = \frac{21 \sin 34.2^\circ}{\sin 25.6^\circ} = 27.3 \text{ (3 s.f.)}$$

(c)

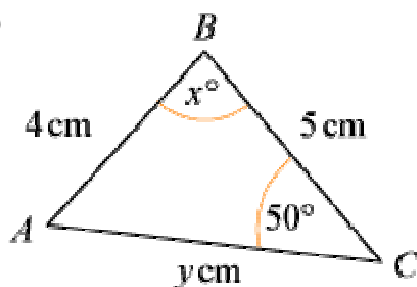

Using $\frac{\sin A}{a} = \frac{\sin C}{c}$

$$\frac{\sin A}{5} = \frac{\sin 50^\circ}{4}$$

$$\sin A = \frac{5 \sin 50^\circ}{4}$$

$$A = \sin^{-1} \left(\frac{5 \sin 50^\circ}{4} \right) \text{ or } 180^\circ - \sin^{-1} \left(\frac{5 \sin 50^\circ}{4} \right)$$

$$A = 73.25 \text{ or } 106.75$$

When $A = 73.247$,

$$x = 180 - (50 + 73.247) = 56.753 \quad \dots \quad = 56.8 \text{ (3 s.f.)}$$

Using $\frac{b}{\sin B} = \frac{c}{\sin C}$

$$\frac{y}{\sin x^\circ} = \frac{4}{\sin 50^\circ} \Rightarrow y = \frac{4 \sin x^\circ}{\sin 50^\circ} = 4.37 \text{ (3 s.f.)}$$

When $A = 106.75$,

$$x = 180 - (50 + 106.75) = 23.247 = 23.2 \text{ (3 s.f.)}$$

As above: $y = \frac{4 \sin x^\circ}{\sin 50^\circ} = 2.06 \text{ (3 s.f.)}$

© Pearson Education Ltd 2008

Solutionbank C2

Edexcel Modular Mathematics for AS and A-Level

The sine and cosine rule

Exercise C, Question 3

Question:

(Give answers to 3 significant figures.)

In each of the following cases $\triangle ABC$ has $\angle ABC = 30^\circ$ and $AB = 10$ cm:

(a) Calculate the least possible length that AC could be.

(b) Given that $AC = 12$ cm, calculate $\angle ACB$.

(c) Given instead that $AC = 7$ cm, calculate the two possible values of $\angle ACB$.

Solution:

(a)

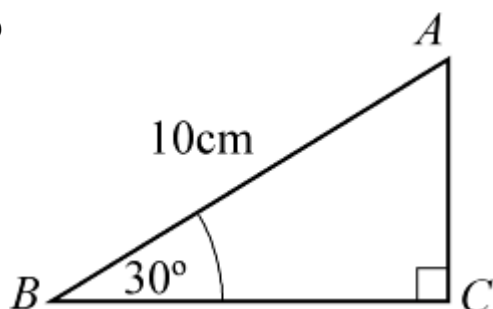

AC is least when it is at right angles to BC .

Using $\sin B = \frac{AC}{AB}$

$$\sin 30^\circ = \frac{AC}{10}$$

$$AC = 10 \sin 30^\circ = 5$$

$$AC = 5 \text{ cm}$$

(b)

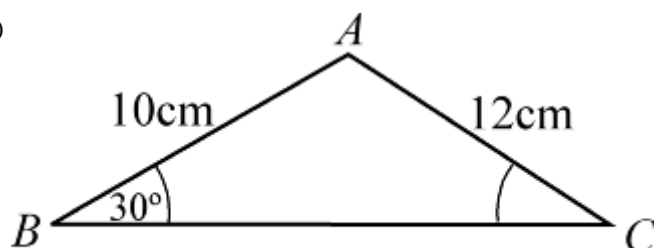

Using $\frac{\sin C}{c} = \frac{\sin B}{b}$

$$\frac{\sin C}{10} = \frac{\sin 30^\circ}{12}$$

$$\sin C = \frac{10 \sin 30^\circ}{12}$$

$$C = \sin^{-1} \left(\frac{10 \sin 30^\circ}{12} \right) = 24.62^\circ$$

$$\angle ACB = 24.6^\circ \text{ (3 s.f.)}$$

(c)

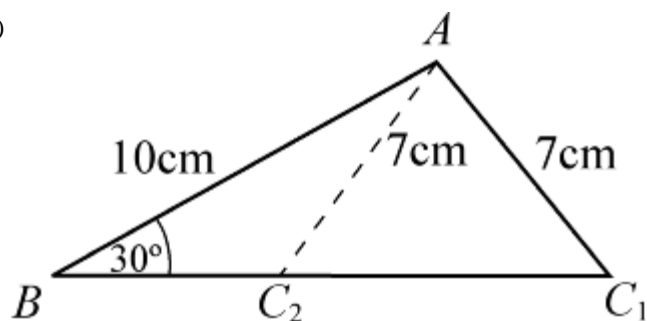

As $7 \text{ cm} < 10 \text{ cm}$, $\angle ACB > 30^\circ$ and there are two possible results.

Using 7 cm instead of 12 cm in (b):

$$\sin C = \frac{10 \sin 30^\circ}{7}$$

$$C = \sin^{-1} \left(\frac{10 \sin 30^\circ}{7} \right) \text{ or } 180^\circ - \sin^{-1} \left(\frac{10 \sin 30^\circ}{7} \right)$$

$$C = 45.58^\circ \text{ or } 134.4^\circ$$

$$\angle ACB = 45.6^\circ \text{ (3 s.f.) or } 134^\circ \text{ (3 s.f.)}$$

© Pearson Education Ltd 2008

Solutionbank C2

Edexcel Modular Mathematics for AS and A-Level

The sine and cosine rule

Exercise C, Question 4

Question:

(Give answers to 3 significant figures.)

Triangle ABC is such that $AB = 4$ cm, $BC = 6$ cm and $\angle ACB = 36^\circ$. Show that one of the possible values of $\angle ABC$ is 25.8° (to 3 s.f.). Using this value, calculate the length of AC .

Solution:

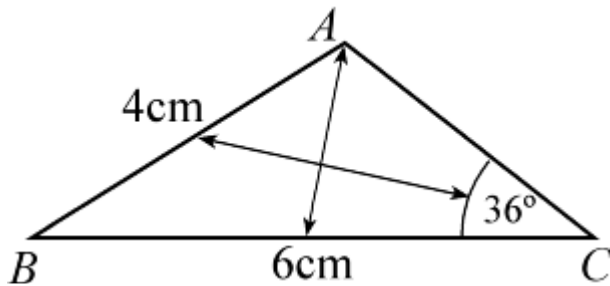

As $4 < 6$, $36^\circ < \angle BAC$, so there are two possible values for angle A .

$$\text{Using } \frac{\sin A}{a} = \frac{\sin C}{c}$$

$$\frac{\sin A}{6} = \frac{\sin 36^\circ}{4}$$

$$\sin A = \frac{6 \sin 36^\circ}{4}$$

$$A = \sin^{-1} \left(\frac{6 \sin 36^\circ}{4} \right) \text{ or } 180^\circ - \sin^{-1} \left(\frac{6 \sin 36^\circ}{4} \right)$$

$$A = 61.845 \dots^\circ \text{ or } 118.154 \dots^\circ$$

$$\text{When } A = 118.154 \dots^\circ$$

$$\angle ABC = 180^\circ - (36^\circ + 118.154 \dots^\circ) = 25.846 \dots^\circ = 25.8^\circ \text{ (3 s.f.)}$$

Using this value for $\angle ABC$ and $\frac{b}{\sin B} = \frac{c}{\sin C}$

$$\frac{AC}{\sin 25.8^\circ} = \frac{4}{\sin 36^\circ}$$

$$\Rightarrow AC = \frac{4 \sin 25.8^\circ}{\sin 36^\circ} = 2.96 \text{ cm (3 s.f.)}$$

Solutionbank C2

Edexcel Modular Mathematics for AS and A-Level

The sine and cosine rule

Exercise C, Question 5

Question:

(Give answers to 3 significant figures.)

Two triangles ABC are such that $AB = 4.5$ cm, $BC = 6.8$ cm and $\angle ACB = 30^\circ$. Work out the value of the largest angle in each of the triangles.

Solution:

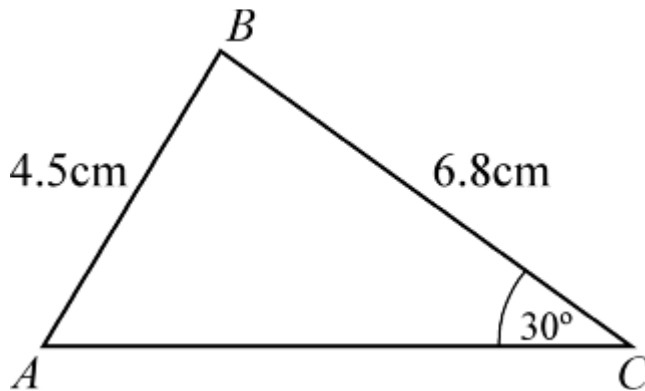

As $6.8 > 4.5$, angle $A > 30^\circ$ and so there are two possible values for A .

Using $\frac{\sin A}{a} = \frac{\sin C}{c}$

$$\frac{\sin A}{6.8} = \frac{\sin 30^\circ}{4.5}$$

$$A = \sin^{-1} \left(\frac{6.8 \sin 30^\circ}{4.5} \right) \text{ or } 180^\circ - \sin^{-1} \left(\frac{6.8 \sin 30^\circ}{4.5} \right)$$

$$A = 49.07 \dots^\circ \text{ or } 130.926 \dots^\circ$$

When $A = 49.07 \dots^\circ$, angle B is the largest angle

$$\angle ABC = 180^\circ - (30^\circ + 49.07 \dots^\circ) = 100.9 \dots^\circ = 101^\circ \text{ (3 s.f.)}$$

When $A = 130.926 \dots^\circ$, this will be the largest angle

$$\angle BAC = 131^\circ \text{ (3 s.f.)}$$

Solutionbank C2

Edexcel Modular Mathematics for AS and A-Level

The sine and cosine rule

Exercise D, Question 1

Question:

(Note: Give answers to 3 significant figures, where appropriate.)

In each of the following triangles calculate the length of the third side:

(a)

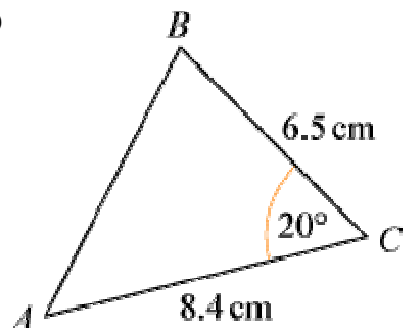

(b)

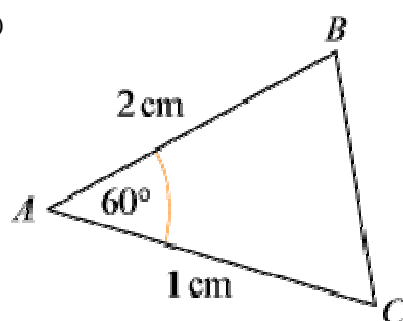

(c)

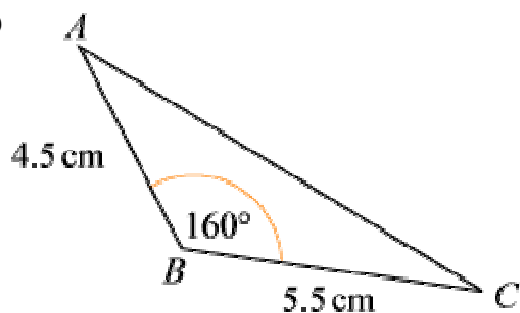

(d)

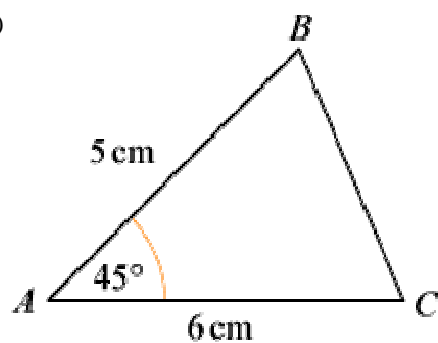

(e)

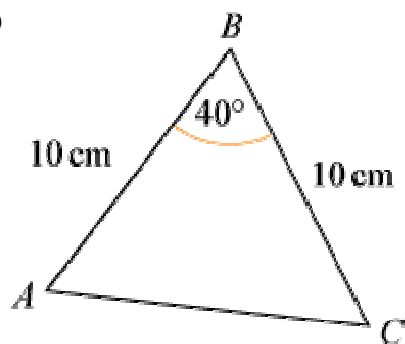

(f)

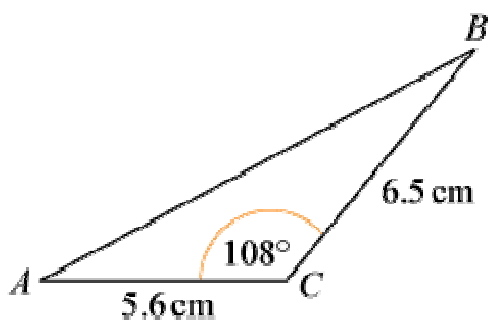
**Solution:**

(a)

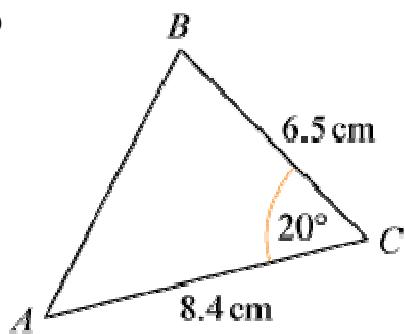
Using $c^2 = a^2 + b^2 - 2ab \cos C$

$$AB^2 = 6.5^2 + 8.4^2 - 2 \times 6.5 \times 8.4 \times \cos 20^\circ$$

$$AB^2 = 10.1955 \dots$$

$$AB = \sqrt{10.1955 \dots} = 3.19 \text{ cm (3 s.f.)}$$

(b)

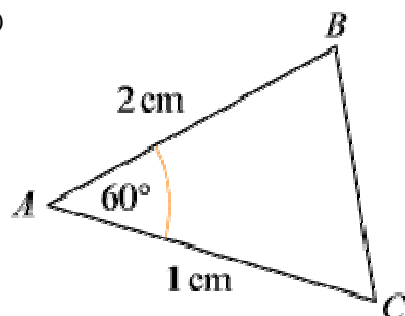
Using $a^2 = b^2 + c^2 - 2bc \cos A$

$$BC^2 = 1^2 + 2^2 - 2 \times 1 \times 2 \times \cos 60^\circ$$

$$BC^2 = 3$$

$$BC = \sqrt{3} = 1.73 \text{ cm (3 s.f.)}$$

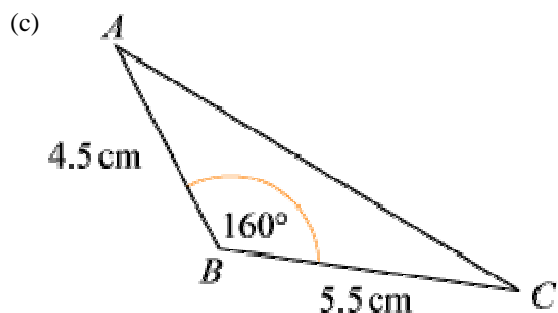

Using $b^2 = a^2 + c^2 - 2ac \cos B$
 $AC^2 = 5.5^2 + 4.5^2 - 2 \times 5.5 \times 4.5 \times \cos 160^\circ$
 $AC^2 = \frac{97.014 \dots}{97.014 \dots} = 9.85 \text{ cm (3 s.f.)}$

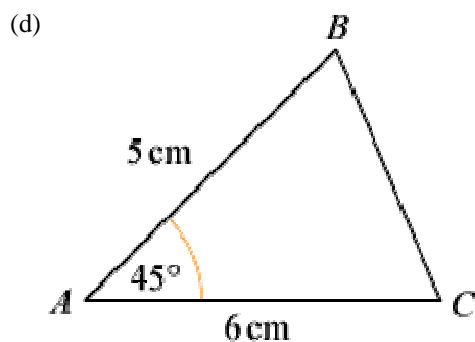

Using $a^2 = b^2 + c^2 - 2bc \cos A$
 $BC^2 = 6^2 + 5^2 - 2 \times 6 \times 5 \times \cos 45^\circ = 18.573 \dots$
 $BC = \sqrt{18.573 \dots} = 4.31 \text{ cm (3 s.f.)}$

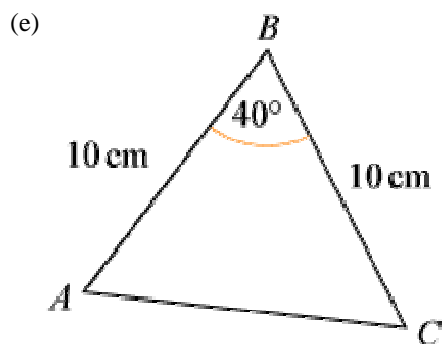

(This is an isosceles triangle and so you could use right-angled triangle work.)

Using $b^2 = a^2 + c^2 - 2ac \cos B$
 $AC^2 = \frac{10^2 + 10^2 - 2 \times 10 \times 10 \times \cos 40^\circ}{46.791 \dots} = 46.791 \dots$
 $AC = \sqrt{46.791 \dots} = 6.84 \text{ cm (3 s.f.)}$

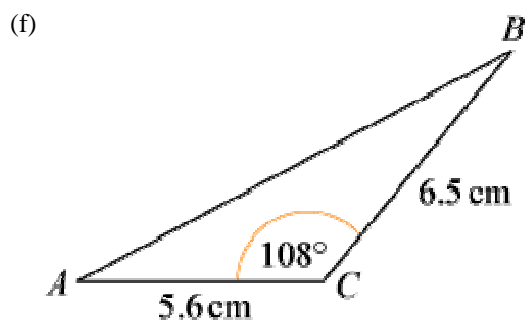

Using $c^2 = a^2 + b^2 - 2ab \cos C$

$$AB^2 = \frac{6.5^2 + 5.6^2 - 2 \times 6.5 \times 5.6 \times \cos 108^\circ}{\dots} = 96.106 \dots$$

$$AB = \sqrt{96.106 \dots} = 9.80 \text{ cm (3 s.f.)}$$

© Pearson Education Ltd 2008

Solutionbank C2

Edexcel Modular Mathematics for AS and A-Level

The sine and cosine rule

Exercise D, Question 2

Question:

(Note: Give answers to 3 significant figures, where appropriate.)

From a point A a boat sails due north for 7 km to B . The boat leaves B and moves on a bearing of 100° for 10 km until it reaches C . Calculate the distance of C from A .

Solution:

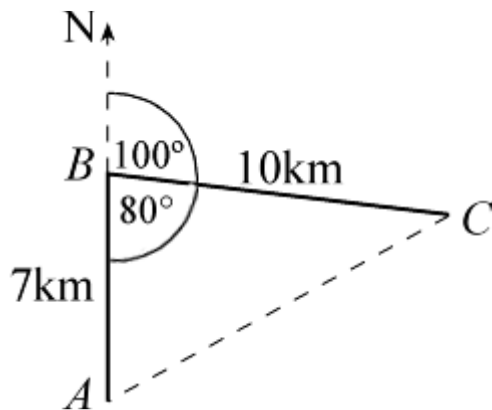

Using the cosine rule: $b^2 = a^2 + c^2 - 2ac \cos B$
 $AC^2 = 10^2 + 7^2 - 2 \times 10 \times 7 \times \cos 80^\circ = 124.689 \dots$
 $AC = \sqrt{124.689 \dots} = 11.2 \text{ km (3 s.f.)}$

© Pearson Education Ltd 2008

Solutionbank C2

Edexcel Modular Mathematics for AS and A-Level

The sine and cosine rule

Exercise D, Question 3

Question:

(Note: Give answers to 3 significant figures, where appropriate.)

The distance from the tee, T , to the flag, F , on a particular hole on a golf course is 494 yards. A golfer's tee shot travels 220 yards and lands at the point S , where $\angle STF = 22^\circ$. Calculate how far the ball is from the flag.

Solution:

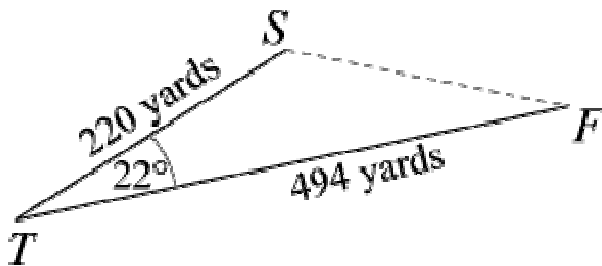

Using the cosine rule:

$$f^2 = s^2 + t^2 - 2st \cos T$$

$$SF^2 = 220^2 + 494^2 - 2 \times 220 \times 494 \cos 22^\circ = 90903.317 \dots$$

$$SF = \sqrt{90903.317 \dots} = 301.5 \dots \text{ yards} = 302 \text{ yards (3 s.f.)}$$

© Pearson Education Ltd 2008

Solutionbank C2

Edexcel Modular Mathematics for AS and A-Level

The sine and cosine rule

Exercise D, Question 4

Question:

(Note: Give answers to 3 significant figures, where appropriate.)

In $\triangle ABC$, $AB = (x - 3)$ cm, $BC = (x + 3)$ cm, $AC = 8$ cm and $\angle BAC = 60^\circ$. Use the cosine rule to find the value of x .

Solution:

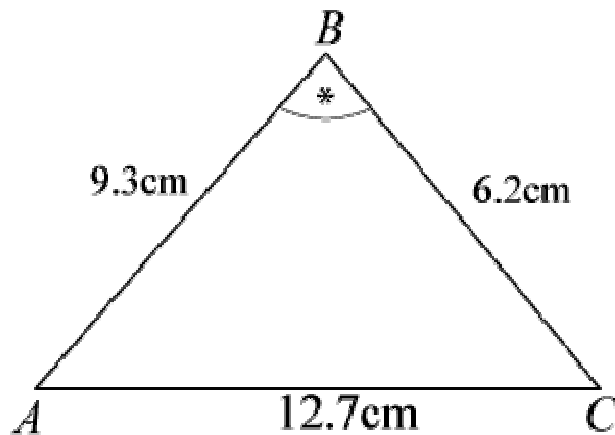

Using $a^2 = b^2 + c^2 - 2bc \cos A$

$$(x + 3)^2 = (x - 3)^2 + 8^2 - 2 \times 8 \times (x - 3) \cos 60^\circ$$

$$x^2 + 6x + 9 = x^2 - 6x + 9 + 64 - 8(x - 3)$$

$$x^2 + 6x + 9 = x^2 - 6x + 9 + 64 - 8x + 24$$

$$6x + 6x + 8x = 64 + 24$$

$$20x = 88$$

$$x = \frac{88}{20} = 4.4$$

Solutionbank C2

Edexcel Modular Mathematics for AS and A-Level

The sine and cosine rule

Exercise D, Question 5

Question:

(Note: Give answers to 3 significant figures, where appropriate.)

In $\triangle ABC$, $AB = x$ cm, $BC = (x - 4)$ cm, $AC = 10$ cm and $\angle BAC = 60^\circ$. Calculate the value of x .

Solution:

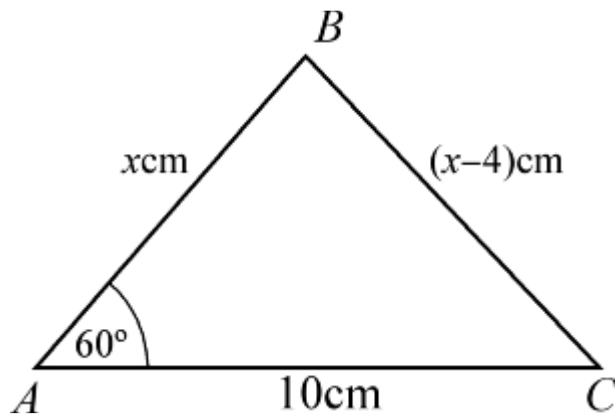

Using $a^2 = b^2 + c^2 - 2bc \cos A$

$$(x - 4)^2 = 10^2 + x^2 - 2 \times 10 \times x \cos 60^\circ$$

$$x^2 - 8x + 16 = 100 + x^2 - 10x$$

$$10x - 8x = 100 - 16$$

$$2x = 84$$

$$x = 42$$

© Pearson Education Ltd 2008

Solutionbank C2

Edexcel Modular Mathematics for AS and A-Level

The sine and cosine rule

Exercise D, Question 6

Question:

(Note: Give answers to 3 significant figures, where appropriate.)

In $\triangle ABC$, $AB = (5 - x)$ cm, $BC = (4 + x)$ cm, $\angle ABC = 120^\circ$ and $AC = y$ cm.

(a) Show that $y^2 = x^2 - x + 61$.

(b) Use the method of completing the square to find the minimum value of y^2 , and give the value of x for which this occurs.

Solution:

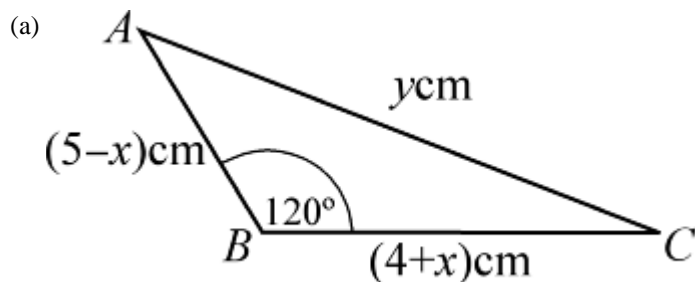

Using $b^2 = a^2 + c^2 - 2ac \cos B$

$$y^2 = (4 + x)^2 + (5 - x)^2 - 2(4 + x)(5 - x) \cos 120^\circ$$

$$y^2 = 16 + 8x + x^2 + 25 - 10x + x^2 + (4 + x)(5 - x) \quad (\text{Note: } 2 \cos 120^\circ = -1)$$

$$y^2 = 16 + 8x + x^2 + 25 - 10x + x^2 + 20 + x - x^2 = x^2 - x + 61$$

(b) Completing the square: $y^2 = \left(x - \frac{1}{2}\right)^2 + 61 - \frac{1}{4}$

$$\Rightarrow y^2 = \left(x - \frac{1}{2}\right)^2 + 60\frac{3}{4}$$

Minimum value of y^2 occurs when $\left(x - \frac{1}{2}\right)^2 = 0$, i.e. when $x = \frac{1}{2}$.

So minimum value of $y^2 = 60.75$.

Solutionbank C2

Edexcel Modular Mathematics for AS and A-Level

The sine and cosine rule

Exercise E, Question 1

Question:

(Give answers to 3 significant figures.)

In the following triangles calculate the size of the angle marked *:

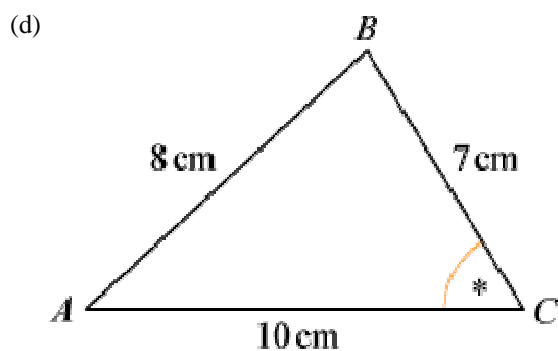
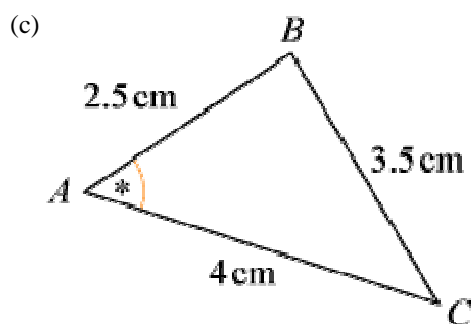
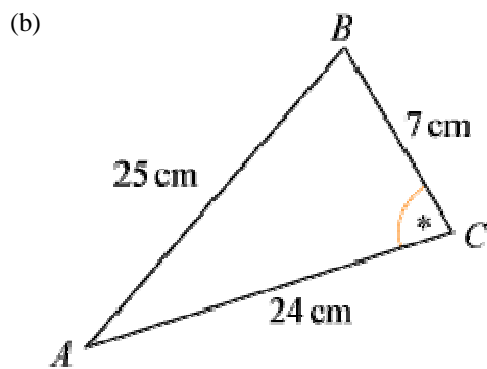
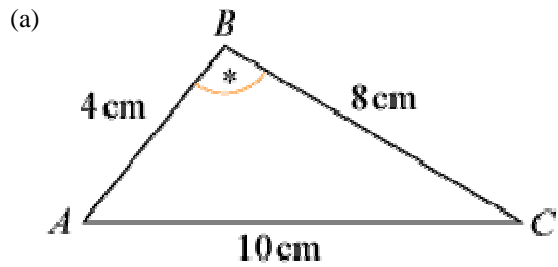

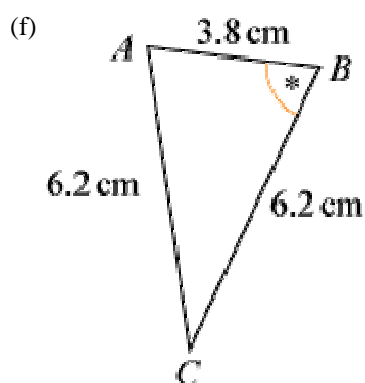
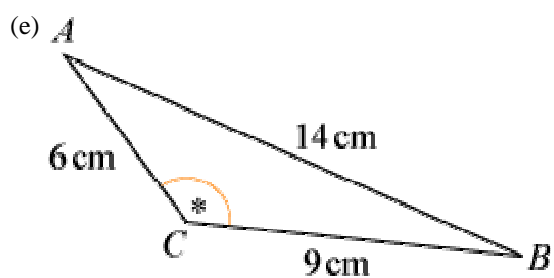

Solution:

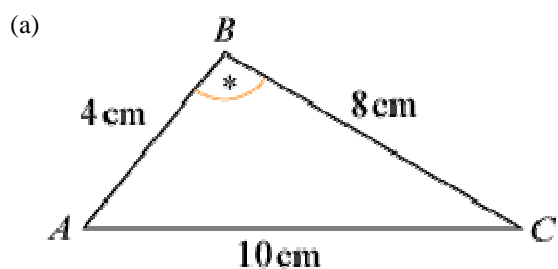

Using $\cos B = \frac{a^2 + c^2 - b^2}{2ac}$

$$\cos B = \frac{8^2 + 4^2 - 10^2}{2 \times 8 \times 4} = -\frac{20}{64} = -\frac{5}{16}$$

$$B = \cos^{-1} \left(-\frac{5}{16} \right) = 108.2 \dots^\circ = 108^\circ \text{ (3 s.f.)}$$

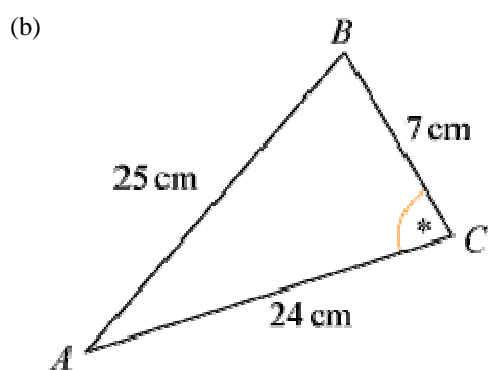

Using $\cos C = \frac{a^2 + b^2 - c^2}{2ab}$

$$\cos C = \frac{7^2 + 24^2 - 25^2}{2 \times 7 \times 24} = 0 \Rightarrow C = 90^\circ$$

(c)

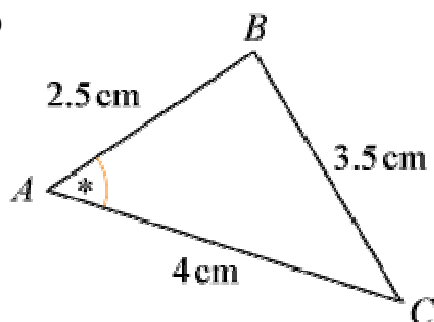

$$\text{Using } \cos A = \frac{b^2 + c^2 - a^2}{2bc}$$

$$\cos A = \frac{4^2 + 2.5^2 - 3.5^2}{2 \times 4 \times 2.5} = \frac{1}{2}$$

$$A = \cos^{-1} \left(\frac{1}{2} \right) = 60^\circ$$

(d)

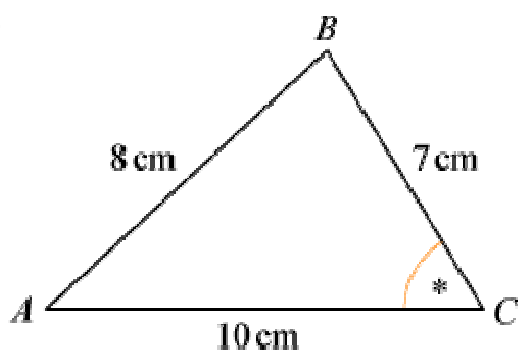

$$\text{Using } \cos C = \frac{a^2 + b^2 - c^2}{2ab}$$

$$\cos C = \frac{7^2 + 10^2 - 8^2}{2 \times 7 \times 10} = 0.6071 \dots$$

$$C = \cos^{-1}(0.6071\dots) = 52.6^\circ \text{ (3 s.f.)}$$

(e)

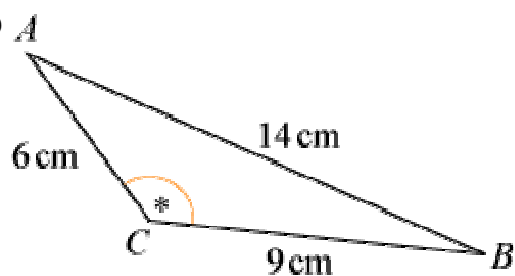

$$\text{Using } \cos C = \frac{a^2 + b^2 - c^2}{2ab}$$

$$\cos C = \frac{9^2 + 6^2 - 14^2}{2 \times 9 \times 6} = -0.7314 \dots \Rightarrow C = 137^\circ \text{ (3 s.f.)}$$

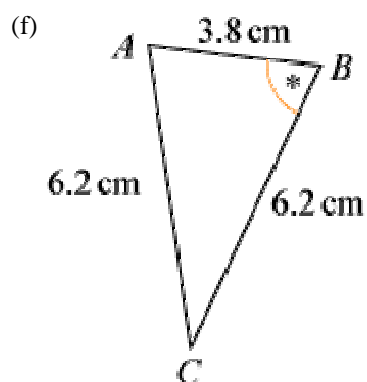

Using $\cos B = \frac{a^2 + c^2 - b^2}{2ac}$

$$\cos B = \frac{6.2^2 + 3.8^2 - 6.2^2}{2 \times 6.2 \times 3.8} = \frac{3.8}{2 \times 6.2} = 0.3064 \quad \dots \quad \Rightarrow \quad B = 72.2^\circ \quad (3 \text{ s.f.})$$

(This is an isosceles triangle so you could use right-angled triangle trigonometry.)

© Pearson Education Ltd 2008

Solutionbank C2

Edexcel Modular Mathematics for AS and A-Level

The sine and cosine rule

Exercise E, Question 2

Question:

(Give answers to 3 significant figures.)

A helicopter flies on a bearing of 080° from A to B , where $AB = 50$ km.

It then flies for 60 km to a point C .

Given that C is 80 km from A , calculate the bearing of C from A .

Solution:

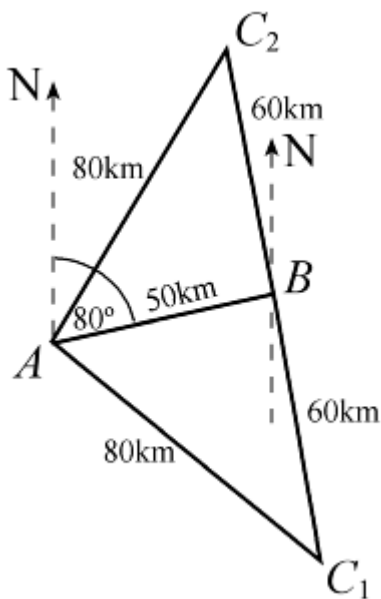

The bearing of C from B is not given so there are two possibilities for C using the data. The angle A will be the same in each $\triangle ABC$.

$$\text{Using } \cos A = \frac{b^2 + c^2 - a^2}{2bc}$$

$$\cos A = \frac{80^2 + 50^2 - 60^2}{2 \times 80 \times 50} = 0.6625$$

$$A = 48.5^\circ$$

$$\text{Bearing of } C \text{ from } A \text{ is } 80^\circ \pm 48.5^\circ = 128.5^\circ \text{ or } 31.5^\circ$$

Solutionbank C2

Edexcel Modular Mathematics for AS and A-Level

The sine and cosine rule

Exercise E, Question 3

Question:

(Give answers to 3 significant figures.)

In $\triangle ABC$, $AB = 5$ cm, $BC = 6$ cm and $AC = 10$ cm.
Calculate the value of the smallest angle.

Solution:

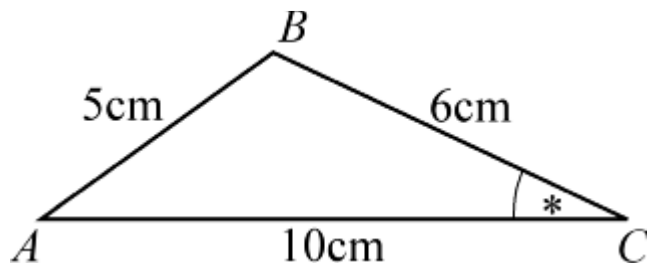

The smallest angle is C as this is opposite AB .

Using $\cos C = \frac{a^2 + b^2 - c^2}{2ab}$

$$\cos C = \frac{6^2 + 10^2 - 5^2}{2 \times 6 \times 10} = 0.925$$

$$C = 22.3^\circ \text{ (3 s.f.)}$$

© Pearson Education Ltd 2008

Solutionbank C2

Edexcel Modular Mathematics for AS and A-Level

The sine and cosine rule

Exercise E, Question 4

Question:

(Give answers to 3 significant figures.)

In $\triangle ABC$, $AB = 9.3$ cm, $BC = 6.2$ cm and $AC = 12.7$ cm.
Calculate the value of the largest angle.

Solution:

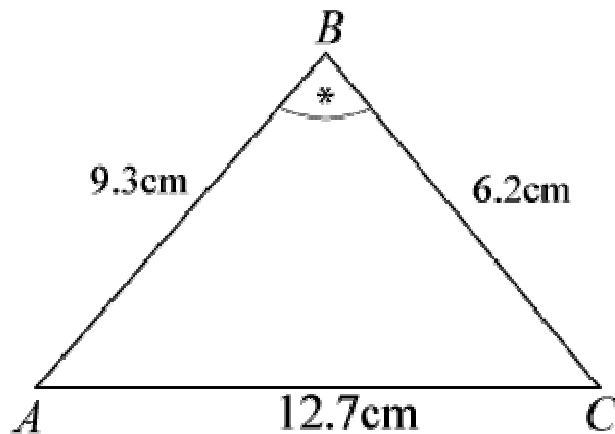

The largest angle is B as it is opposite AC .

Using $\cos B = \frac{a^2 + c^2 - b^2}{2ac}$

$$\cos B = \frac{6.2^2 + 9.3^2 - 12.7^2}{2 \times 6.2 \times 9.3} = -0.3152 \dots$$

$$B = 108.37 \dots = 108^\circ \text{ (3 s.f.)}$$

© Pearson Education Ltd 2008

Solutionbank C2

Edexcel Modular Mathematics for AS and A-Level

The sine and cosine rule

Exercise E, Question 5

Question:

(Give answers to 3 significant figures.)

The lengths of the sides of a triangle are in the ratio 2:3:4.
Calculate the value of the largest angle.

Solution:

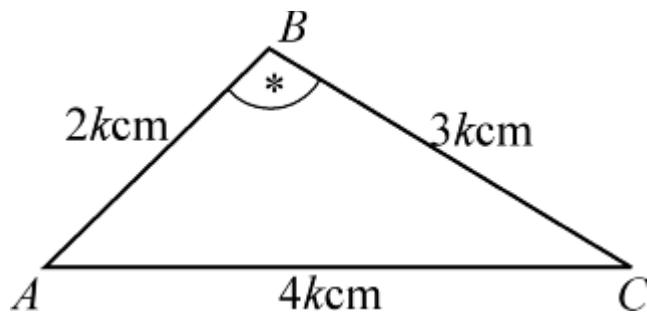

The largest angle will be opposite the side 4k cm.

$$\text{Using } \cos B = \frac{a^2 + c^2 - b^2}{2ac}$$

$$\cos B = \frac{9k^2 + 4k^2 - 16k^2}{2 \times 3k \times 2k} = -0.25$$

$$B = 104.477 \dots^\circ = 104^\circ \text{ (3 s.f.)}$$

© Pearson Education Ltd 2008

Solutionbank C2

Edexcel Modular Mathematics for AS and A-Level

The sine and cosine rule

Exercise E, Question 6

Question:

(Give answers to 3 significant figures.)

In $\triangle ABC$, $AB = x$ cm, $BC = 5$ cm and $AC = (10 - x)$ cm:

(a) Show that $\cos \angle ABC = \frac{4x - 15}{2x}$.

(b) Given that $\cos \angle ABC = -\frac{1}{7}$, work out the value of x .

Solution:

(a)

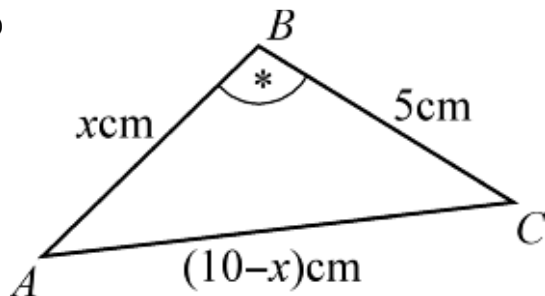

$$\begin{aligned} \cos B &= \frac{5^2 + x^2 - (10 - x)^2}{2 \times 5 \times x} \\ &= \frac{25 + x^2 - (100 - 20x + x^2)}{10x} \\ &= \frac{25 + x^2 - 100 + 20x - x^2}{10x} \\ &= \frac{20x - 75}{10x} \\ &= \frac{5(4x - 15)}{10x} \\ &= \frac{4x - 15}{2x} \end{aligned}$$

(b) As $\cos B = -\frac{1}{7}$

$$\frac{4x - 15}{2x} = -\frac{1}{7}$$

$$7(4x - 15) = -2x$$

$$28x - 105 = -2x$$

$$30x = 105$$

$$x = \frac{105}{30} = 3\frac{1}{2}$$

Solutionbank C2

Edexcel Modular Mathematics for AS and A-Level

The sine and cosine rule

Exercise F, Question 1

Question:

(Note: Try to use the neatest method, and give answers to 3 significant figures.)

In each triangle below find the values of x , y and z .

(a)

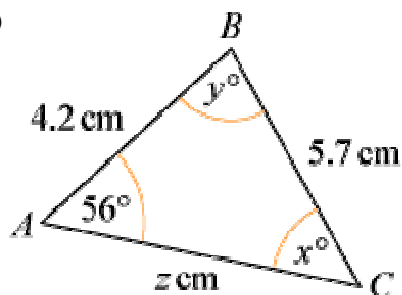

(b)

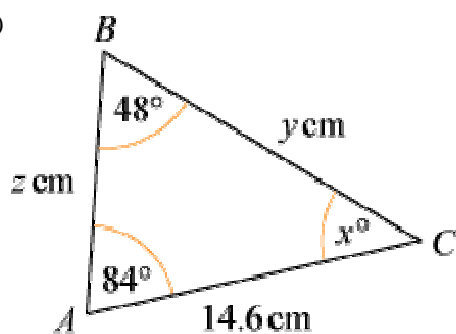

(c)

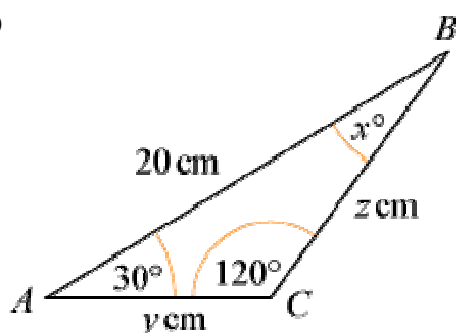

(d)

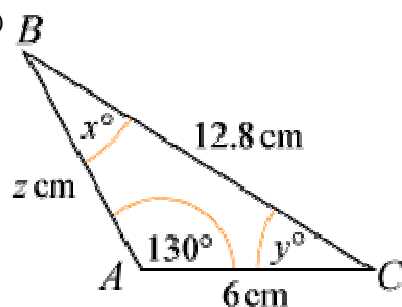

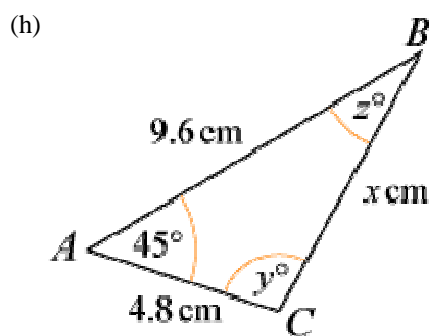
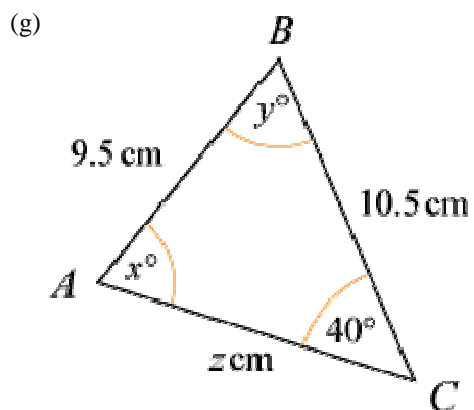
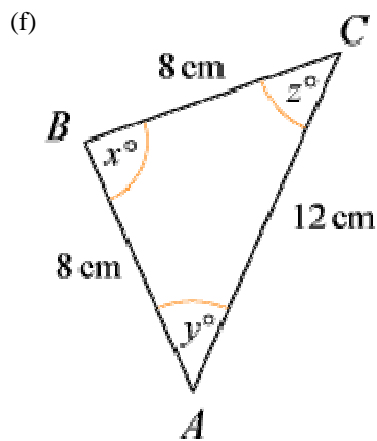
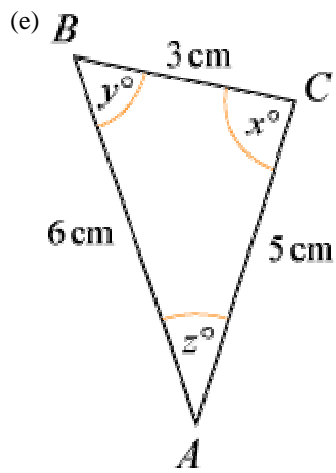

(i)

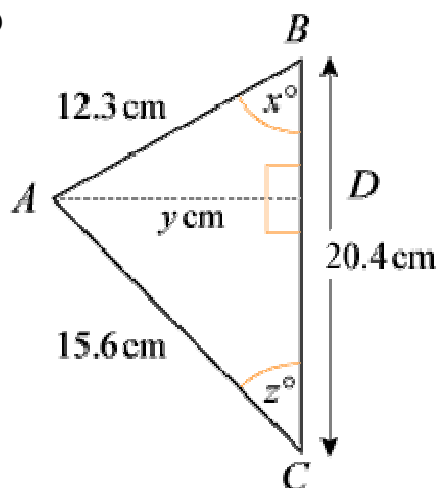
**Solution:**

(a)

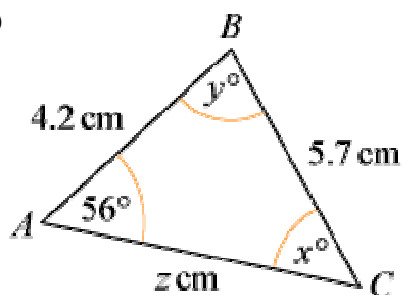

Using $\frac{\sin C}{c} = \frac{\sin A}{a}$

$$\frac{\sin x^\circ}{4.2} = \frac{\sin 56^\circ}{5.7}$$

$$\sin x^\circ = \frac{4.2 \sin 56^\circ}{5.7}$$

$$x^\circ = \sin^{-1} \left(\frac{4.2 \sin 56^\circ}{5.7} \right) = 37.65 \dots^\circ$$

$$x = 37.7 \text{ (3 s.f.)}$$

$$\text{So } y^\circ = 180^\circ - (56^\circ + 37.7^\circ) = 86.3^\circ$$

$$y = 86.3 \text{ (3 s.f.)}$$

Using $\frac{b}{\sin B} = \frac{a}{\sin A}$

$$\frac{z}{\sin y^\circ} = \frac{5.7}{\sin 56^\circ} \Rightarrow z = \frac{5.7 \sin y^\circ}{\sin 56^\circ} = 6.86 \text{ (3 s.f.)}$$

$$(b) x^\circ = 180^\circ - (48^\circ + 84^\circ) = 48^\circ \Rightarrow x = 48$$

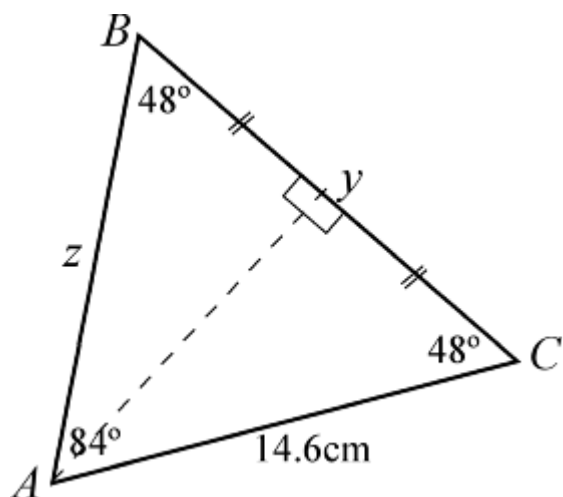

As $\angle B = \angle C$, $z = 14.6$

Using the line of symmetry through A

$$\cos 48^\circ = \frac{\frac{y}{2}}{14.6}$$

$$\Rightarrow y = 29.2 \cos 48^\circ = 19.5 \text{ (3 s.f.)}$$

(c)

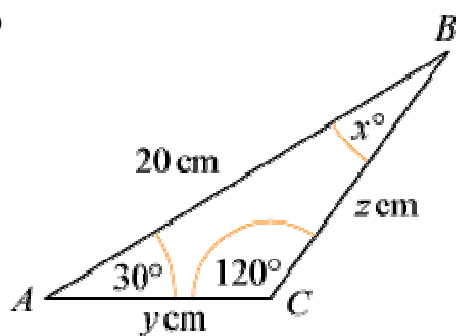

$$x^\circ = 180^\circ - (120^\circ + 30^\circ) = 30^\circ$$

Using the line of symmetry through C

$$\cos 30^\circ = \frac{10}{y} \Rightarrow y = \frac{10}{\cos 30^\circ} = 11.5 \text{ (3 s.f.)}$$

As $\triangle ABC$ is isosceles with $AC = CB$, $z = 11.5$ (3 s.f.)

(d)

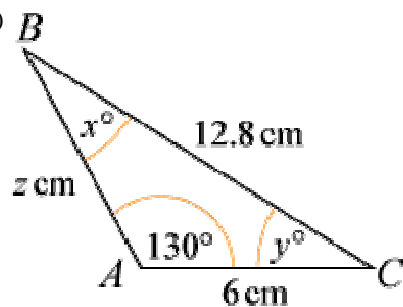

$$\text{Using } \frac{\sin A}{a} = \frac{\sin B}{b}$$

$$\frac{\sin 130^\circ}{12.8} = \frac{\sin x^\circ}{6} \Rightarrow \sin x^\circ = \frac{6 \sin 130^\circ}{12.8} = 0.35908 \dots$$

$$\Rightarrow x = 21.0 \text{ (3 s.f.)}$$

$$\text{So } y^\circ = 180^\circ - (130^\circ + x^\circ) = 28.956 \dots^\circ \Rightarrow y = 29.0 \text{ (3 s.f.)}$$

$$\text{Using } \frac{c}{\sin C} = \frac{a}{\sin A}$$

$$\frac{z}{\sin y^\circ} = \frac{12.8}{\sin 130^\circ}$$

$$\Rightarrow z = \frac{12.8 \sin y^\circ}{\sin 130^\circ} = 8.09 \text{ (3 s.f.)}$$

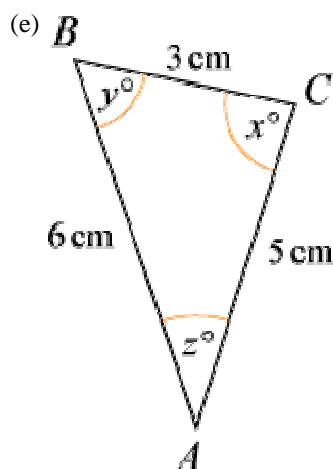

$$\text{Using } \cos C = \frac{a^2 + b^2 - c^2}{2ab}$$

$$\cos x^\circ = \frac{3^2 + 5^2 - 6^2}{2 \times 3 \times 5} = -0.06$$

$$x = 93.8 \text{ (3 s.f.)}$$

$$\text{Using } \frac{\sin B}{b} = \frac{\sin C}{c}$$

$$\frac{\sin y^\circ}{5} = \frac{\sin x^\circ}{6}$$

$$\sin y^\circ = \frac{5 \sin x^\circ}{6}$$

$$y^\circ = \sin^{-1} \left(\frac{5 \sin x^\circ}{6} \right) = 56.25 \dots^\circ$$

$$y = 56.3 \text{ (3 s.f.)}$$

Using angle sum for a triangle

$$z^\circ = 180^\circ - (x + y)^\circ = 29.926 \dots^\circ$$

$$z = 29.9 \text{ (3 s.f.)}$$

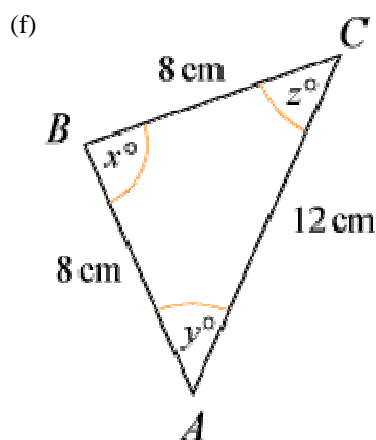

Using the line of symmetry through B

$$\cos y^\circ = \frac{6}{8}$$

$$y^\circ = \cos^{-1} \left(\frac{3}{4} \right) = 41.40 \dots$$

$$y = 41.4 \text{ (3 s.f.)}$$

As triangle is isosceles

$$z = y = 41.4 \text{ (3 s.f.)}$$

$$\text{So } x^\circ = 180^\circ - (y + z)^\circ = 97.2^\circ$$

$$x = 97.2 \text{ (3 s.f.)}$$

(g)

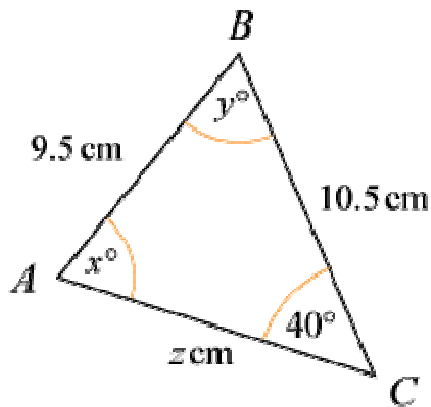

$$\text{Using } \frac{\sin A}{a} = \frac{\sin C}{c}$$

$$\frac{\sin x^\circ}{10.5} = \frac{\sin 40^\circ}{9.5}$$

$$\sin x^\circ = \frac{10.5 \sin 40^\circ}{9.5}$$

$$x^\circ = \sin^{-1} \left(\frac{10.5 \sin 40^\circ}{9.5} \right) \text{ or } 180^\circ - \sin^{-1} \left(\frac{10.5 \sin 40^\circ}{9.5} \right)$$

$$x^\circ = 45.27^\circ \text{ or } 134.728 \dots^\circ$$

$$x = 45.3 \text{ (3 s.f.) or } 135 \text{ (3 s.f.)}$$

$$\text{Using sine rule: } \frac{b}{\sin B} = \frac{c}{\sin C}$$

$$\frac{z}{\sin y^\circ} = \frac{9.5}{\sin 40^\circ}$$

$$z = \frac{9.5 \sin y^\circ}{\sin 40^\circ}$$

When $x = 45.3$

$$y^\circ = 180^\circ - (40 + 45.3)^\circ = 94.7^\circ \text{ so } y = 94.7 \text{ (3 s.f.)}$$

$$z = \frac{9.5 \sin y^\circ}{\sin 40^\circ} = 14.7 \text{ (3 s.f.)}$$

When $x = 134.72 \dots^\circ$

$$y^\circ = 180^\circ - (40 + 134.72 \dots)^\circ = 5.27^\circ \Rightarrow y = 5.27 \text{ (3 s.f.)}$$

$$z = \frac{9.5 \sin y^\circ}{\sin 40^\circ} = 1.36 \text{ (3 s.f.)}$$

$$\text{So } x = 45.3, y = 94.7, z = 14.7$$

$$\text{or } x = 135, y = 5.27, z = 1.36$$

(h)

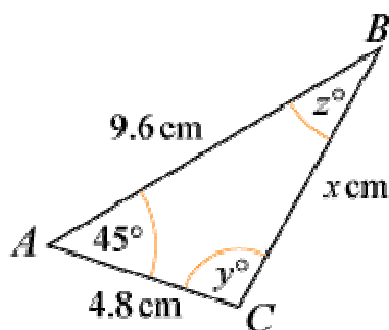
Using $a^2 = b^2 + c^2 - 2bc \cos A$

$$x^2 = 4.8^2 + 9.6^2 - 2 \times 4.8 \times 9.6 \times \cos 45^\circ = 50.03 \quad \dots$$

$$x = 7.07 \text{ (3 s.f.)}$$

Using $\frac{\sin C}{c} = \frac{\sin A}{a}$ (As $9.6 > x$, $y > 45$ and there are two possible values for y .)

$$\frac{\sin y^\circ}{9.6} = \frac{\sin 45^\circ}{x}$$

$$\sin y^\circ = \frac{9.6 \sin 45^\circ}{x}$$

$$y^\circ = \sin^{-1} \left(\frac{9.6 \sin 45^\circ}{x} \right) \text{ or } 180^\circ - \sin^{-1} \left(\frac{9.6 \sin 45^\circ}{x} \right)$$

$$y^\circ = 73.67 \quad \dots \quad \text{or } 106.32 \quad \dots \quad \text{or } 106 \text{ (3 s.f.)}$$

$$y = 73.7 \text{ (3 s.f.) or } 106 \text{ (3 s.f.)}$$

When $y = 73.67 \quad \dots$

$$z^\circ = 180^\circ - (45 + 73.67 \quad \dots)^\circ = 61.32 \quad \dots \quad \text{or } 61.3 \text{ (3 s.f.)}$$

$$z = 61.3 \text{ (3 s.f.)}$$

When $y = 106.32 \quad \dots$

$$z^\circ = 180^\circ - (45 + 106.32 \quad \dots)^\circ = 28.67 \quad \dots \quad \text{or } 28.7 \text{ (3 s.f.)}$$

$$z = 28.7 \text{ (3 s.f.)}$$

So $x = 7.07$, $y = 73.7$, $z = 61.3$ or $x = 7.07$, $y = 106$, $z = 28.7$

(i)

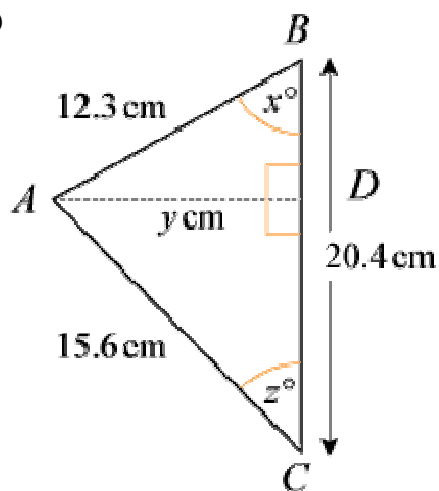
Using $\cos B = \frac{a^2 + c^2 - b^2}{2ac}$

$$\cos x^\circ = \frac{20.4^2 + 12.3^2 - 15.6^2}{2 \times 20.4 \times 12.3} = 0.6458 \quad \dots$$

$$x^\circ = 49.77 \quad \dots \quad \text{or } 49.8 \text{ (3 s.f.)}$$

$$x = 49.8 \text{ (3 s.f.)}$$

In the right-angled $\triangle ABD$

$$\sin x^\circ = \frac{y}{12.3} \Rightarrow y = 12.3 \sin x^\circ = 9.39 \text{ (3 s.f.)}$$

In right-angled $\triangle ACD$

$$\sin z^\circ = \frac{y}{15.6} = 0.60199 \dots$$

$$z^\circ = 37.01 \dots^\circ$$

$$z = 37.0 \text{ (3 s.f.)}$$

$$\text{So } x = 49.8, y = 9.39, z = 37.0$$

© Pearson Education Ltd 2008

Solutionbank C2

Edexcel Modular Mathematics for AS and A-Level

The sine and cosine rule

Exercise F, Question 2

Question:

(Note: Try to use the neatest method, and give answers to 3 significant figures.)

Calculate the size of the remaining angles and the length of the third side in the following triangles:

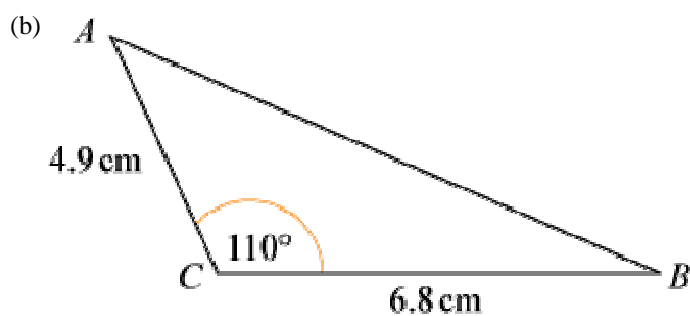
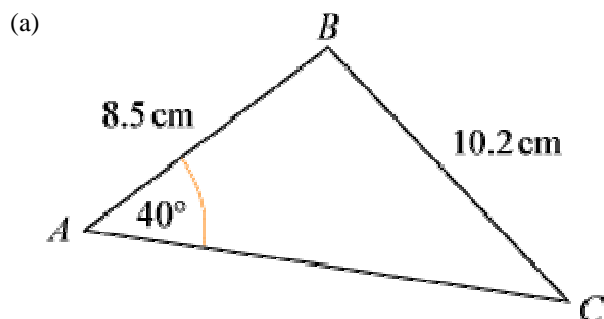

Solution:

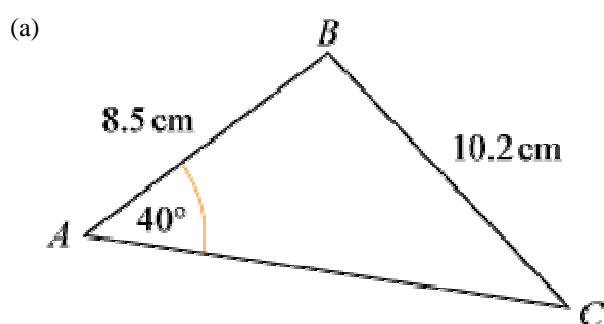

Using $\frac{\sin C}{c} = \frac{\sin A}{a}$

$$\frac{\sin C}{8.5} = \frac{\sin 40^\circ}{10.2}$$

$$\sin C = \frac{8.5 \sin 40^\circ}{10.2}$$

$$C = \sin^{-1} \left(\frac{8.5 \sin 40^\circ}{10.2} \right) = 32.388 \dots^\circ$$

$$C = 32.4^\circ \text{ (3 s.f.)}$$

$$\text{Angle } B = 180^\circ - (40 + C)^\circ = 107.6 \dots^\circ$$

$$B = 108^\circ \text{ (3 s.f.)}$$

$$\text{Using } \frac{b}{\sin B} = \frac{a}{\sin A}$$

$$b = \frac{10.2 \sin B}{\sin 40^\circ} = 15.1 \text{ cm (3 s.f.)}$$

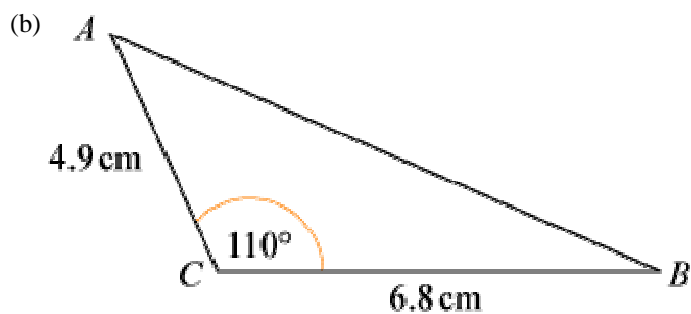

$$\text{Using } c^2 = a^2 + b^2 - 2ab \cos C$$

$$AB^2 = 6.8^2 + 4.9^2 - 2 \times 6.8 \times 4.9 \times \cos 110^\circ = 93.04 \dots$$

$$AB = 9.6458 \dots = 9.65 \text{ cm (3 s.f.)}$$

$$\text{Using } \frac{\sin A}{a} = \frac{\sin C}{c}$$

$$\sin A = \frac{6.8 \sin 110^\circ}{AB} = 0.66245 \dots$$

$$A = 41.49^\circ = 41.5^\circ \text{ (3 s.f.)}$$

$$\text{So } B = 180^\circ - (110 + A)^\circ = 28.5^\circ \text{ (3 s.f.)}$$

Solutionbank C2

Edexcel Modular Mathematics for AS and A-Level

The sine and cosine rule

Exercise F, Question 3

Question:

(Note: Try to use the neatest method, and give answers to 3 significant figures.)

A hiker walks due north from A and after 8 km reaches B . She then walks a further 8 km on a bearing of 120° to C . Work out (a) the distance from A to C and (b) the bearing of C from A .

Solution:

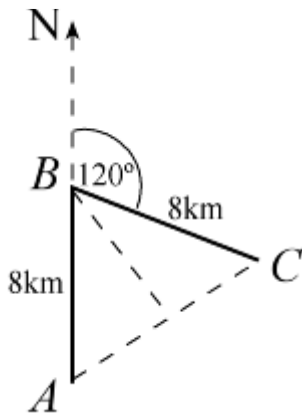

(a) $\angle ABC = 180^\circ - 120^\circ = 60^\circ$

As $\angle A = \angle C$, all angles are 60° ; it is an equilateral triangle.

So $AC = 8$ km.

(b) As $\angle BAC = 60^\circ$,

the bearing of C from A is 060° .

© Pearson Education Ltd 2008

Solutionbank C2

Edexcel Modular Mathematics for AS and A-Level

The sine and cosine rule

Exercise F, Question 4

Question:

(Note: Try to use the neatest method, and give answers to 3 significant figures.)

A helicopter flies on a bearing of 200° from A to B , where $AB = 70$ km. It then flies on a bearing of 150° from B to C , where C is due south of A . Work out the distance of C from A .

Solution:

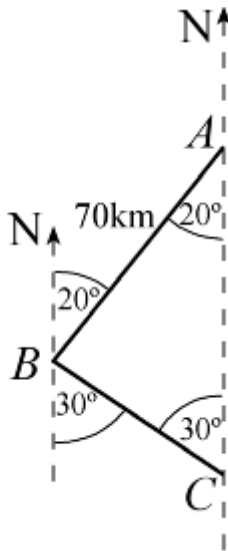

From the diagram $\angle ABC = 180^\circ - (20 + 30)^\circ = 130^\circ$

Using $\frac{b}{\sin B} = \frac{c}{\sin C}$

$$\frac{AC}{\sin 130^\circ} = \frac{70}{\sin 30^\circ}$$

$$AC = \frac{70 \sin 130^\circ}{\sin 30^\circ} = 107.246 \dots$$

$$AC = 107 \text{ km (3 s.f.)}$$

Solutionbank C2

Edexcel Modular Mathematics for AS and A-Level

The sine and cosine rule

Exercise F, Question 5

Question:

(Note: Try to use the neatest method, and give answers to 3 significant figures.)

Two radar stations A and B are 16 km apart and A is due north of B . A ship is known to be on a bearing of 150° from A and 10 km from B . Show that this information gives two positions for the ship, and calculate the distance between these two positions.

Solution:

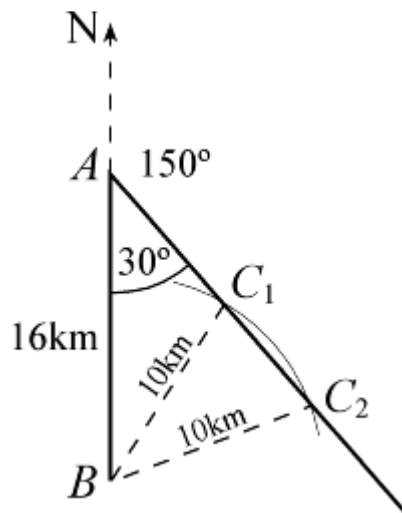

Using the sine rule: $\frac{\sin C}{c} = \frac{\sin A}{a}$

$$\frac{\sin C}{16} = \frac{\sin 30^\circ}{10}$$

$$\sin C = \frac{16 \sin 30^\circ}{10} = 0.8$$

$$C = \sin^{-1}(0.8) \text{ or } 180^\circ - \sin^{-1}(0.8)$$

$$C = 53.1^\circ \text{ or } 126.9^\circ$$

$$\angle AC_2B = 53.1^\circ, \angle AC_1B = 127^\circ \text{ (3 s.f.)}$$

(Store the correct values; these are not required answers.)

Triangle BC_1C_2 is isosceles, so C_1C_2 can be found using this triangle, without finding AC_1 and AC_2 .

Use the line of symmetry through B :

$$\cos \angle C_1C_2B = \frac{\frac{1}{2}C_1C_2}{10}$$

$$\Rightarrow C_1C_2 = 20 \cos \angle C_1C_2B = 20 \cos \angle AC_2B = 20 \cos 53.1^\circ$$

$$\Rightarrow C_1C_2 = 12 \text{ km}$$

Solutionbank C2

Edexcel Modular Mathematics for AS and A-Level

The sine and cosine rule

Exercise F, Question 6

Question:

(Note: Try to use the neatest method, and give answers to 3 significant figures.)

Find x in each of the following diagrams:

(a)

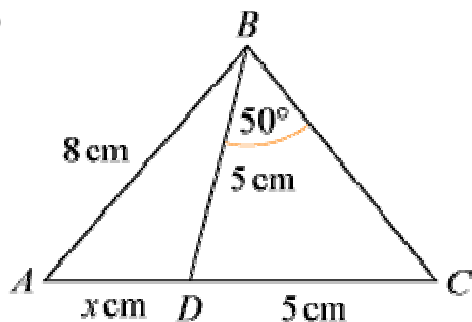

(b)

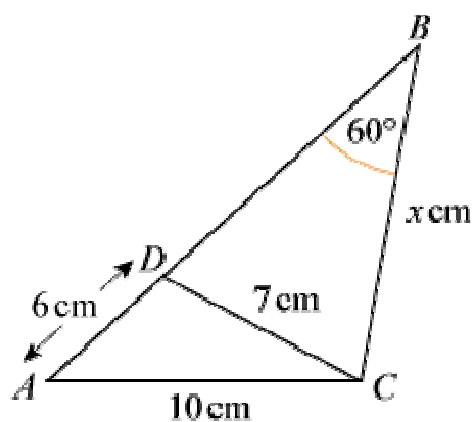

(c)

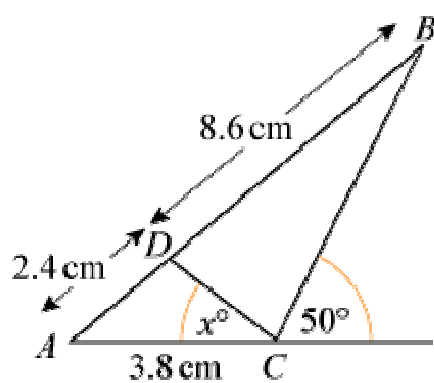

Solution:

(a)

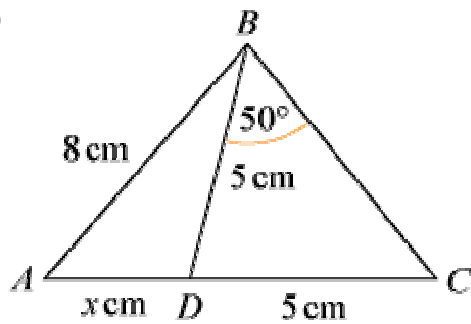

In the isosceles $\triangle BDC$: $\angle BDC = 180^\circ - (50 + 50)^\circ = 80^\circ$

So $\angle BDA = 180^\circ - 80^\circ = 100^\circ$

Using the sine rule in $\triangle ABD$: $\frac{\sin A}{a} = \frac{\sin D}{d}$

$$\Rightarrow \frac{\sin A}{5} = \frac{\sin 100^\circ}{8}$$

$$\Rightarrow \sin A = \frac{5 \sin 100^\circ}{8}$$

$$\text{So } A = \sin^{-1} \left(\frac{5 \sin 100^\circ}{8} \right) = 37.9886 \dots$$

Angle $ABD = 180^\circ - (100 + A)^\circ = 42.01 \dots^\circ$

Using $\frac{b}{\sin B} = \frac{d}{\sin D}$

$$\frac{x}{\sin B} = \frac{8}{\sin 100}$$

$$x = \frac{8 \sin B}{\sin 100^\circ} = 5.436 \dots$$

$$x = 5.44 \text{ (3 s.f.)}$$

(b)

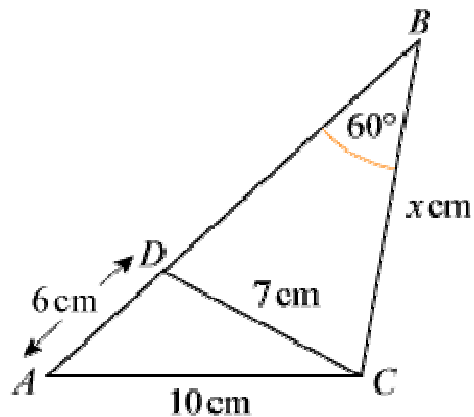

In $\triangle ADC$, using $\cos A = \frac{c^2 + d^2 - a^2}{2cd}$

$$\cos A = \frac{6^2 + 10^2 - 7^2}{2 \times 6 \times 10} = 0.725$$

So $A = 43.53 \dots^\circ$

Using the sine rule in $\triangle ABC$: $\frac{a}{\sin A} = \frac{b}{\sin B}$

$$\text{So } \frac{x}{\sin A} = \frac{10}{\sin 60^\circ}$$

$$\Rightarrow x = \frac{10 \sin A}{\sin 60^\circ} = 7.95 \text{ (3 s.f.)}$$

(c)

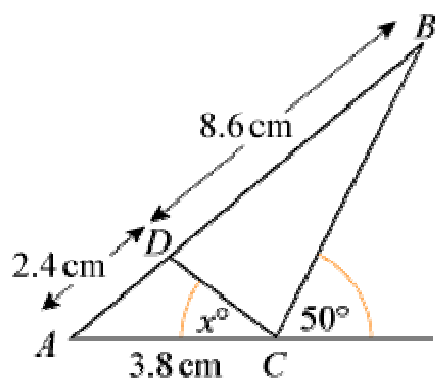

In $\triangle ABC$, $c = 11$ cm, $b = 3.8$ cm, $\angle ACB = 130^\circ$

Using $\frac{\sin B}{b} = \frac{\sin C}{c}$

$$\sin B = \frac{3.8 \sin 130^\circ}{11} = 0.2646 \dots$$

$$B = 15.345 \dots^\circ$$

$$\text{So } A = 180^\circ - (130 + B)^\circ = 34.654 \dots^\circ$$

In $\triangle ADC$, $c = 2.4$ cm, $d = 3.8$ cm, $A = 34.654 \dots^\circ$

Using the cosine rule: $a^2 = c^2 + d^2 - 2cd \cos A$

$$\text{So } DC^2 = 2.4^2 + 3.8^2 - 2 \times 2.4 \times 3.8 \times \cos A = 5.1959 \dots$$

$$\Rightarrow DC = 2.279 \dots \text{ cm.}$$

Using the sine rule: $\frac{\sin C}{c} = \frac{\sin A}{a}$

$$\sin x^\circ = \frac{2.4 \sin A}{DC} = 0.59869 \dots$$

$$x = 36.8 \text{ (3 s.f.)}$$

© Pearson Education Ltd 2008

Solutionbank C2

Edexcel Modular Mathematics for AS and A-Level

The sine and cosine rule

Exercise F, Question 7

Question:

(Note: Try to use the neatest method, and give answers to 3 significant figures.)

In $\triangle ABC$, shown below, $AB = 4$ cm, $BC = (x + 2)$ cm and $AC = 7$ cm.

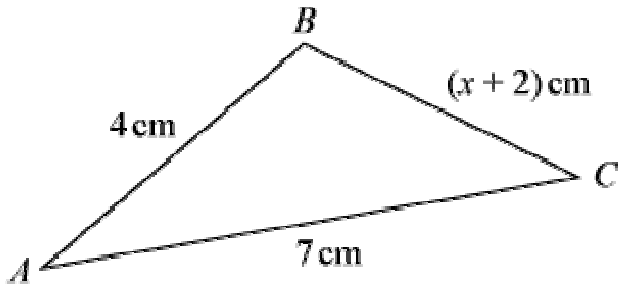

- (a) Explain how you know that $1 < x < 9$.
- (b) Work out the value of x for the cases when
- $\angle ABC = 60^\circ$ and
 - $\angle ABC = 45^\circ$, giving your answers to 3 significant figures.

Solution:

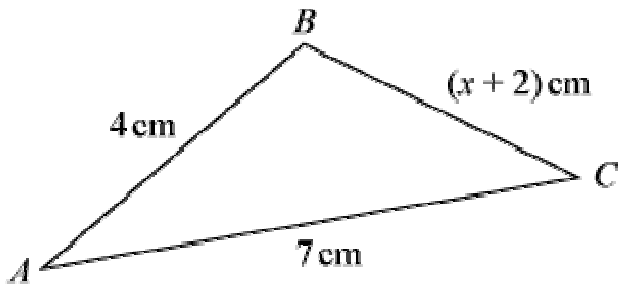

- (a) As $AB + BC > AC$

$$4 + (x + 2) > 7$$

$$\Rightarrow x + 2 > 3$$

$$\Rightarrow x > 1$$

- As $AB + AC > BC$

$$4 + 7 > x + 2$$

$$\Rightarrow 9 > x$$

So $1 < x < 9$

- (b) Using $b^2 = a^2 + c^2 - 2ac \cos B$

$$(i) 7^2 = (x + 2)^2 + 4^2 - 2 \times (x + 2) \times 4 \times \cos 60^\circ$$

$$49 = x^2 + 4x + 4 + 16 - 4(x + 2)$$

$$49 = x^2 + 4x + 4 + 16 - 4x - 8$$

$$\text{So } x^2 = 37$$

$$\Rightarrow x = 6.08 \text{ (3 s.f.)}$$

$$(ii) 7^2 = (x + 2)^2 + 4^2 - 2 \times (x + 2) \times 4 \times \cos 45^\circ$$

$$49 = x^2 + 4x + 4 + 16 - (8 \cos 45^\circ)x - 16 \cos 45^\circ$$

$$\text{So } x^2 + (4 - 8 \cos 45^\circ) x - (29 + 16 \cos 45^\circ) = 0$$

$$\text{or } x^2 + 4(1 - \sqrt{2}) x - (29 + 8\sqrt{2}) = 0$$

Use the quadratic equation formula $x = \frac{-b \pm \sqrt{b^2 - 4ac}}{2a}$ with

$$a = 1$$

$$b = 4 - 8 \cos 45^\circ = 4(1 - \sqrt{2}) = -1.6568 \dots$$

$$c = -(29 + 16 \cos 45^\circ) = -(29 + 8\sqrt{2}) = -40.313 \dots$$

$$x = 7.23 \text{ (3 s.f.) (The other value of } x \text{ is less than } -2.)$$

© Pearson Education Ltd 2008

Solutionbank C2

Edexcel Modular Mathematics for AS and A-Level

The sine and cosine rule

Exercise F, Question 8

Question:

(Note: Try to use the neatest method, and give answers to 3 significant figures.)

In the triangle shown below, $\cos \angle ABC = \frac{5}{8}$.

Calculate the value of x .

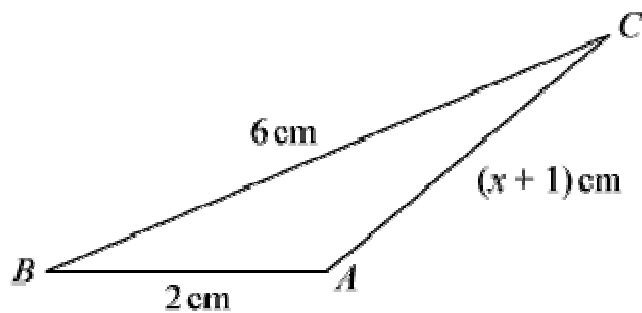

Solution:

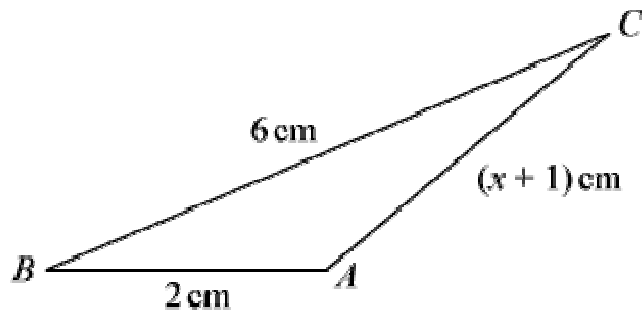

Using $b^2 = a^2 + c^2 - 2ac \cos B$ where $\cos B = \frac{5}{8}$

$$(x + 1)^2 = 6^2 + 2^2 - 2 \times 6 \times 2 \times \frac{5}{8}$$

$$x^2 + 2x + 1 = 36 + 4 - 15$$

$$x^2 + 2x - 24 = 0$$

$$(x + 6)(x - 4) = 0$$

$$\text{So } x = 4 \quad (x > -1)$$

Solutionbank C2

Edexcel Modular Mathematics for AS and A-Level

The sine and cosine rule

Exercise F, Question 9

Question:

(Note: Try to use the neatest method, and give answers to 3 significant figures.)

In $\triangle ABC$, $AB = \sqrt{2}$ cm, $BC = \sqrt{3}$ cm and $\angle BAC = 60^\circ$. Show that $\angle ACB = 45^\circ$ and find AC .

Solution:

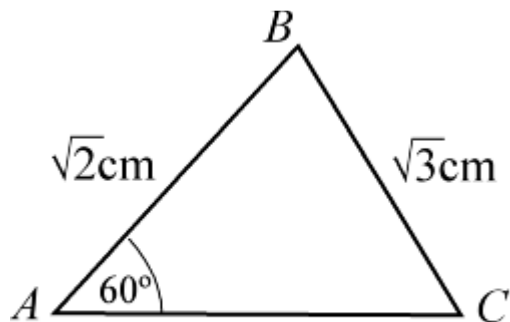

$$\text{Using } \frac{\sin C}{c} = \frac{\sin A}{a}$$

$$\sin C = \frac{\sqrt{2} \sin 60^\circ}{\sqrt{3}} = 0.7071 \dots$$

$$C = \sin^{-1} \left(\frac{\sqrt{2} \sin 60^\circ}{\sqrt{3}} \right) = 45^\circ$$

$$B = 180^\circ - (60 + 45)^\circ = 75^\circ$$

$$\text{Using } \frac{b}{\sin B} = \frac{a}{\sin A}$$

$$\frac{AC}{\sin 75^\circ} = \frac{\sqrt{3}}{\sin 60^\circ}$$

$$\text{So } AC = \frac{\sqrt{3} \sin 75^\circ}{\sin 60^\circ} = 1.93 \text{ cm (3 s.f.)}$$

Solutionbank C2

Edexcel Modular Mathematics for AS and A-Level

The sine and cosine rule

Exercise F, Question 10

Question:

(Note: Try to use the neatest method, and give answers to 3 significant figures.)

In $\triangle ABC$, $AB = (2 - x)$ cm, $BC = (x + 1)$ cm and $\angle ABC = 120^\circ$:

(a) Show that $AC^2 = x^2 - x + 7$.

(b) Find the value of x for which AC has a minimum value.

Solution:

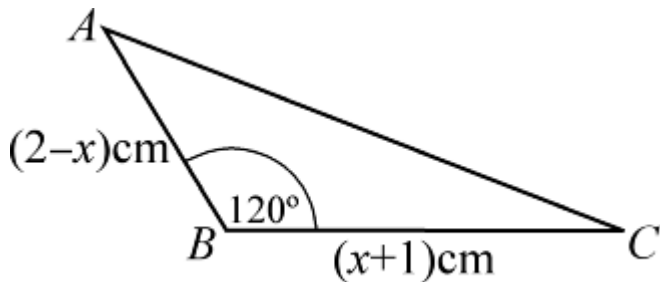

(a) Using the cosine rule: $b^2 = a^2 + c^2 - 2ac \cos B$
 $AC^2 = (x + 1)^2 + (2 - x)^2 - 2(x + 1)(2 - x) \cos 120^\circ$
 $AC^2 = (x^2 + 2x + 1) + (4 - 4x + x^2) + (x + 1)(2 - x)$
 $AC^2 = x^2 + 2x + 1 + 4 - 4x + x^2 - x^2 + 2x - x + 2$
 $AC^2 = x^2 - x + 7$

(b) Using the method of completing the square:

$$x^2 - x + 7 \equiv \left(x - \frac{1}{2}\right)^2 + 7 - \frac{1}{4} \equiv \left(x - \frac{1}{2}\right)^2 + 6\frac{3}{4}$$

This is a minimum when $x - \frac{1}{2} = 0$, i.e. $x = \frac{1}{2}$.

Solutionbank C2

Edexcel Modular Mathematics for AS and A-Level

The sine and cosine rule

Exercise F, Question 11

Question:

(Note: Try to use the neatest method, and give answers to 3 significant figures.)

Triangle ABC is such that $BC = 5\sqrt{2}$ cm, $\angle ABC = 30^\circ$ and $\angle BAC = \theta$, where $\sin \theta = \frac{\sqrt{5}}{8}$. Work out the length of AC , giving your answer in the form $a\sqrt{b}$, where a and b are integers.

Solution:

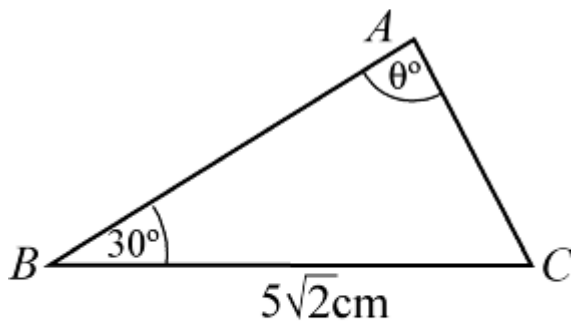

$$\text{Using } \frac{b}{\sin B} = \frac{a}{\sin A}$$

$$\frac{AC}{\sin 30^\circ} = \frac{5\sqrt{2}}{\sin \theta^\circ}$$

$$AC = \frac{5\sqrt{2} \sin 30^\circ}{\left(\frac{\sqrt{5}}{8}\right)}$$

$$AC = \frac{5\sqrt{2} \sin 30^\circ \times 8}{\sqrt{5}} = \left(\sqrt{5}\sqrt{2}\right) \left(8 \sin 30^\circ\right) = 4\sqrt{10}$$

Solutionbank C2

Edexcel Modular Mathematics for AS and A-Level

The sine and cosine rule

Exercise F, Question 12

Question:

(Note: Try to use the neatest method, and give answers to 3 significant figures.)

The perimeter of $\triangle ABC = 15$ cm. Given that $AB = 7$ cm and $\angle BAC = 60^\circ$, find the lengths AC and BC .

Solution:

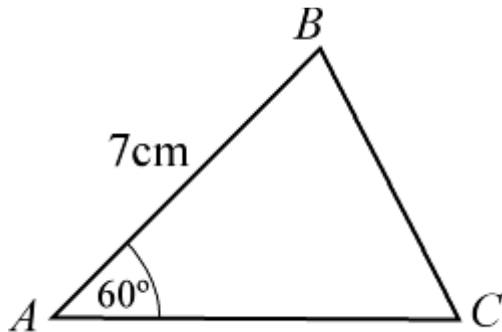

Using the cosine rule: $a^2 = b^2 + c^2 - 2bc \cos A$

with $a = x$, $b = (8 - x)$, $c = 7$ and $A = 60^\circ$

$$x^2 = (8 - x)^2 + 7^2 - 2(8 - x) \times 7 \times \cos 60^\circ$$

$$x^2 = 64 - 16x + x^2 + 49 - 7(8 - x)$$

$$x^2 = 64 - 16x + x^2 + 49 - 56 + 7x$$

$$\Rightarrow 9x = 57$$

$$\Rightarrow x = \frac{57}{9} = \frac{19}{3} = 6 \frac{1}{3}$$

So $BC = 6 \frac{1}{3}$ cm and $AC = \left(8 - 6 \frac{1}{3} \right)$ cm $= 1 \frac{2}{3}$ cm.

Solutionbank C2

Edexcel Modular Mathematics for AS and A-Level

The sine and cosine rule

Exercise G, Question 1

Question:

Calculate the area of the following triangles:

(a)

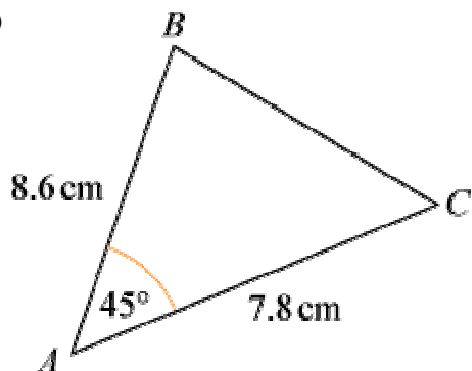

(b)

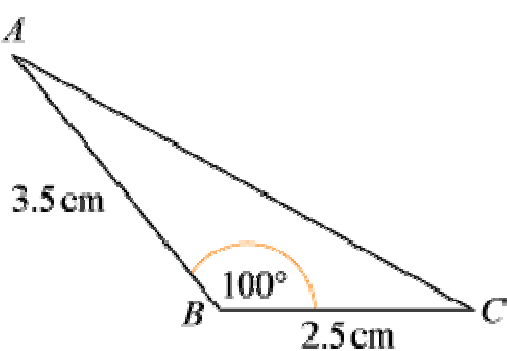

(c)

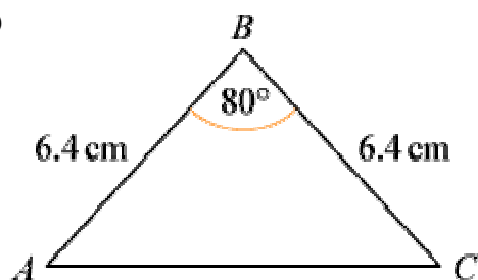

Solution:

(a)

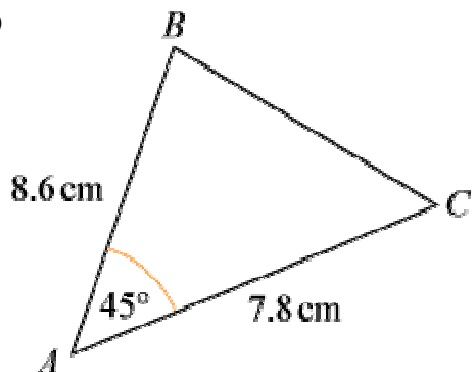

$$\text{Area} = \frac{1}{2} \times 7.8 \times 8.6 \times \sin 45^\circ = 23.71 \dots = 23.7 \text{ cm}^2 \text{ (3 s.f.)}$$

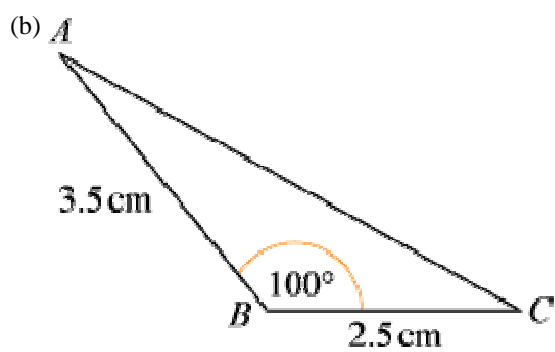

$$\text{Area} = \frac{1}{2} \times 2.5 \times 3.5 \times \sin 100^\circ = 4.308 \dots = 4.31 \text{ cm}^2 \text{ (3 s.f.)}$$

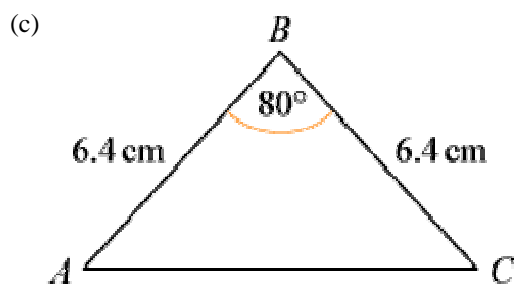

$$\text{Area} = \frac{1}{2} \times 6.4 \times 6.4 \times \sin 80^\circ = 20.16 \dots = 20.2 \text{ cm}^2 \text{ (3 s.f.)}$$

Solutionbank C2

Edexcel Modular Mathematics for AS and A-Level

The sine and cosine rule

Exercise G, Question 2

Question:

Work out the possible values of x in the following triangles:

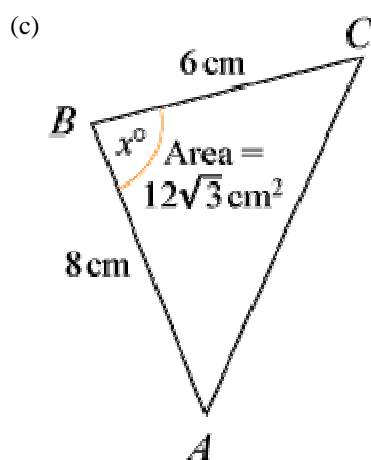
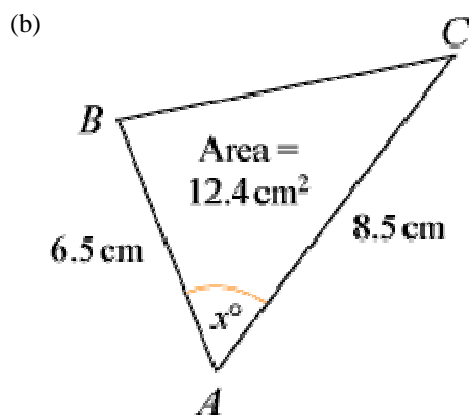
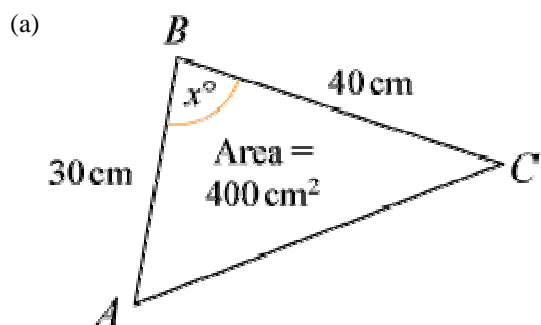

Solution:

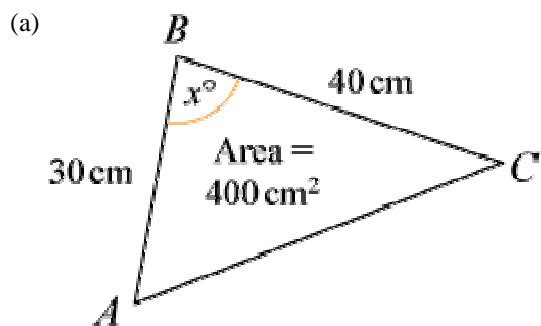

Using area = $\frac{1}{2}ac \sin B$

$$400 = \frac{1}{2} \times 40 \times 30 \times \sin x^\circ$$

$$\text{So } \sin x^\circ = \frac{400}{600} = \frac{2}{3}$$

$$x^\circ = \sin^{-1} \left(\frac{2}{3} \right) \text{ or } 180^\circ - \sin^{-1} \left(\frac{2}{3} \right)$$

$$x = 41.8 \text{ (3 s.f.) or } 138 \text{ (3 s.f.)}$$

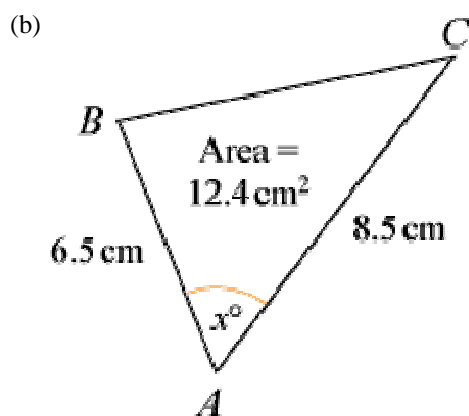

Using area = $\frac{1}{2}bc \sin A$

$$12.4 = \frac{1}{2} \times 8.5 \times 6.5 \times \sin x^\circ$$

$$\text{So } \sin x^\circ = \frac{12.4}{27.625} = 0.4488 \dots$$

$$x = 26.7 \text{ (3 s.f.) or } 153 \text{ (3 s.f.)}$$

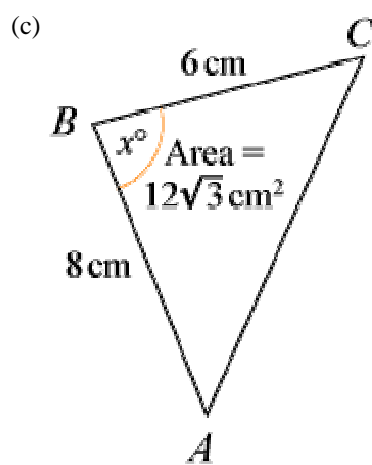

Using area = $\frac{1}{2}ac \sin B$

$$12\sqrt{3} = \frac{1}{2} \times 6 \times 8 \sin x^\circ$$

$$\text{So } \sin x^\circ = \frac{12\sqrt{3}}{24} = \frac{\sqrt{3}}{2}$$

$$x = 60 \text{ or } 120$$

© Pearson Education Ltd 2008

Solutionbank C2

Edexcel Modular Mathematics for AS and A-Level

The sine and cosine rule

Exercise G, Question 3

Question:

A fenced triangular plot of ground has area 1200 m^2 . The fences along the two smaller sides are 60 m and 80 m respectively and the angle between them is θ° . Show that $\theta = 150$, and work out the total length of fencing.

Solution:

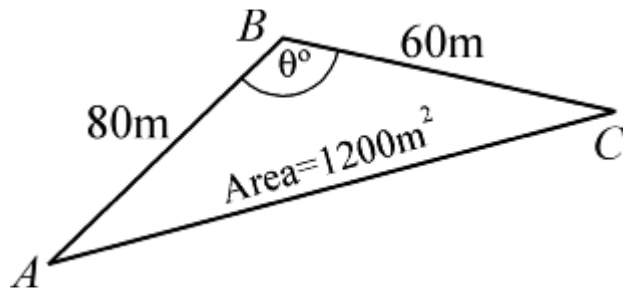

Using area = $\frac{1}{2}ac \sin B$

$$1200 = \frac{1}{2} \times 60 \times 80 \times \sin \theta^\circ$$

$$\sin \theta^\circ = \frac{1200}{2400} = \frac{1}{2}$$

$$\theta = 30 \text{ or } 150$$

but as AC is the largest side, θ must be the largest angle.

$$\text{So } \theta = 150$$

Using the cosine rule: $b^2 = a^2 + c^2 - 2ac \cos B$ to find AC

$$AC^2 = 60^2 + 80^2 - 2 \times 60 \times 80 \times \cos 150^\circ = 18313.84 \dots$$

$$AC = 135.3 \dots$$

$$AC = 135 \text{ m (3 s.f.)}$$

$$\text{So perimeter} = 60 + 80 + 135 = 275 \text{ m (3 s.f.)}$$

Solutionbank C2

Edexcel Modular Mathematics for AS and A-Level

The sine and cosine rule

Exercise G, Question 4

Question:

In triangle ABC , shown below, $BC = (x + 2)$ cm, $AC = x$ cm and $\angle BCA = 150^\circ$.

Given that the area of the triangle is 5 cm^2 , work out the value of x , giving your answer to 3 significant figures.

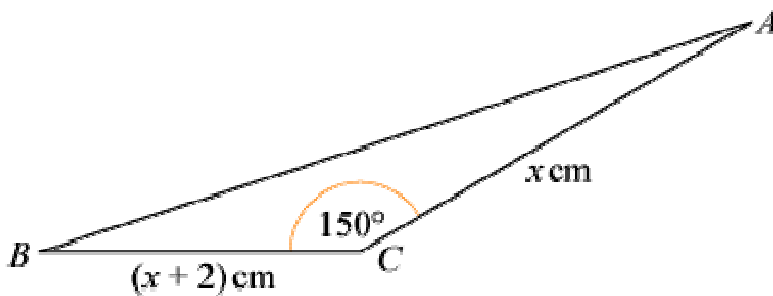

Solution:

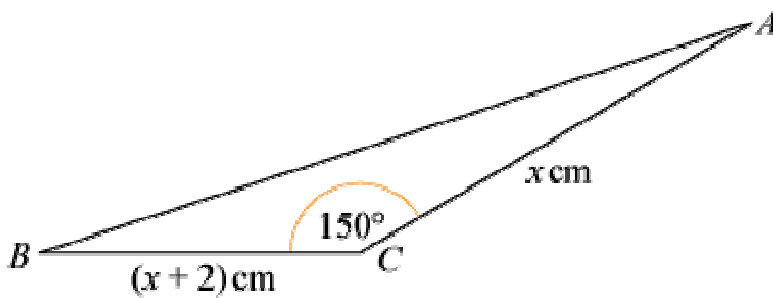

$$\text{Area of } \triangle ABC = \frac{1}{2}x \left(x + 2 \right) \sin 150^\circ \text{ cm}^2$$

$$\text{So } 5 = \frac{1}{2}x \left(x + 2 \right) \times \frac{1}{2}$$

$$\text{So } 20 = x(x + 2)$$

$$\text{or } x^2 + 2x - 20 = 0$$

$$\text{Using the quadratic equation formula } x = \frac{-b \pm \sqrt{b^2 - 4ac}}{2a}$$

$$x = \frac{-2 \pm \sqrt{84}}{2} = 3.582 \dots \quad \text{or} \quad -5.582 \dots$$

As $x > 0$, $x = 3.58$ (3 s.f.)

Solutionbank C2

Edexcel Modular Mathematics for AS and A-Level

The sine and cosine rule

Exercise G, Question 5

Question:

In $\triangle PQR$, $PQ = (x + 2)$ cm, $PR = (5 - x)$ cm and $\angle QPR = 30^\circ$.

The area of the triangle is A cm²:

(a) Show that $A = \frac{1}{4} (10 + 3x - x^2)$.

(b) Use the method of completing the square, or otherwise, to find the maximum value of A and give the corresponding value of x .

Solution:

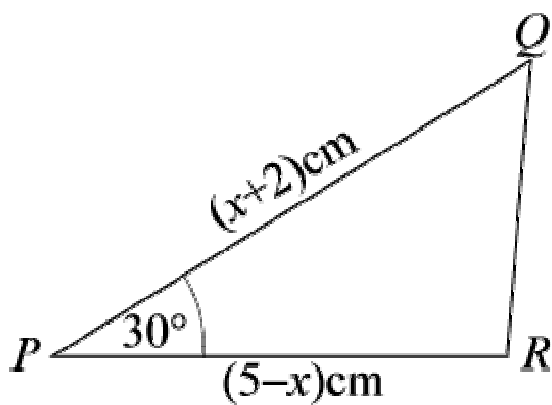

(a) Using area of $\triangle PQR = \frac{1}{2}qr \sin P$

$$A \text{ cm}^2 = \frac{1}{2} \left(5 - x \right) \left(x + 2 \right) \sin 30^\circ \text{ cm}^2$$

$$\Rightarrow A = \frac{1}{2} \left(5x - 2x + 10 - x^2 \right) \times \frac{1}{2}$$

$$\Rightarrow A = \frac{1}{4} \left(10 + 3x - x^2 \right)$$

(b) $10 + 3x - x^2$

$$= - (x^2 - 3x - 10)$$

$$= - \left[\left(x - 1 \frac{1}{2} \right)^2 - 2 \frac{1}{4} - 10 \right] \text{ (completing the square)}$$

$$= - \left[\left(x - 1 \frac{1}{2} \right)^2 - 12 \frac{1}{4} \right]$$

$$= 12 \frac{1}{4} - \left(x - 1 \frac{1}{2} \right)^2$$

The maximum value of $10 + 3x - x^2 = 12 \frac{1}{4}$, when $x = 1 \frac{1}{2}$.

The maximum value of A is $\frac{1}{4} \left(12 \frac{1}{4} \right) = 3 \frac{1}{16}$, when $x = 1 \frac{1}{2}$.

(You could find the maximum using differentiation.)

© Pearson Education Ltd 2008

Solutionbank C2

Edexcel Modular Mathematics for AS and A-Level

The sine and cosine rule

Exercise G, Question 6

Question:

In $\triangle ABC$, $AB = x$ cm, $AC = (5 + x)$ cm and $\angle BAC = 150^\circ$. Given that the area of the triangle is $3\frac{3}{4}$ cm²:

(a) Show that x satisfies the equation $x^2 + 5x - 15 = 0$.

(b) Calculate the value of x , giving your answer to 3 significant figures.

Solution:

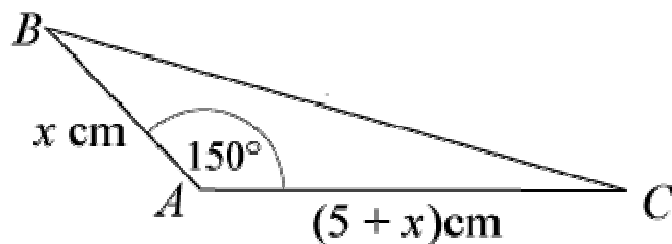

(a) Using area of $\triangle BAC = \frac{1}{2}bc \sin A$

$$3\frac{3}{4} \text{ cm}^2 = \frac{1}{2}x \left(5 + x \right) \sin 150^\circ \text{ cm}^2$$

$$3\frac{3}{4} = \frac{1}{2} \left[5x + x^2 \right] \times \frac{1}{2}$$

$$\Rightarrow 15 = 5x + x^2$$

$$\Rightarrow x^2 + 5x - 15 = 0$$

(b) Using the quadratic equation formula $x = \frac{-b \pm \sqrt{b^2 - 4ac}}{2a}$

$$x = \frac{-5 \pm \sqrt{85}}{2} = 2.109 \dots \quad \text{or} \quad -7.109 \dots$$

As $x > 0$, $x = 2.11$ (3 s.f.)

Solutionbank C2

Edexcel Modular Mathematics for AS and A-Level

The sine and cosine rule

Exercise H, Question 1

Question:

(Given non-exact answers to 3 significant figures.)

The area of a triangle is 10 cm^2 . The angle between two of the sides, of length 6 cm and 8 cm respectively, is obtuse. Work out:

- The size of this angle.
- The length of the third side.

Solution:

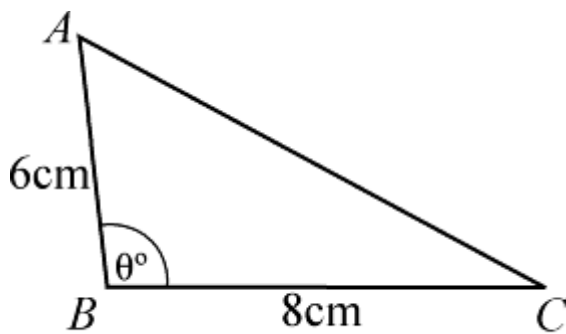

(a) Using area of $\triangle ABC = \frac{1}{2}ac \sin B$

$$10 \text{ cm}^2 = \frac{1}{2} \times 6 \times 8 \times \sin \theta^\circ \text{ cm}^2$$

$$\text{So } 10 = 24 \sin \theta^\circ$$

$$\text{So } \sin \theta^\circ = \frac{10}{24} = \frac{5}{12}$$

$$\Rightarrow \theta = 24.6 \text{ or } 155 \text{ (3 s.f.)}$$

As θ is obtuse, $\angle ABC = 155^\circ$ (3 s.f.)

(b) Using the cosine rule: $b^2 = a^2 + c^2 - 2ac \cos B$

$$AC^2 = 8^2 + 6^2 - 2 \times 8 \times 6 \times \cos B = 187.26 \dots$$

$$AC = 13.68 \dots$$

The third side has length 13.7m (3 s.f.)

Solutionbank C2

Edexcel Modular Mathematics for AS and A-Level

The sine and cosine rule

Exercise H, Question 2

Question:

(Give non-exact answers to 3 significant figures.)

In each triangle below, find the value of x and the area of the triangle:

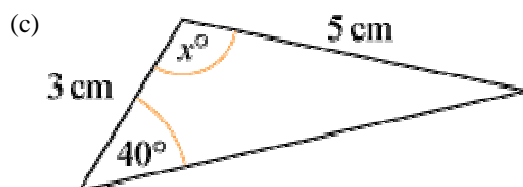
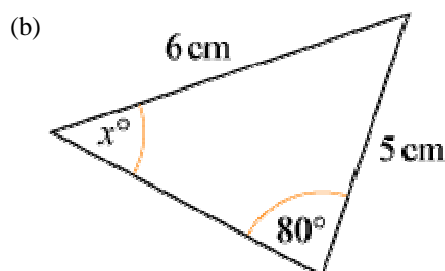
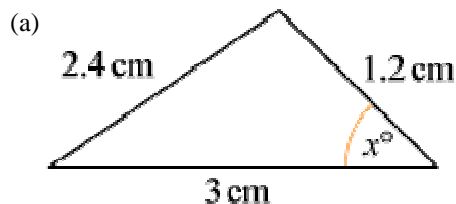

Solution:

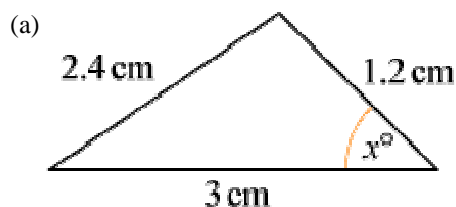

Using the cosine rule:

$$\cos x^\circ = \frac{3^2 + 1.2^2 - 2.4^2}{2 \times 3 \times 1.2} = 0.65$$

$$x = \cos^{-1}(0.65) = 49.458 \dots$$

$$x = 49.5 \text{ (3 s.f.)}$$

Using the area of a triangle formula:

$$\text{area} = \frac{1}{2} \times 1.2 \times 3 \times \sin x^\circ \text{ cm}^2 = 1.367 \dots \text{ cm}^2 = 1.37 \text{ cm}^2 \text{ (3 s.f.)}$$

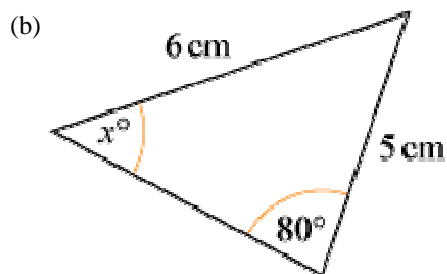

Using the sine rule:

$$\frac{\sin x^\circ}{5} = \frac{\sin 80^\circ}{6}$$

$$\sin x^\circ = \frac{5 \sin 80^\circ}{6} = 0.8206 \dots$$

$$x = 55.152 \dots$$

$$x = 55.2 \text{ (3 s.f.)}$$

The angle between 5 cm and 6 cm sides is $180^\circ - (80 + x)^\circ = (100 - x)^\circ$.

Using the area of a triangle formula:

$$\text{area} = \frac{1}{2} \times 5 \times 6 \times \sin \left(100 - x \right)^\circ \text{ cm}^2 = 10.6 \text{ cm}^2 \text{ (3 s.f.)}$$

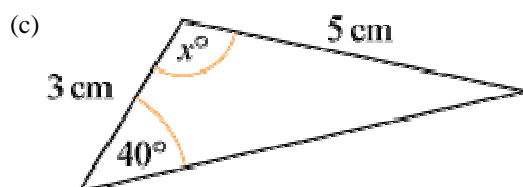

Using the sine rule to find angle opposite 3 cm. Call this y° .

$$\frac{\sin y^\circ}{3} = \frac{\sin 40^\circ}{5}$$

$$\sin y^\circ = \frac{3 \sin 40^\circ}{5}$$

$$\Rightarrow y = 22.68 \dots$$

$$\text{So } x = 180 - (40 + y) = 117.3 \dots = 117 \text{ (3 s.f.)}$$

$$\text{Area of triangle} = \frac{1}{2} \times 3 \times 5 \times \sin x^\circ = 6.66 \text{ cm}^2 \text{ (3 s.f.)}$$

Solutionbank C2

Edexcel Modular Mathematics for AS and A-Level

The sine and cosine rule

Exercise H, Question 3

Question:

(Give non-exact answers to 3 significant figures.)

The sides of a triangle are 3 cm, 5 cm and 7 cm respectively. Show that the largest angle is 120° , and find the area of the triangle.

Solution:

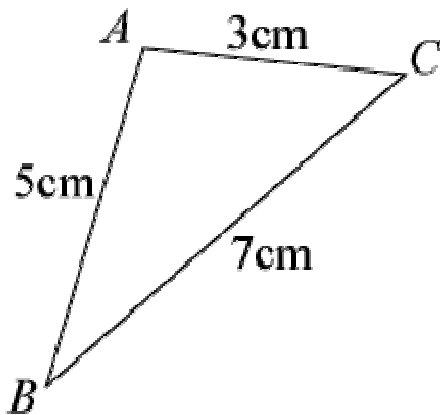

Using cosine rule to find angle A

$$\cos A = \frac{3^2 + 5^2 - 7^2}{2 \times 3 \times 5} = -0.5$$

$$A = \cos^{-1}(-0.5) = 120^\circ$$

$$\text{Area of triangle} = \frac{1}{2} \times 3 \times 5 \times \sin A \text{ cm}^2 = 6.495 \dots \text{ cm}^2 = 6.50 \text{ cm}^2 \text{ (3 s.f.)}$$

Solutionbank C2

Edexcel Modular Mathematics for AS and A-Level

The sine and cosine rule

Exercise H, Question 4

Question:

(Give non-exact answers to 3 significant figures.)

In each of the figures below calculate the total area:

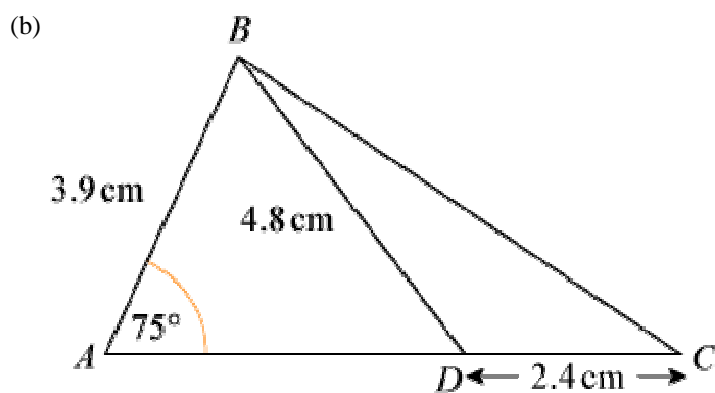
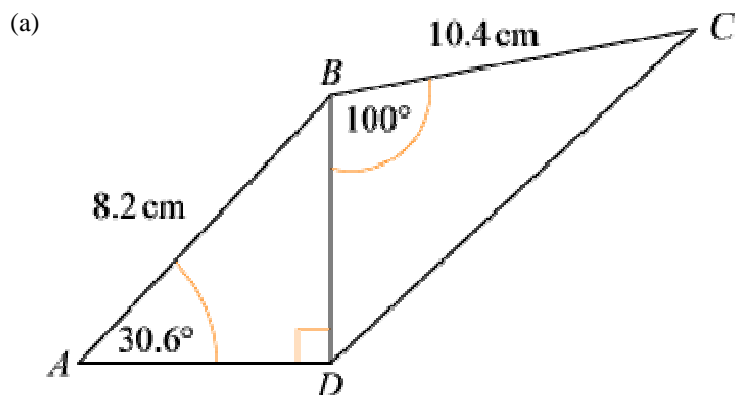

Solution:

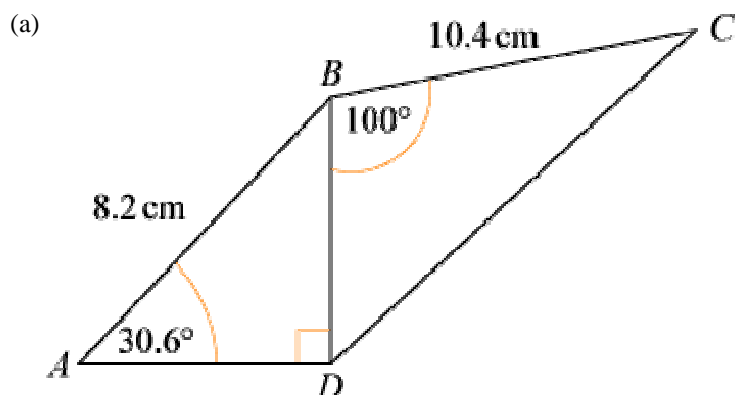

$$\text{In } \triangle BDA: \frac{BD}{8.2} = \sin 30.6^\circ$$

$$\Rightarrow BD = 8.2 \sin 30.6^\circ = 4.174 \dots$$

$$\text{Angle } ABD = 90^\circ - 30.6^\circ = 59.4^\circ$$

$$\text{Area of } \triangle ABD = \frac{1}{2} \times 8.2 \times BD \times \sin 59.4^\circ = 14.7307 \dots \text{ cm}^2$$

$$\text{Area of } \triangle BDC = \frac{1}{2} \times 10.4 \times BD \times \sin 100^\circ = 21.375 \dots \text{ cm}^2$$

$$\text{Total area} = \text{area of } \triangle ABD + \text{area } \triangle BDC = 36.1 \text{ cm}^2 \text{ (3 s.f.)}$$

(b)

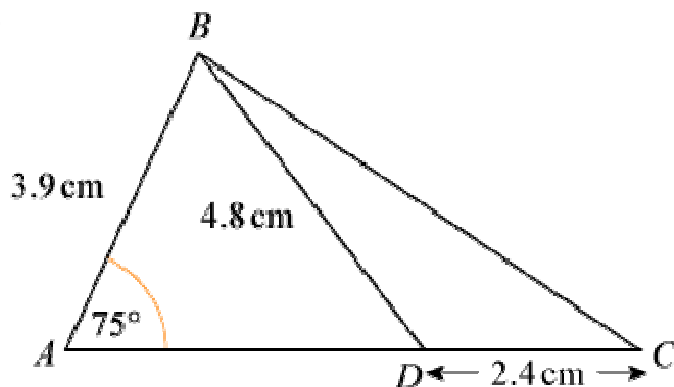

In $\triangle ABD$, using the sine rule to find $\angle ADB$,

$$\frac{\sin \angle ADB}{3.9} = \frac{\sin 75^\circ}{4.8}$$

$$\sin \angle ADB = \frac{3.9 \sin 75^\circ}{4.8}$$

$$\angle ADB = \sin^{-1} \left(\frac{3.9 \sin 75^\circ}{4.8} \right) = 51.7035 \dots^\circ$$

$$\text{So } \angle ABD = 180^\circ - (75^\circ + \angle ADB)^\circ = 53.296 \dots^\circ$$

$$\text{Area of } \triangle ABD = \frac{1}{2} \times 3.9 \times 4.8 \times \sin \angle ABD \text{ cm}^2 = 7.504 \dots \text{ cm}^2$$

$$\text{In } \triangle BDC, \angle BDC = 180^\circ - \angle BDA = 128.29 \dots^\circ$$

$$\text{Area of } \triangle BDC = \frac{1}{2} \times 2.4 \times 4.8 \times \sin \angle BDC \text{ cm}^2 = 4.520 \dots \text{ cm}^2$$

$$\text{Total area} = \text{area of } \triangle ABD + \text{area of } \triangle BDC = 12.0 \text{ cm}^2 \text{ (3 s.f.)}$$

© Pearson Education Ltd 2008

Solutionbank C2

Edexcel Modular Mathematics for AS and A-Level

The sine and cosine rule

Exercise H, Question 5

Question:

(Give non-exact answers to 3 significant figures.)

In $\triangle ABC$, $AB = 10$ cm, $BC = a\sqrt{3}$ cm, $AC = 5\sqrt{13}$ cm and $\angle ABC = 150^\circ$. Calculate:

- The value of a .
- The exact area of $\triangle ABC$.

Solution:

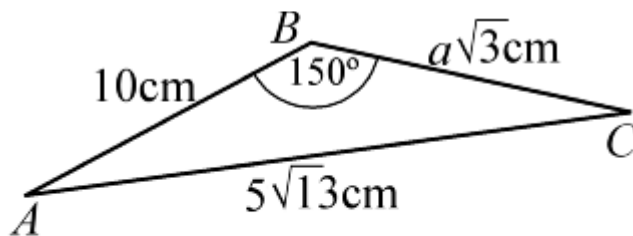

(a) Using the cosine rule: $b^2 = a^2 + c^2 - 2ac \cos B$
 $(5\sqrt{13})^2 = (a\sqrt{3})^2 + 10^2 - 2 \times a\sqrt{3} \times 10 \times \cos 150^\circ$
 $325 = 3a^2 + 100 + 30a$
 $3a^2 + 30a - 225 = 0$
 $a^2 + 10a - 75 = 0$
 $(a + 15)(a - 5) = 0$
 $\Rightarrow a = 5$ as $a > 0$

(b) Area of $\triangle ABC = \frac{1}{2} \times 10 \times 5\sqrt{3} \times \sin 150^\circ \text{ cm}^2 = 12.5\sqrt{3} \text{ cm}^2$

Solutionbank C2

Edexcel Modular Mathematics for AS and A-Level

The sine and cosine rule

Exercise H, Question 6

Question:

(Give non-exact answers to 3 significant figures.)

In a triangle, the largest side has length 2 cm and one of the other sides has length $\sqrt{2}$ cm. Given that the area of the triangle is 1 cm^2 , show that the triangle is right-angled and isosceles.

Solution:

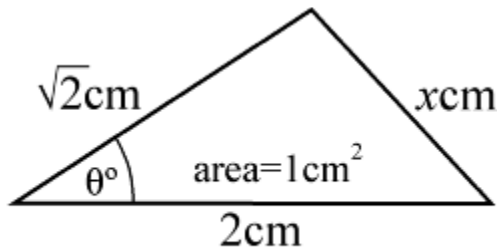

Using the area formula:

$$1 = \frac{1}{2} \times 2 \times \sqrt{2} \times \sin \theta^\circ$$

$$\Rightarrow \sin \theta^\circ = \frac{1}{\sqrt{2}}$$

$$\Rightarrow \theta = 45 \text{ or } 135$$

but as θ is not the largest angle, θ must be 45.

Using the cosine rule to find x :

$$x^2 = 2^2 + (\sqrt{2})^2 - 2 \times 2 \times \sqrt{2} \times \cos 45^\circ$$

$$x^2 = 4 + 2 - 4 = 2$$

$$\text{So } x = \sqrt{2}$$

So the triangle is isosceles with two angles of 45° .

It is a right-angled isosceles triangle.

Solutionbank C2

Edexcel Modular Mathematics for AS and A-Level

The sine and cosine rule

Exercise H, Question 7

Question:

(Give non-exact answers to 3 significant figures.)

The three points A , B and C , with coordinates $A(0, 1)$, $B(3, 4)$ and $C(1, 3)$ respectively, are joined to form a triangle:

(a) Show that $\cos \angle ACB = -\frac{4}{5}$.

(b) Calculate the area of $\triangle ABC$.

Solution:

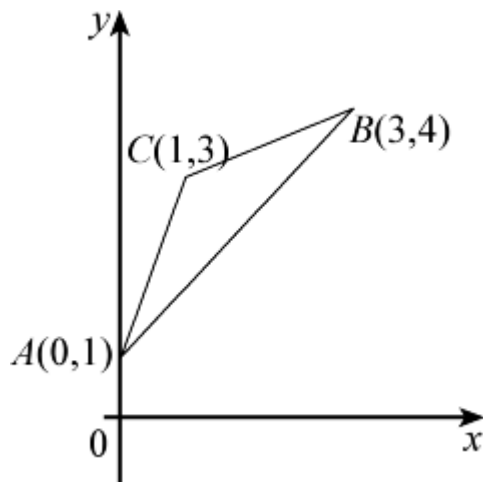

$$(a) AC = \sqrt{(1-0)^2 + (3-1)^2} = \sqrt{5} = b$$

$$BC = \sqrt{(3-1)^2 + (4-3)^2} = \sqrt{5} = a$$

$$AB = \sqrt{(3-0)^2 + (4-1)^2} = \sqrt{18} = c$$

$$\text{Using the cosine rule: } \cos C = \frac{a^2 + b^2 - c^2}{2ab}$$

$$\cos C = \frac{5 + 5 - 18}{2 \times \sqrt{5} \times \sqrt{5}} = \frac{-8}{10} = -\frac{4}{5}$$

(b) Using the area formula:

$$\text{area of } \triangle ABC = \frac{1}{2} ab \sin C = \frac{1}{2} \times \sqrt{5} \times \sqrt{5} \times \sin C = 1.5 \text{ cm}^2$$

Solutionbank C2

Edexcel Modular Mathematics for AS and A-Level

The sine and cosine rule

Exercise H, Question 8

Question:

(Give non-exact answers to 3 significant figures.)

The longest side of a triangle has length $(2x - 1)$ cm. The other sides have lengths $(x - 1)$ cm and $(x + 1)$ cm. Given that the largest angle is 120° , work out:

(a) the value of x and (b) the area of the triangle.

Solution:

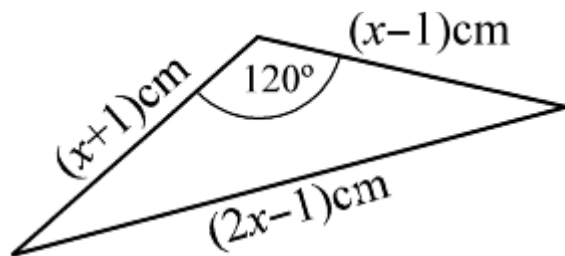

(a) Using the cosine rule:

$$(2x - 1)^2 = (x + 1)^2 + (x - 1)^2 - 2(x + 1)(x - 1) \cos 120^\circ$$

$$4x^2 - 4x + 1 = (x^2 + 2x + 1) + (x^2 - 2x + 1) + (x^2 - 1)$$

$$4x^2 - 4x + 1 = 3x^2 + 1$$

$$x^2 - 4x = 0$$

$$x(x - 4) = 0$$

$$\Rightarrow x = 4 \text{ as } x > 1$$

(b) Area of triangle

$$= \frac{1}{2} \times \left(x + 1 \right) \times \left(x - 1 \right) \times \sin 120^\circ \text{ cm}^2$$

$$= \frac{1}{2} \times 5 \times 3 \times \sin 120^\circ \text{ cm}^2$$

$$= \frac{1}{2} \times 5 \times 3 \times \frac{\sqrt{3}}{2} \text{ cm}^2$$

$$= \frac{15\sqrt{3}}{4} \text{ cm}^2$$

$$= 6.50 \text{ cm}^2 \text{ (3 s.f.)}$$

Solutionbank C2

Edexcel Modular Mathematics for AS and A-Level

Exponentials and logarithms

Exercise A, Question 1

Question:

- (a) Draw an accurate graph of $y = (1.7)^x$, for $-4 \leq x \leq 4$.
- (b) Use your graph to solve the equation $(1.7)^x = 4$.

Solution:

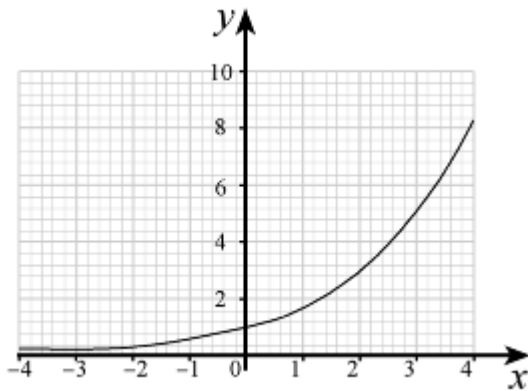

(a)

(b) Where $y = 4$, $x \approx 2.6$

© Pearson Education Ltd 2008

Solutionbank C2

Edexcel Modular Mathematics for AS and A-Level

Exponentials and logarithms

Exercise A, Question 2

Question:

- (a) Draw an accurate graph of $y = (0.6)^x$, for $-4 \leq x \leq 4$.
- (b) Use your graph to solve the equation $(0.6)^x = 2$.

Solution:

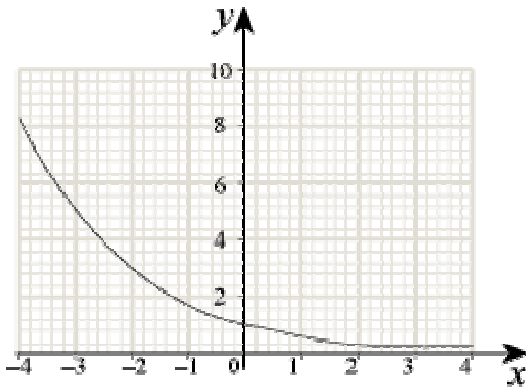

(a)

- (b) Where $y = 2$, $x \approx -1.4$

© Pearson Education Ltd 2008

Solutionbank C2

Edexcel Modular Mathematics for AS and A-Level

Exponentials and logarithms

Exercise A, Question 3

Question:

Sketch the graph of $y = 1^x$.

Solution:

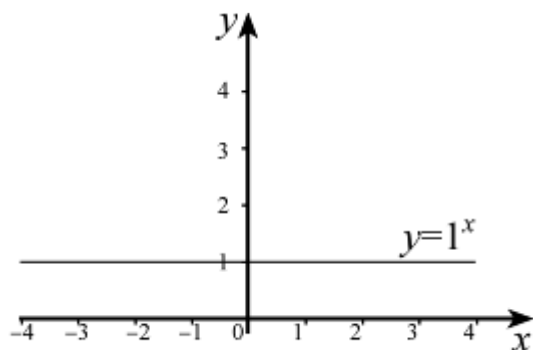

Solutionbank C2

Edexcel Modular Mathematics for AS and A-Level

Exponentials and logarithms

Exercise B, Question 1

Question:

Rewrite as a logarithm:

(a) $4^4 = 256$

(b) $3^{-2} = \frac{1}{9}$

(c) $10^6 = 1\ 000\ 000$

(d) $11^1 = 11$

(e) $(0.2)^3 = 0.008$

Solution:

(a) $\log_4 256 = 4$

(b) $\log_3 \left(\frac{1}{9} \right) = -2$

(c) $\log_{10} 1\ 000\ 000 = 6$

(d) $\log_{11} 11 = 1$

(e) $\log_{0.2} 0.008 = 3$

Solutionbank C2

Edexcel Modular Mathematics for AS and A-Level

Exponentials and logarithms

Exercise B, Question 2

Question:

Rewrite using a power:

(a) $\log_2 16 = 4$

(b) $\log_5 25 = 2$

(c) $\log_9 3 = \frac{1}{2}$

(d) $\log_5 0.2 = -1$

(e) $\log_{10} 100\,000 = 5$

Solution:

(a) $2^4 = 16$

(b) $5^2 = 25$

(c) $9^{\frac{1}{2}} = 3$

(d) $5^{-1} = 0.2$

(e) $10^5 = 100\,000$

© Pearson Education Ltd 2008

Solutionbank C2

Edexcel Modular Mathematics for AS and A-Level

Exponentials and logarithms

Exercise B, Question 3

Question:

Find the value of:

(a) $\log_2 8$

(b) $\log_5 25$

(c) $\log_{10} 10\,000\,000$

(d) $\log_{12} 12$

(e) $\log_3 729$

(f) $\log_{10} \sqrt{10}$

(g) $\log_4 (0.25)$

(h) $\log_{0.25} 16$

(i) $\log_a (a^{10})$

(j) $\log \left(\frac{2}{3} \right) \left(\frac{9}{4} \right)$

Solution:

(a) If $\log_2 8 = x$ then $2^x = 8$, so $x = 3$

(b) If $\log_5 25 = x$ then $5^x = 25$, so $x = 2$

(c) If $\log_{10} 10\,000\,000 = x$ then $10^x = 10\,000\,000$, so $x = 7$

(d) If $\log_{12} 12 = x$ then $12^x = 12$, so $x = 1$

(e) If $\log_3 729 = x$ then $3^x = 729$, so $x = 6$

(f) If $\log_{10} \sqrt{10} = x$ then $10^x = \sqrt{10}$, so $x = \frac{1}{2}$

(Power $\frac{1}{2}$ means 'square root'.)

(g) If $\log_4 (0.25) = x$ then $4^x = 0.25 = \frac{1}{4}$, so $x = -1$

(Negative power means 'reciprocal'.)

$$(h) \log_{0.25} 16 = x$$

$$\Rightarrow 0.25^x = 16$$

$$\Rightarrow \left(\frac{1}{4}\right)^x = 16, \text{ so } x = -2$$

$$\left[\left(\frac{1}{4}\right)^{-2} = \frac{1}{\left(\frac{1}{4}\right)^2} = \frac{1}{\left(\frac{1}{16}\right)} = 16 \right]$$

$$(i) \log_a (a^{10}) = x$$

$$\Rightarrow a^x = a^{10}, \text{ so } x = 10$$

$$(j) \log \left(\frac{2}{3}\right) \left(\frac{9}{4}\right) = x$$

$$\Rightarrow \left(\frac{2}{3}\right)^x = \frac{9}{4}, \text{ so } x = -2$$

$$\left[\left(\frac{2}{3}\right)^{-2} = \frac{1}{\left(\frac{2}{3}\right)^2} = \frac{1}{\left(\frac{4}{9}\right)} = \frac{9}{4} \right]$$

Solutionbank C2

Edexcel Modular Mathematics for AS and A-Level

Exponentials and logarithms

Exercise B, Question 4

Question:

Find the value of x for which:

(a) $\log_5 x = 4$

(b) $\log_x 81 = 2$

(c) $\log_7 x = 1$

(d) $\log_x (2x) = 2$

Solution:

(a) Using a power, $5^4 = x$
So $x = 625$

(b) Using a power, $x^2 = 81$
So $x = 9$
(The base of a logarithm cannot be negative, so $x = -9$ is not possible.)

(c) Using a power, $7^1 = x$
So $x = 7$

(d) Using a power,
 $x^2 = 2x$
 $x^2 - 2x = 0$
 $x(x - 2) = 0$
 $x = 2$
(The base of a logarithm cannot be zero, so $x = 0$ is not possible.)

Solutionbank C2

Edexcel Modular Mathematics for AS and A-Level

Exponentials and logarithms

Exercise C, Question 1

Question:

Find from your calculator the value to 3 s.f. of:

$$\log_{10} 20$$

Solution:

$$\log_{10} 20 = 1.3010 \dots = 1.30 \text{ (3 s.f.)}$$

© Pearson Education Ltd 2008

Solutionbank C2

Edexcel Modular Mathematics for AS and A-Level

Exponentials and logarithms

Exercise C, Question 2

Question:

Find from your calculator the value to 3 s.f. of:
 $\log_{10} 4$

Solution:

$$\log_{10} 4 = 0.6020 \dots = 0.602 \text{ (3 s.f.)}$$

© Pearson Education Ltd 2008

Solutionbank C2

Edexcel Modular Mathematics for AS and A-Level

Exponentials and logarithms

Exercise C, Question 3

Question:

Find from your calculator the value to 3 s.f. of:
 $\log_{10} 7000$

Solution:

$$\log_{10} 7000 = 3.8450 \dots = 3.85 \text{ (3 s.f.)}$$

© Pearson Education Ltd 2008

Solutionbank C2

Edexcel Modular Mathematics for AS and A-Level

Exponentials and logarithms

Exercise C, Question 4

Question:

Find from your calculator the value to 3 s.f. of:

$$\log_{10} 0.786$$

Solution:

$$\log_{10} 0.786 = -0.1045 \dots = -0.105 \text{ (3 s.f.)}$$

© Pearson Education Ltd 2008

Solutionbank C2

Edexcel Modular Mathematics for AS and A-Level

Exponentials and logarithms

Exercise C, Question 5

Question:

Find from your calculator the value to 3 s.f. of:

$$\log_{10} 11$$

Solution:

$$\log_{10} 11 = 1.0413 \dots = 1.04 \text{ (3 s.f.)}$$

© Pearson Education Ltd 2008

Solutionbank C2

Edexcel Modular Mathematics for AS and A-Level

Exponentials and logarithms

Exercise C, Question 6

Question:

Find from your calculator the value to 3 s.f. of:
 $\log_{10} 35.3$

Solution:

$$\log_{10} 35.3 = 1.5477 \dots = 1.55 \text{ (3 s.f.)}$$

© Pearson Education Ltd 2008

Solutionbank C2

Edexcel Modular Mathematics for AS and A-Level

Exponentials and logarithms

Exercise C, Question 7

Question:

Find from your calculator the value to 3 s.f. of:
 $\log_{10} 0.3$

Solution:

$$\log_{10} 0.3 = -0.5228 \dots = -0.523 \text{ (3 s.f.)}$$

© Pearson Education Ltd 2008

Solutionbank C2

Edexcel Modular Mathematics for AS and A-Level

Exponentials and logarithms

Exercise C, Question 8

Question:

Find from your calculator the value to 3 s.f. of:
 $\log_{10} 999$

Solution:

$$\log_{10} 999 = 2.9995 \dots = 3.00 \text{ (3 s.f.)}$$

© Pearson Education Ltd 2008

Solutionbank C2

Edexcel Modular Mathematics for AS and A-Level

Exponentials and logarithms

Exercise D, Question 1

Question:

Write as a single logarithm:

(a) $\log_2 7 + \log_2 3$

(b) $\log_2 36 - \log_2 4$

(c) $3 \log_5 2 + \log_5 10$

(d) $2 \log_6 8 - 4 \log_6 3$

(e) $\log_{10} 5 + \log_{10} 6 - \log_{10} \left(\frac{1}{4} \right)$

Solution:

(a) $\log_2 (7 \times 3) = \log_2 21$

(b) $\log_2 \left(\frac{36}{4} \right) = \log_2 9$

(c) $3 \log_5 2 = \log_5 2^3 = \log_5 8$
 $\log_5 8 + \log_5 10 = \log_5 (8 \times 10) = \log_5 80$

(d) $2 \log_6 8 = \log_6 8^2 = \log_6 64$
 $4 \log_6 3 = \log_6 3^4 = \log_6 81$

$\log_6 64 - \log_6 81 = \log_6 \left(\frac{64}{81} \right)$

(e) $\log_{10} 5 + \log_{10} 6 = \log_{10} (5 \times 6) = \log_{10} 30$

$\log_{10} 30 - \log_{10} \left(\frac{1}{4} \right) = \log_{10} \left[\frac{30}{\left(\frac{1}{4} \right)} \right] = \log_{10} 120$

Solutionbank C2

Edexcel Modular Mathematics for AS and A-Level

Exponentials and logarithms

Exercise D, Question 2

Question:

Write as a single logarithm, then simplify your answer:

(a) $\log_2 40 - \log_2 5$

(b) $\log_6 4 + \log_6 9$

(c) $2 \log_{12} 3 + 4 \log_{12} 2$

(d) $\log_8 25 + \log_8 10 - 3 \log_8 5$

(e) $2 \log_{10} 20 - (\log_{10} 5 + \log_{10} 8)$

Solution:

(a) $\log_2 \left(\frac{40}{5} \right) = \log_2 8 = 3 \quad \left(2^3 = 8 \right)$

(b) $\log_6 (4 \times 9) = \log_6 36 = 2 \quad (6^2 = 36)$

(c) $\log_{12} (3^2) + \log_{12} (2^4)$
 $= \log_{12} 9 + \log_{12} 16$
 $= \log_{12} (9 \times 16)$
 $= \log_{12} 144$
 $= 2 \quad (12^2 = 144)$

(d) $\log_8 (25 \times 10) - \log_8 (5^3)$
 $= \log_8 250 - \log_8 125$
 $= \log_8 \left(\frac{250}{125} \right)$
 $= \log_8 2$
 $= \frac{1}{3} \quad \left(8^{\frac{1}{3}} = 2 \right)$

(e) $\log_{10} (20^2) - \log_{10} (5 \times 8)$
 $= \log_{10} 400 - \log_{10} 40$
 $= \log_{10} \left(\frac{400}{40} \right)$
 $= \log_{10} 10$
 $= 1 \quad (10^1 = 10)$

Solutionbank C2

Edexcel Modular Mathematics for AS and A-Level

Exponentials and logarithms

Exercise D, Question 3

Question:

Write in terms of $\log_a x$, $\log_a y$ and $\log_a z$:

(a) $\log_a (x^3y^4z)$

(b) $\log_a \left(\frac{x^5}{y^2} \right)$

(c) $\log_a (a^2x^2)$

(d) $\log_a \left(\frac{x\sqrt{y}}{z} \right)$

(e) $\log_a \sqrt{ax}$

Solution:

(a) $\log_a x^3 + \log_a y^4 + \log_a z$
 $= 3 \log_a x + 4 \log_a y + \log_a z$

(b) $\log_a x^5 - \log_a y^2$
 $= 5 \log_a x - 2 \log_a y$

(c) $\log_a a^2 + \log_a x^2$
 $= 2 \log_a a + 2 \log_a x$
 $= 2 + 2 \log_a x \quad (\log_a a = 1)$

(d) $\log_a x + \log_a y^{\frac{1}{2}} - \log_a z$
 $= \log_a x + \frac{1}{2} \log_a y - \log_a z$

(e) $\log_a (ax)^{\frac{1}{2}}$
 $= \frac{1}{2} \log_a (ax)$
 $= \frac{1}{2} \log_a a + \frac{1}{2} \log_a x$
 $= \frac{1}{2} + \frac{1}{2} \log_a x$

Solutionbank C2

Edexcel Modular Mathematics for AS and A-Level

Exponentials and logarithms

Exercise E, Question 1

Question:

Solve, giving your answer to 3 significant figures:

(a) $2^x = 75$

(b) $3^x = 10$

(c) $5^x = 2$

(d) $4^{2x} = 100$

(e) $9^{x+5} = 50$

(f) $7^{2x-1} = 23$

(g) $3^{x-1} = 8^{x+1}$

(h) $2^{2x+3} = 3^{3x+2}$

(i) $8^{3-x} = 10^x$

(j) $3^{4-3x} = 4^{x+5}$

Solution:

(a) $2^x = 75$

$$\log 2^x = \log 75$$

$$x \log 2 = \log 75$$

$$x = \frac{\log 75}{\log 2}$$

$$x = 6.23 \text{ (3 s.f.)}$$

(b) $3^x = 10$

$$\log 3^x = \log 10$$

$$x \log 3 = \log 10$$

$$x = \frac{\log 10}{\log 3}$$

$$x = 2.10 \text{ (3 s.f.)}$$

(c) $5^x = 2$

$$\log 5^x = \log 2$$

$$x \log 5 = \log 2$$

$$x = \frac{\log 2}{\log 5}$$

$$x = 0.431 \text{ (3 s.f.)}$$

(d) $4^{2x} = 100$

$$\log 4^{2x} = \log 100$$

$$2x \log 4 = \log 100$$

$$x = \frac{\log 100}{2 \log 4}$$

$$x = 1.66 \text{ (3 s.f.)}$$

$$(e) 9^{x+5} = 50$$

$$\log 9^{x+5} = \log 50$$

$$(x+5) \log 9 = \log 50$$

$$x \log 9 + 5 \log 9 = \log 50$$

$$x \log 9 = \log 50 - 5 \log 9$$

$$x = \frac{\log 50 - 5 \log 9}{\log 9}$$

$$x = -3.22 \text{ (3 s.f.)}$$

$$(f) 7^{2x-1} = 23$$

$$\log 7^{2x-1} = \log 23$$

$$(2x-1) \log 7 = \log 23$$

$$2x \log 7 - \log 7 = \log 23$$

$$2x \log 7 = \log 23 + \log 7$$

$$x = \frac{\log 23 + \log 7}{2 \log 7}$$

$$x = 1.31 \text{ (3 s.f.)}$$

$$(g) 3^{x-1} = 8^{x+1}$$

$$\log 3^{x-1} = \log 8^{x+1}$$

$$(x-1) \log 3 = (x+1) \log 8$$

$$x \log 3 - \log 3 = x \log 8 + \log 8$$

$$x(\log 3 - \log 8) = \log 3 + \log 8$$

$$x = \frac{\log 3 + \log 8}{\log 3 - \log 8}$$

$$x = -3.24 \text{ (3 s.f.)}$$

$$(h) 2^{2x+3} = 3^{3x+2}$$

$$\log 2^{2x+3} = \log 3^{3x+2}$$

$$(2x+3) \log 2 = (3x+2) \log 3$$

$$2x \log 2 + 3 \log 2 = 3x \log 3 + 2 \log 3$$

$$2x \log 2 - 3x \log 3 = 2 \log 3 - 3 \log 2$$

$$x(2 \log 2 - 3 \log 3) = 2 \log 3 - 3 \log 2$$

$$x = \frac{2 \log 3 - 3 \log 2}{2 \log 2 - 3 \log 3}$$

$$x = -0.0617 \text{ (3 s.f.)}$$

$$(i) 8^{3-x} = 10^x$$

$$\log 8^{3-x} = \log 10^x$$

$$(3-x) \log 8 = x \log 10$$

$$3 \log 8 - x \log 8 = x \log 10$$

$$3 \log 8 = x(\log 10 + \log 8)$$

$$x = \frac{3 \log 8}{\log 10 + \log 8}$$

$$x = 1.42 \text{ (3 s.f.)}$$

$$(j) 3^{4-3x} = 4^{x+5}$$

$$\log 3^{4-3x} = \log 4^{x+5}$$

$$(4-3x) \log 3 = (x+5) \log 4$$

$$4 \log 3 - 3x \log 3 = x \log 4 + 5 \log 4$$

$$4 \log 3 - 5 \log 4 = x \log 4 + 3x \log 3$$

$$4 \log 3 - 5 \log 4 = x(\log 4 + 3 \log 3)$$

$$x = \frac{4 \log 3 - 5 \log 4}{\log 4 + 3 \log 3}$$

$$x = -0.542 \text{ (3 s.f.)}$$

© Pearson Education Ltd 2008

Solutionbank C2

Edexcel Modular Mathematics for AS and A-Level

Exponentials and logarithms

Exercise E, Question 2

Question:

Solve, giving your answer to 3 significant figures:

(a) $2^{2x} - 6(2^x) + 5 = 0$

(b) $3^{2x} - 15(3^x) + 44 = 0$

(c) $5^{2x} - 6(5^x) - 7 = 0$

(d) $3^{2x} + 3^{x+1} - 10 = 0$

(e) $7^{2x} + 12 = 7^{x+1}$

(f) $2^{2x} + 3(2^x) - 4 = 0$

(g) $3^{2x+1} - 26(3^x) - 9 = 0$

(h) $4(3^{2x+1}) + 17(3^x) - 7 = 0$

Solution:

(a) Let $y = 2^x$

$$y^2 - 6y + 5 = 0$$

$$(y - 1)(y - 5) = 0$$

So $y = 1$ or $y = 5$

If $y = 1$, $2^x = 1$, $x = 0$

If $y = 5$, $2^x = 5$

$$\log 2^x = \log 5$$

$$x \log 2 = \log 5$$

$$x = \frac{\log 5}{\log 2}$$

$$x = 2.32 \text{ (3 s.f.)}$$

So $x = 0$ or $x = 2.32$

(b) Let $y = 3^x$

$$y^2 - 15y + 44 = 0$$

$$(y - 4)(y - 11) = 0$$

So $y = 4$ or $y = 11$

If $y = 4$, $3^x = 4$

$$\log 3^x = \log 4$$

$$x \log 3 = \log 4$$

$$x = \frac{\log 4}{\log 3}$$

$$x = 1.26 \text{ (3 s.f.)}$$

If $y = 11$, $3^x = 11$

$$\log 3^x = \log 11$$

$$x \log 3 = \log 11$$

$$x = \frac{\log 11}{\log 3}$$

$$x = 2.18 \text{ (3 s.f.)}$$

So $x = 1.26$ or $x = 2.18$

(c) Let $y = 5^x$

$$y^2 - 6y - 7 = 0$$

$$(y + 1)(y - 7) = 0$$

$$\text{So } y = -1 \text{ or } y = 7$$

If $y = -1$, $5^x = -1$. No solution.

$$\text{If } y = 7, 5^x = 7$$

$$\log 5^x = \log 7$$

$$x \log 5 = \log 7$$

$$x = \frac{\log 7}{\log 5}$$

$$x = 1.21 \text{ (3 s.f.)}$$

(d) Let $y = 3^x$

$$(3^x)^2 + (3^x \times 3) - 10 = 0$$

$$y^2 + 3y - 10 = 0$$

$$(y + 5)(y - 2) = 0$$

$$\text{So } y = -5 \text{ or } y = 2$$

If $y = -5$, $3^x = -5$. No solution.

$$\text{If } y = 2, 3^x = 2$$

$$\log 3^x = \log 2$$

$$x \log 3 = \log 2$$

$$x = \frac{\log 2}{\log 3}$$

$$x = 0.631 \text{ (3 s.f.)}$$

(e) Let $y = 7^x$

$$(7^x)^2 + 12 = 7^x \times 7$$

$$y^2 + 12 = 7y$$

$$y^2 - 7y + 12 = 0$$

$$(y - 3)(y - 4) = 0$$

$$\text{So } y = 3 \text{ or } y = 4$$

$$\text{If } y = 3, 7^x = 3$$

$$x \log 7 = \log 3$$

$$x = \frac{\log 3}{\log 7}$$

$$x = 0.565 \text{ (3 s.f.)}$$

$$\text{If } y = 4, 7^x = 4$$

$$x \log 7 = \log 4$$

$$x = \frac{\log 4}{\log 7}$$

$$x = 0.712 \text{ (3 s.f.)}$$

$$\text{So } x = 0.565 \text{ or } x = 0.712$$

$$(f) 2^{2x} + 3(2^x) - 4 = 0$$

$$\text{Let } y = 2^x$$

$$\text{Then } y^2 + 3y - 4 = 0$$

$$\text{So } (y + 4)(y - 1) = 0$$

$$\text{So } y = -4 \text{ or } y = 1$$

$$2^x = -4 \text{ has no solution}$$

$$\text{Therefore } 2^x = 1$$

$$\text{So } x = 0 \text{ is the only solution}$$

$$(g) 3^{2x+1} - 26(3^x) - 9 = 0$$

$$\text{Let } y = 3^x$$

$$\text{Then } 3y^2 - 26y - 9 = 0$$

$$\text{So } (3y + 1)(y - 9) = 0$$

$$\text{So } y = -\frac{1}{3} \text{ or } y = 9$$

$$3^x = -\frac{1}{3} \text{ has no solution}$$

$$\text{Therefore } 3^x = 9$$

So $x = 2$ is the only solution

$$\text{(h) } 4(3^{2x+1}) + 17(3^x) - 7 = 0$$

$$12(3^{2x}) + 17(3^x) - 7 = 0$$

$$\text{Let } y = 3^x$$

$$\text{So } 12y^2 + 17y - 7 = 0$$

$$\text{So } (3y - 1)(4y + 7) = 0$$

$$\text{So } y = \frac{1}{3} \text{ or } y = -\frac{7}{4}$$

$$3^x = -\frac{7}{4} \text{ has no solution}$$

$$\text{Therefore } 3^x = \frac{1}{3}$$

So $x = -1$ is the only solution

© Pearson Education Ltd 2008

Solutionbank C2

Edexcel Modular Mathematics for AS and A-Level

Exponentials and logarithms

Exercise F, Question 1

Question:

Find, to 3 decimal places:

(a) $\log_7 120$

(b) $\log_3 45$

(c) $\log_2 19$

(d) $\log_{11} 3$

(e) $\log_6 4$

Solution:

$$(a) \log_7 120 = \frac{\log_{10} 120}{\log_{10} 7} = 2.460 \text{ (3 d.p.)}$$

$$(b) \log_3 45 = \frac{\log_{10} 45}{\log_{10} 3} = 3.465 \text{ (3 d.p.)}$$

$$(c) \log_2 19 = \frac{\log_{10} 19}{\log_{10} 2} = 4.248 \text{ (3 d.p.)}$$

$$(d) \log_{11} 3 = \frac{\log_{10} 3}{\log_{10} 11} = 0.458 \text{ (3 d.p.)}$$

$$(e) \log_6 4 = \frac{\log_{10} 4}{\log_{10} 6} = 0.774 \text{ (3 d.p.)}$$

© Pearson Education Ltd 2008

Solutionbank C2

Edexcel Modular Mathematics for AS and A-Level

Exponentials and logarithms

Exercise F, Question 2

Question:

Solve, giving your answer to 3 significant figures:

(a) $8^x = 14$

(b) $9^x = 99$

(c) $12^x = 6$

Solution:

(a) $\log 8^x = \log 14$

$x \log 8 = \log 14$

$$x = \frac{\log_{10} 14}{\log_{10} 8}$$

$x = 1.27$ (3 s.f.)

(b) $\log 9^x = \log 99$

$x \log 9 = \log 99$

$$x = \frac{\log_{10} 99}{\log_{10} 9}$$

$x = 2.09$ (3 s.f.)

(c) $\log 12^x = \log 6$

$x \log 12 = \log 6$

$$x = \frac{\log_{10} 6}{\log_{10} 12}$$

$x = 0.721$ (3 s.f.)

Solutionbank C2

Edexcel Modular Mathematics for AS and A-Level

Exponentials and logarithms

Exercise F, Question 3

Question:

Solve, giving your answer to 3 significant figures:

(a) $\log_2 x = 8 + 9 \log_x 2$

(b) $\log_4 x + 2 \log_x 4 + 3 = 0$

(c) $\log_2 x + \log_4 x = 2$

Solution:

(a) $\log_2 x = 8 + 9 \log_x 2$

$$\log_2 x = 8 + \frac{9}{\log_2 x}$$

Let $\log_2 x = y$

$$y = 8 + \frac{9}{y}$$

$$y^2 = 8y + 9$$

$$y^2 - 8y - 9 = 0$$

$$(y + 1)(y - 9) = 0$$

So $y = -1$ or $y = 9$

If $y = -1$, $\log_2 x = -1$

$$\Rightarrow x = 2^{-1} = \frac{1}{2}$$

If $y = 9$, $\log_2 x = 9$

$$\Rightarrow x = 2^9 = 512$$

So $x = \frac{1}{2}$ or $x = 512$

(b) $\log_4 x + 2 \log_x 4 + 3 = 0$

$$\log_4 x + \frac{2}{\log_4 x} + 3 = 0$$

Let $\log_4 x = y$

$$y + \frac{2}{y} + 3 = 0$$

$$y^2 + 2 + 3y = 0$$

$$y^2 + 3y + 2 = 0$$

$$(y + 1)(y + 2) = 0$$

So $y = -1$ or $y = -2$

If $y = -1$, $\log_4 x = -1$

$$\Rightarrow x = 4^{-1} = \frac{1}{4}$$

If $y = -2$, $\log_4 x = -2$

$$\Rightarrow x = 4^{-2} = \frac{1}{16}$$

$$\text{So } x = \frac{1}{4} \text{ or } x = \frac{1}{16}$$

$$\text{(c) } \log_2 x + \log_4 x = 2$$

$$\log_2 x + \frac{\log_2 x}{\log_2 4} = 2$$

But $\log_2 4 = 2$ (because $2^2 = 4$), so

$$\log_2 x + \frac{\log_2 x}{2} = 2$$

$$\frac{3}{2} \log_2 x = 2$$

$$\log_2 x = \frac{4}{3}$$

$$x = 2^{\frac{4}{3}}$$

$$x = 2.52 \text{ (3 s.f.)}$$

© Pearson Education Ltd 2008

Solutionbank C2

Edexcel Modular Mathematics for AS and A-Level

Exponentials and logarithms

Exercise G, Question 1

Question:

Find the possible values of x for which $2^{2x+1} = 3(2^x) - 1$. **[E]**

Solution:

$$2^{2x+1} = 3(2^x) - 1$$

$$2^{2x} \times 2^1 = 3(2^x) - 1$$

$$\text{Let } 2^x = y$$

$$2y^2 = 3y - 1$$

$$2y^2 - 3y + 1 = 0$$

$$(2y - 1)(y - 1) = 0$$

$$\text{So } y = \frac{1}{2} \text{ or } y = 1$$

$$\text{If } y = \frac{1}{2}, 2^x = \frac{1}{2}, x = -1$$

$$\text{If } y = 1, 2^x = 1, x = 0$$

$$\text{So } x = 0 \text{ or } x = -1$$

© Pearson Education Ltd 2008

Solutionbank C2

Edexcel Modular Mathematics for AS and A-Level

Exponentials and logarithms

Exercise G, Question 2

Question:

- (a) Express $\log_a (p^2q)$ in terms of $\log_a p$ and $\log_a q$.
- (b) Given that $\log_a (pq) = 5$ and $\log_a (p^2q) = 9$, find the values of $\log_a p$ and $\log_a q$. **[E]**

Solution:

(a) $\log_a (p^2q) = \log_a (p^2) + \log_a q = 2 \log_a p + \log_a q$

(b) $\log_a (pq) = \log_a p + \log_a q$

So

$$\log_a p + \log_a q = 5 \quad \text{①}$$

$$2 \log_a p + \log_a q = 9 \quad \text{②}$$

Subtracting equation ① from equation ②:

$$\log_a p = 4$$

$$\text{So } \log_a q = 1$$

Solutionbank C2

Edexcel Modular Mathematics for AS and A-Level

Exponentials and logarithms

Exercise G, Question 3

Question:

Given that $p = \log_q 16$, express in terms of p ,

(a) $\log_q 2$,

(b) $\log_q (8q)$. [E]

Solution:

(a) $p = \log_q 16$

$$p = \log_q (2^4)$$

$$p = 4 \log_q 2$$

$$\log_q 2 = \frac{p}{4}$$

(b) $\log_q (8q) = \log_q 8 + \log_q q$

$$= \log_q (2^3) + \log_q q$$

$$= 3 \log_q 2 + \log_q q$$

$$= \frac{3p}{4} + 1$$

Solutionbank C2

Edexcel Modular Mathematics for AS and A-Level

Exponentials and logarithms

Exercise G, Question 4

Question:

- (a) Given that $\log_3 x = 2$, determine the value of x .
- (b) Calculate the value of y for which $2 \log_3 y - \log_3 (y + 4) = 2$.
- (c) Calculate the values of z for which $\log_3 z = 4 \log_z 3$.

[E]

Solution:

(a) $\log_3 x = 2$
 $x = 3^2 = 9$

(b) $2 \log_3 y - \log_3 (y + 4) = 2$
 $\log_3 (y^2) - \log_3 (y + 4) = 2$
 $\log_3 \left(\frac{y^2}{y + 4} \right) = 2$

$$\frac{y^2}{y + 4} = 9$$

$$y^2 = 9y + 36$$

$$y^2 - 9y - 36 = 0$$

$$(y + 3)(y - 12) = 0$$

$$y = -3 \text{ or } y = 12$$

But $\log_3 (-3)$ is not defined,

So $y = 12$

(c) $\log_3 z = 4 \log_z 3$

$$\log_3 z = \frac{4}{\log_3 z}$$

$$(\log_3 z)^2 = 4$$

Either $\log_3 z = 2$ or $\log_3 z = -2$

$$z = 3^2 \text{ or } z = 3^{-2}$$

$$z = 9 \text{ or } z = \frac{1}{9}$$

Solutionbank C2

Edexcel Modular Mathematics for AS and A-Level

Exponentials and logarithms

Exercise G, Question 5

Question:

(a) Using the substitution $u = 2^x$, show that the equation $4^x - 2^{(x+1)} - 15 = 0$ can be written in the form $u^2 - 2u - 15 = 0$.

(b) Hence solve the equation $4^x - 2^{(x+1)} - 15 = 0$, giving your answer to 2 decimal places. **[E]**

Solution:

$$(a) 4^x - 2^{(x+1)} - 15 = 0$$

$$4^x = (2^2)^x = (2^x)^2$$

$$2^{x+1} = 2^x \times 2^1$$

$$\text{Let } u = 2^x$$

$$u^2 - 2u - 15 = 0$$

$$(b) (u + 3)(u - 5) = 0$$

$$\text{So } u = -3 \text{ or } u = 5$$

$$\text{If } u = -3, 2^x = -3. \text{ No solution.}$$

$$\text{If } u = 5, 2^x = 5$$

$$\log 2^x = \log 5$$

$$x \log 2 = \log 5$$

$$x = \frac{\log 5}{\log 2}$$

$$x = 2.32 \text{ (2 d.p.)}$$

Solutionbank C2

Edexcel Modular Mathematics for AS and A-Level

Exponentials and logarithms

Exercise G, Question 6

Question:

Solve, giving your answers as exact fractions, the simultaneous equations:

$$8^y = 4^{2x+3}$$
$$\log_2 y = \log_2 x + 4. \quad \text{[E]}$$

Solution:

$$8^y = 4^{2x+3}$$
$$(2^3)^y = (2^2)^{2x+3}$$
$$2^{3y} = 2^{2(2x+3)}$$
$$3y = 4x + 6 \quad \text{①}$$

$$\log_2 y - \log_2 x = 4$$

$$\log_2 \left(\frac{y}{x} \right) = 4$$

$$\frac{y}{x} = 2^4 = 16$$

$$y = 16x \quad \text{②}$$

Substitute ② into ①:

$$48x = 4x + 6$$

$$44x = 6$$

$$x = \frac{3}{22}$$

$$y = 16x = \frac{48}{22} = 2 \frac{2}{11}$$

$$\text{So } x = \frac{3}{22}, y = 2 \frac{2}{11}$$

Solutionbank C2

Edexcel Modular Mathematics for AS and A-Level

Exponentials and logarithms

Exercise G, Question 7

Question:

Find the values of x for which $\log_3 x - 2 \log_x 3 = 1$. [E]

Solution:

$$\log_3 x - 2 \log_x 3 = 1$$

$$\log_3 x - \frac{2}{\log_3 x} = 1$$

$$\text{Let } \log_3 x = y$$

$$y - \frac{2}{y} = 1$$

$$y^2 - 2 = y$$

$$y^2 - y - 2 = 0$$

$$(y + 1)(y - 2) = 0$$

$$\text{So } y = -1 \text{ or } y = 2$$

$$\text{If } y = -1, \log_3 x = -1$$

$$\Rightarrow x = 3^{-1} = \frac{1}{3}$$

$$\text{If } y = 2, \log_3 x = 2$$

$$\Rightarrow x = 3^2 = 9$$

$$\text{So } x = \frac{1}{3} \text{ or } x = 9$$

Solutionbank C2

Edexcel Modular Mathematics for AS and A-Level

Exponentials and logarithms

Exercise G, Question 8

Question:

Solve the equation

$$\log_3 (2 - 3x) = \log_9 (6x^2 - 19x + 2) . \quad \text{[E]}$$

Solution:

$$\log_3 (2 - 3x) = \log_9 (6x^2 - 19x + 2)$$

$$\log_9 \left(6x^2 - 19x + 2 \right) = \frac{\log_3 (6x^2 - 19x + 2)}{\log_3 9} = \frac{\log_3 (6x^2 - 19x + 2)}{2}$$

So

$$2 \log_3 (2 - 3x) = \log_3 (6x^2 - 19x + 2)$$

$$\log_3 (2 - 3x)^2 = \log_3 (6x^2 - 19x + 2)$$

$$(2 - 3x)^2 = 6x^2 - 19x + 2$$

$$4 - 12x + 9x^2 = 6x^2 - 19x + 2$$

$$3x^2 + 7x + 2 = 0$$

$$(3x + 1)(x + 2) = 0$$

$$x = -\frac{1}{3} \text{ or } x = -2$$

(Both solutions are valid, since they give logs of positive numbers in the original equation.)

Solutionbank C2

Edexcel Modular Mathematics for AS and A-Level

Exponentials and logarithms

Exercise G, Question 9

Question:

If $xy = 64$ and $\log_x y + \log_y x = \frac{5}{2}$, find x and y . [E]

Solution:

$$\log_x y + \log_y x = \frac{5}{2}$$

$$\log_x y + \frac{1}{\log_x y} = \frac{5}{2}$$

Let $\log_x y = u$

$$u + \frac{1}{u} = \frac{5}{2}$$

$$2u^2 + 2 = 5u$$

$$2u^2 - 5u + 2 = 0$$

$$(2u - 1)(u - 2) = 0$$

$$u = \frac{1}{2} \text{ or } u = 2$$

$$\text{If } u = \frac{1}{2}, \log_x y = \frac{1}{2}$$

$$\Rightarrow y = x^{\frac{1}{2}} = \sqrt{x}$$

Since $xy = 64$,

$$x\sqrt{x} = 64 \quad \left(x^{\frac{3}{2}} = 64 \right)$$

$$x = 16$$

$$y = \sqrt{x} = 4$$

If $u = 2, \log_x y = 2$

$$\Rightarrow y = x^2$$

Since $xy = 64$,

$$x^3 = 64$$

$$x = 4$$

$$y = x^2 = 16$$

So $x = 16, y = 4$ or $x = 4, y = 16$

Solutionbank C2

Edexcel Modular Mathematics for AS and A-Level

Exponentials and logarithms

Exercise G, Question 10

Question:

Prove that if $a^x = b^y = (ab)^{xy}$, then $x + y = 1$. [E]

Solution:

Given that $a^x = b^y = (ab)^{xy}$

Take logs to base a for $a^x = b^y$:

$$\log_a (a^x) = \log_a (b^y)$$

$$x \log_a a = y \log_a b$$

$$x = y \log_a b \quad \textcircled{1}$$

Take logs to base a for $a^x = (ab)^{xy}$

$$x = \log_a (ab)^{xy}$$

$$x = xy \log_a (ab)$$

$$x = xy (\log_a a + \log_a b)$$

$$x = xy (1 + \log_a b)$$

$$1 = y (1 + \log_a b) \quad \textcircled{2}$$

But, from $\textcircled{1}$, $\log_a b = \frac{x}{y}$

Substitute into $\textcircled{2}$:

$$1 = y \left(1 + \frac{x}{y} \right)$$

$$1 = y + x$$

$$x + y = 1$$

Solutionbank C2

Edexcel Modular Mathematics for AS and A-Level

Exponentials and logarithms

Exercise G, Question 11

Question:

(a) Show that $\log_4 3 = \log_2 \sqrt{3}$.

(b) Hence or otherwise solve the simultaneous equations:

$$2 \log_2 y = \log_4 3 + \log_2 x,$$

$$3^y = 9^x,$$

given that x and y are positive. **[E]**

Solution:

$$(a) \log_4 3 = \frac{\log_2 3}{\log_2 4} = \frac{\log_2 3}{2}$$

$$\log_4 3 = \frac{1}{2} \log_2 3 = \log_2 3^{\frac{1}{2}} = \log_2 \sqrt{3}$$

$$(b) 3^y = 9^x$$

$$3^y = (3^2)^x = 3^{2x}$$

$$\text{So } y = 2x$$

$$2 \log_2 y = \log_4 3 + \log_2 x$$

$$\log_2 (y^2) = \log_2 \sqrt{3} + \log_2 x = \log_2 (x \sqrt{3})$$

$$\text{So } y^2 = x \sqrt{3}$$

$$\text{Since } y = 2x, (2x)^2 = x \sqrt{3}$$

$$\Rightarrow 4x^2 = x \sqrt{3}$$

$$x \text{ is positive, so } x \neq 0, x = \frac{\sqrt{3}}{4}$$

$$\Rightarrow y = 2x = \frac{\sqrt{3}}{2}$$

$$\text{So } x = \frac{\sqrt{3}}{4}, y = \frac{\sqrt{3}}{2}$$

Solutionbank C2

Edexcel Modular Mathematics for AS and A-Level

Exponentials and logarithms

Exercise G, Question 12

Question:

- (a) Given that $3 + 2 \log_2 x = \log_2 y$, show that $y = 8x^2$.
- (b) Hence, or otherwise, find the roots α and β , where $\alpha < \beta$, of the equation $3 + 2 \log_2 x = \log_2 (14x - 3)$.
- (c) Show that $\log_2 \alpha = -2$.
- (d) Calculate $\log_2 \beta$, giving your answer to 3 significant figures. **[E]**

Solution:

$$(a) 3 + 2 \log_2 x = \log_2 y$$

$$\log_2 y - 2 \log_2 x = 3$$

$$\log_2 y - \log_2 x^2 = 3$$

$$\log_2 \left(\frac{y}{x^2} \right) = 3$$

$$\frac{y}{x^2} = 2^3 = 8$$

$$y = 8x^2$$

(b) Comparing equations,

$$y = 14x - 3$$

$$8x^2 = 14x - 3$$

$$8x^2 - 14x + 3 = 0$$

$$(4x - 1)(2x - 3) = 0$$

$$x = \frac{1}{4} \text{ or } x = \frac{3}{2}$$

$$\alpha = \frac{1}{4}, \beta = \frac{3}{2}$$

$$(c) \log_2 \alpha = \log_2 \left(\frac{1}{4} \right) = -2,$$

$$\text{since } 2^{-2} = \frac{1}{2^2} = \frac{1}{4}$$

$$(d) \log_2 \beta = \log_2 \left(\frac{3}{2} \right)$$

$$\log_2 1.5 = \frac{\log_{10} 1.5}{\log_{10} 2} = 0.585 \text{ (3 s.f.)}$$

Solutionbank C2

Edexcel Modular Mathematics for AS and A-Level

Coordinate geometry in the (x,y) plane

Exercise A, Question 1

Question:

Find the mid-point of the line joining these pairs of points:

(a) $(4, 2)$, $(6, 8)$

(b) $(0, 6)$, $(12, 2)$

(c) $(2, 2)$, $(-4, 6)$

(d) $(-6, 4)$, $(6, -4)$

(e) $(-5, 3)$, $(7, 5)$

(f) $(7, -4)$, $(-3, 6)$

(g) $(-5, -5)$, $(-11, 8)$

(h) $(6a, 4b)$, $(2a, -4b)$

(i) $(2p, -q)$, $(4p, 5q)$

(j) $(-2s, -7t)$, $(5s, t)$

(k) $(-4u, 0)$, $(3u, -2v)$

(l) $(a + b, 2a - b)$, $(3a - b, -b)$

(m) $(4\sqrt{2}, 1)$, $(2\sqrt{2}, 7)$

(n) $(-\sqrt{3}, 3\sqrt{5})$, $(5\sqrt{3}, 2\sqrt{5})$

(o) $(\sqrt{2} - \sqrt{3}, 3\sqrt{2} + 4\sqrt{3})$, $(3\sqrt{2} + \sqrt{3}, -\sqrt{2} + 2\sqrt{3})$

Solution:

(a) $(x_1, y_1) = (4, 2)$, $(x_2, y_2) = (6, 8)$

$$\text{So } \left(\frac{x_1 + x_2}{2}, \frac{y_1 + y_2}{2} \right) = \left(\frac{4 + 6}{2}, \frac{2 + 8}{2} \right) = \left(\frac{10}{2}, \frac{10}{2} \right) = (5, 5)$$

(b) $(x_1, y_1) = (0, 6)$, $(x_2, y_2) = (12, 2)$

$$\text{So } \left(\frac{x_1 + x_2}{2}, \frac{y_1 + y_2}{2} \right) = \left(\frac{0 + 12}{2}, \frac{6 + 2}{2} \right) = \left(\frac{12}{2}, \frac{8}{2} \right) = (6, 4)$$

(c) $(x_1, y_1) = (2, 2)$, $(x_2, y_2) = (-4, 6)$

$$\text{So } \left(\frac{x_1 + x_2}{2}, \frac{y_1 + y_2}{2} \right) = \left(\frac{2 + (-4)}{2}, \frac{2 + 6}{2} \right) = \left(\frac{-2}{2}, \frac{8}{2} \right) = (-1, 4)$$

$$(d) (x_1, y_1) = (-6, 4), (x_2, y_2) = (6, -4)$$

$$\text{So } \left(\frac{x_1 + x_2}{2}, \frac{y_1 + y_2}{2} \right) = \left(\frac{-6 + 6}{2}, \frac{4 + (-4)}{2} \right) = \left(\frac{0}{2}, \frac{0}{2} \right) = \left(0, 0 \right)$$

$$(e) (x_1, y_1) = (-5, 3), (x_2, y_2) = (7, 5)$$

$$\text{So } \left(\frac{x_1 + x_2}{2}, \frac{y_1 + y_2}{2} \right) = \left(\frac{-5 + 7}{2}, \frac{3 + 5}{2} \right) = \left(\frac{2}{2}, \frac{8}{2} \right) = \left(1, 4 \right)$$

$$(f) (x_1, y_1) = (7, -4), (x_2, y_2) = (-3, 6)$$

$$\text{So } \left(\frac{x_1 + x_2}{2}, \frac{y_1 + y_2}{2} \right) = \left(\frac{7 + (-3)}{2}, \frac{-4 + 6}{2} \right) = \left(\frac{4}{2}, \frac{2}{2} \right) = \left(2, 1 \right)$$

$$(g) (x_1, y_1) = (-5, -5), (x_2, y_2) = (-11, 8)$$

$$\text{So } \left(\frac{x_1 + x_2}{2}, \frac{y_1 + y_2}{2} \right) = \left(\frac{-5 + (-11)}{2}, \frac{-5 + 8}{2} \right) = \left(\frac{-16}{2}, \frac{3}{2} \right) = \left(-8, \frac{3}{2} \right)$$

$$(h) (x_1, y_1) = (6a, 4b), (x_2, y_2) = (2a, -4b)$$

$$\text{So } \left(\frac{x_1 + x_2}{2}, \frac{y_1 + y_2}{2} \right) = \left(\frac{6a + 2a}{2}, \frac{4b + (-4b)}{2} \right) = \left(\frac{8a}{2}, \frac{0}{2} \right) = \left(4a, 0 \right)$$

$$(i) (x_1, y_1) = (2p, -q), (x_2, y_2) = (4p, 5q)$$

$$\text{So } \left(\frac{x_1 + x_2}{2}, \frac{y_1 + y_2}{2} \right) = \left(\frac{2p + 4p}{2}, \frac{-q + 5q}{2} \right) = \left(\frac{6p}{2}, \frac{4q}{2} \right) = \left(3p, 2q \right)$$

$$(j) (x_1, y_1) = (-2s, -7t), (x_2, y_2) = (5s, t)$$

$$\text{So } \left(\frac{x_1 + x_2}{2}, \frac{y_1 + y_2}{2} \right) = \left(\frac{-2s + 5s}{2}, \frac{-7t + t}{2} \right) = \left(\frac{3s}{2}, \frac{-6t}{2} \right) = \left(\frac{3s}{2}, -3t \right)$$

$$(k) (x_1, y_1) = (-4u, 0), (x_2, y_2) = (3u, -2v)$$

$$\text{So } \left(\frac{x_1 + x_2}{2}, \frac{y_1 + y_2}{2} \right) = \left(\frac{-4u + 3u}{2}, \frac{0 + (-2v)}{2} \right) = \left(\frac{-u}{2}, -v \right)$$

$$(l) (x_1, y_1) = (a + b, 2a - b), (x_2, y_2) = (3a - b, -b)$$

$$\text{So } \left(\frac{x_1 + x_2}{2}, \frac{y_1 + y_2}{2} \right) = \left(\frac{a + b + 3a - b}{2}, \frac{2a - b + (-b)}{2} \right) = \left(\frac{4a}{2}, \frac{2a - 2b}{2} \right) = \left(2a, a - b \right)$$

$$(m) (x_1, y_1) = (4\sqrt{2}, 1), (x_2, y_2) = (2\sqrt{2}, 7)$$

$$\text{So } \left(\frac{x_1 + x_2}{2}, \frac{y_1 + y_2}{2} \right) = \left(\frac{4\sqrt{2} + 2\sqrt{2}}{2}, \frac{1 + 7}{2} \right) = \left(\frac{6\sqrt{2}}{2}, \frac{8}{2} \right) = \left(3\sqrt{2}, 4 \right)$$

$$(n) (x_1, y_1) = (-\sqrt{3}, 3\sqrt{5}), (x_2, y_2) = (5\sqrt{3}, 2\sqrt{5})$$

$$\text{So } \left(\frac{x_1 + x_2}{2}, \frac{y_1 + y_2}{2} \right) = \left(\frac{-\sqrt{3} + 5\sqrt{3}}{2}, \frac{3\sqrt{5} + 2\sqrt{5}}{2} \right) = \left(\frac{4\sqrt{3}}{2}, \frac{5\sqrt{5}}{2} \right) = \left(2\sqrt{3}, \frac{5\sqrt{5}}{2} \right)$$

$$(o) (x_1, y_1) = (\sqrt{2} - \sqrt{3}, 3\sqrt{2} + 4\sqrt{3}), (x_2, y_2) = (3\sqrt{2} + \sqrt{3}, -\sqrt{2} + 2\sqrt{3})$$

$$\text{So } \left(\frac{x_1 + x_2}{2}, \frac{y_1 + y_2}{2} \right) = \left(\frac{\sqrt{2} - \sqrt{3} + 3\sqrt{2} + \sqrt{3}}{2}, \frac{3\sqrt{2} + 4\sqrt{3} + (-\sqrt{2} + 2\sqrt{3})}{2} \right)$$

$$= \left(\frac{\sqrt{2} - \sqrt{3} + 3\sqrt{2} + \sqrt{3}}{2}, \frac{3\sqrt{2} + 4\sqrt{3} - \sqrt{2} + 2\sqrt{3}}{2} \right)$$

$$= \left(\frac{4\sqrt{2}}{2}, \frac{2\sqrt{2} + 6\sqrt{3}}{2} \right)$$

$$= (2\sqrt{2}, \sqrt{2} + 3\sqrt{3})$$

© Pearson Education Ltd 2008

Solutionbank C2

Edexcel Modular Mathematics for AS and A-Level

Coordinate geometry in the (x,y) plane

Exercise A, Question 2

Question:

The line PQ is a diameter of a circle, where P and Q are $(-4, 6)$ and $(7, 8)$ respectively. Find the coordinates of the centre of the circle.

Solution:

$$(x_1, y_1) = (-4, 6), (x_2, y_2) = (7, 8)$$
$$\text{So } \left(\frac{x_1 + x_2}{2}, \frac{y_1 + y_2}{2} \right) = \left(\frac{-4 + 7}{2}, \frac{6 + 8}{2} \right) = \left(\frac{3}{2}, \frac{14}{2} \right) = \left(\frac{3}{2}, 7 \right)$$

$$\text{The centre is } \left(\frac{3}{2}, 7 \right).$$

© Pearson Education Ltd 2008

Solutionbank C2

Edexcel Modular Mathematics for AS and A-Level

Coordinate geometry in the (x,y) plane

Exercise A, Question 3

Question:

The line RS is a diameter of a circle, where R and S are $\left(\frac{4a}{5}, -\frac{3b}{4}\right)$ and $\left(\frac{2a}{5}, \frac{5b}{4}\right)$ respectively. Find the coordinates of the centre of the circle.

Solution:

$$\begin{aligned} \left(x_1, y_1\right) &= \left(\frac{4a}{5}, -\frac{3b}{4}\right), \quad \left(x_2, y_2\right) = \left(\frac{2a}{5}, \frac{5b}{4}\right) \\ \text{So } \left(\frac{x_1+x_2}{2}, \frac{y_1+y_2}{2}\right) &= \left(\frac{\frac{4a}{5} + \frac{2a}{5}}{2}, \frac{-\frac{3b}{4} + \frac{5b}{4}}{2}\right) = \left(\frac{\frac{6a}{5}}{2}, \frac{\frac{2b}{4}}{2}\right) = \left(\frac{3a}{5}, \frac{b}{4}\right) \end{aligned}$$

The centre is $\left(\frac{3a}{5}, \frac{b}{4}\right)$.

Solutionbank C2

Edexcel Modular Mathematics for AS and A-Level

Coordinate geometry in the (x,y) plane

Exercise A, Question 4

Question:

The line AB is a diameter of a circle, where A and B are $(-3, -4)$ and $(6, 10)$ respectively. Show that the centre of the circle lies on the line $y = 2x$.

Solution:

$$(x_1, y_1) = (-3, -4), (x_2, y_2) = (6, 10)$$
$$\text{So } \left(\frac{x_1 + x_2}{2}, \frac{y_1 + y_2}{2} \right) = \left(\frac{-3 + 6}{2}, \frac{-4 + 10}{2} \right) = \left(\frac{3}{2}, \frac{6}{2} \right) = \left(\frac{3}{2}, 3 \right)$$

Substitute $x = \frac{3}{2}$ into $y = 2x$:

$$y = 2 \left(\frac{3}{2} \right) = 3 \quad \checkmark$$

So the centre is on the line $y = 2x$.

Solutionbank C2

Edexcel Modular Mathematics for AS and A-Level

Coordinate geometry in the (x,y) plane

Exercise A, Question 5

Question:

The line JK is a diameter of a circle, where J and K are $\left(\frac{3}{4}, \frac{4}{3}\right)$ and $\left(-\frac{1}{2}, 2\right)$ respectively. Show that the centre of the circle lies on the line $y = 8x + \frac{2}{3}$.

Solution:

$$\begin{aligned} \left(x_1, y_1\right) &= \left(\frac{3}{4}, \frac{4}{3}\right), \quad \left(x_2, y_2\right) = \left(-\frac{1}{2}, 2\right) \\ \text{So } \left(\frac{x_1+x_2}{2}, \frac{y_1+y_2}{2}\right) &= \left(\frac{\frac{3}{4} + \left(-\frac{1}{2}\right)}{2}, \frac{\frac{4}{3} + 2}{2}\right) = \left(\frac{\frac{1}{4}}{2}, \frac{\frac{10}{3}}{2}\right) = \left(\frac{1}{8}, \frac{5}{3}\right) \end{aligned}$$

Substitute $x = \frac{1}{8}$ into $y = 8x + \frac{2}{3}$:

$$y = 8 \left(\frac{1}{8}\right) + \frac{2}{3} = 1 + \frac{2}{3} = \frac{5}{3} \checkmark$$

So the centre is on the line $y = 8x + \frac{2}{3}$.

Solutionbank C2

Edexcel Modular Mathematics for AS and A-Level

Coordinate geometry in the (x,y) plane

Exercise A, Question 6

Question:

The line AB is a diameter of a circle, where A and B are $(0, -2)$ and $(6, -5)$ respectively. Show that the centre of the circle lies on the line $x - 2y - 10 = 0$.

Solution:

$$(x_1, y_1) = (0, -2), (x_2, y_2) = (6, -5)$$
$$\text{So } \left(\frac{x_1 + x_2}{2}, \frac{y_1 + y_2}{2} \right) = \left(\frac{0 + 6}{2}, \frac{-2 + (-5)}{2} \right) = \left(\frac{6}{2}, \frac{-7}{2} \right) = \left(3, \frac{-7}{2} \right)$$

Substitute $x = 3$ and $y = \frac{-7}{2}$ into $x - 2y - 10 = 0$:

$$\left(3 \right) - 2 \left(\frac{-7}{2} \right) - 10 = 3 + 7 - 10 = 0 \quad \checkmark$$

So the centre is on the line $x - 2y - 10 = 0$.

Solutionbank C2

Edexcel Modular Mathematics for AS and A-Level

Coordinate geometry in the (x,y) plane
Exercise A, Question 7

Question:

The line FG is a diameter of the circle centre $(6, 1)$. Given F is $(2, -3)$, find the coordinates of G .

Solution:

$$(x_1, y_1) = (a, b), (x_2, y_2) = (2, -3)$$

The centre is $(6, 1)$ so

$$\left(\frac{a+2}{2}, \frac{b+(-3)}{2} \right) = (6, 1)$$

$$\frac{a+2}{2} = 6$$

$$a+2 = 12$$

$$a = 10$$

$$\frac{b+(-3)}{2} = 1$$

$$\frac{b-3}{2} = 1$$

$$b-3 = 2$$

$$b = 5$$

The coordinates of G are $(10, 5)$.

Solutionbank C2

Edexcel Modular Mathematics for AS and A-Level

Coordinate geometry in the (x,y) plane

Exercise A, Question 8

Question:

The line CD is a diameter of the circle centre $(-2a, 5a)$. Given D has coordinates $(3a, -7a)$, find the coordinates of C .

Solution:

$$(x_1, y_1) = (p, q), (x_2, y_2) = (3a, -7a)$$

The centre is $(-2a, 5a)$ so

$$\left(\frac{p+3a}{2}, \frac{q+(-7a)}{2} \right) = \left(-2a, 5a \right)$$

$$\frac{p+3a}{2} = -2a$$

$$p+3a = -4a$$

$$p = -7a$$

$$\frac{q+(-7a)}{2} = 5a$$

$$\frac{q-7a}{2} = 5a$$

$$q-7a = 10a$$

$$q = 17a$$

The coordinates of C are $(-7a, 17a)$.

Solutionbank C2

Edexcel Modular Mathematics for AS and A-Level

Coordinate geometry in the (x,y) plane

Exercise A, Question 9

Question:

The points $M(3, p)$ and $N(q, 4)$ lie on the circle centre $(5, 6)$. The line MN is a diameter of the circle. Find the value of p and q .

Solution:

$(x_1, y_1) = (3, p)$, $(x_2, y_2) = (q, 4)$ so

$$\left(\frac{3+q}{2}, \frac{p+4}{2} \right) = (5, 6)$$

$$\frac{3+q}{2} = 5$$

$$3+q = 10$$

$$q = 7$$

$$\frac{p+4}{2} = 6$$

$$p+4 = 12$$

$$p = 8$$

So $p = 8, q = 7$

Solutionbank C2

Edexcel Modular Mathematics for AS and A-Level

Coordinate geometry in the (x,y) plane

Exercise A, Question 10

Question:

The points $V(-4, 2a)$ and $W(3b, -4)$ lie on the circle centre $(b, 2a)$. The line VW is a diameter of the circle. Find the value of a and b .

Solution:

$(x_1, y_1) = (-4, 2a)$, $(x_2, y_2) = (3b, -4)$ so

$$\left(\frac{-4 + 3b}{2}, \frac{2a - 4}{2} \right) = \left(b, 2a \right)$$

$$\frac{-4 + 3b}{2} = b$$

$$-4 + 3b = 2b$$

$$-4 = -b$$

$$b = 4$$

$$\frac{2a - 4}{2} = 2a$$

$$2a - 4 = 4a$$

$$-4 = 2a$$

$$a = -2$$

So $a = -2$, $b = 4$

Solutionbank C2

Edexcel Modular Mathematics for AS and A-Level

Coordinate geometry in the (x,y) plane

Exercise B, Question 1

Question:

The line FG is a diameter of the circle centre C , where F and G are $(-2, 5)$ and $(2, 9)$ respectively. The line l passes through C and is perpendicular to FG . Find the equation of l .

Solution:

(1)

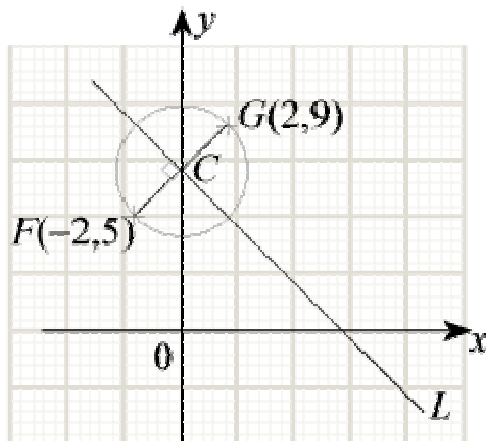

(2) The gradient of FG is

$$\frac{y_2 - y_1}{x_2 - x_1} = \frac{9 - 5}{2 - (-2)} = \frac{4}{4} = 1$$

(3) The gradient of a line perpendicular to FG is $\frac{-1}{(1)} = -1$.

(4) C is the mid-point of FG , so the coordinates of C are

$$\left(\frac{x_1 + x_2}{2}, \frac{y_1 + y_2}{2} \right) = \left(\frac{-2 + 2}{2}, \frac{5 + 9}{2} \right) = \left(\frac{0}{2}, \frac{14}{2} \right) = (0, 7)$$

(5) The equation of l is

$$y - y_1 = m(x - x_1)$$

$$y - 7 = -1(x - 0)$$

$$y - 7 = -x$$

$$y = -x + 7$$

Solutionbank C2

Edexcel Modular Mathematics for AS and A-Level

Coordinate geometry in the (x,y) plane

Exercise B, Question 2

Question:

The line JK is a diameter of the circle centre P , where J and K are $(0, -3)$ and $(4, -5)$ respectively. The line l passes through P and is perpendicular to JK . Find the equation of l . Write your answer in the form $ax + by + c = 0$, where a , b and c are integers.

Solution:

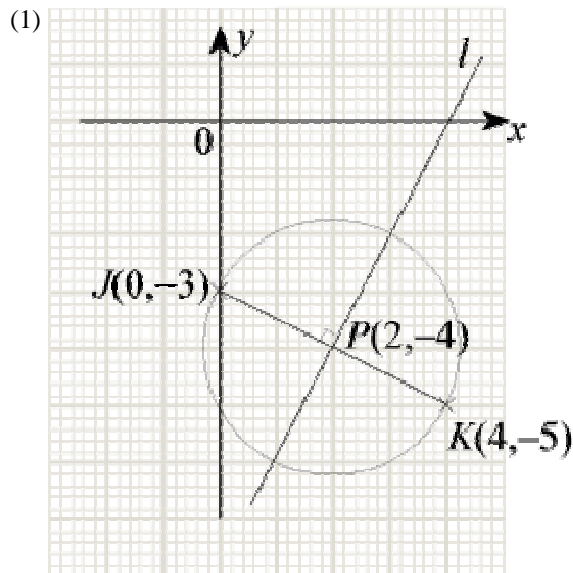

(2) The gradient of JK is

$$\frac{y_2 - y_1}{x_2 - x_1} = \frac{-5 - (-3)}{4 - 0} = \frac{-5 + 3}{4} = \frac{-2}{4} = \frac{-1}{2}$$

(3) The gradient of a line perpendicular to JK is $\frac{-1}{\left(\frac{-1}{2}\right)} = 2$

(4) P is the mid-point of JK , so the coordinates of P are

$$\left(\frac{x_1 + x_2}{2}, \frac{y_1 + y_2}{2} \right) = \left(\frac{0 + 4}{2}, \frac{-3 + (-5)}{2} \right) = \left(\frac{4}{2}, \frac{-8}{2} \right) = (2, -4)$$

(5) The equation of l is

$$\begin{aligned} y - y_1 &= m(x - x_1) \\ y - (-4) &= 2(x - 2) \\ y + 4 &= 2x - 4 \\ 0 &= 2x - y - 4 - 4 \\ 2x - y - 8 &= 0 \end{aligned}$$

Solutionbank C2

Edexcel Modular Mathematics for AS and A-Level

Coordinate geometry in the (x,y) plane

Exercise B, Question 3

Question:

The line AB is a diameter of the circle centre $(4, -2)$. The line l passes through B and is perpendicular to AB . Given that A is $(-2, 6)$,

(a) find the coordinates of B .

(b) Hence, find the equation of l .

Solution:

(1)

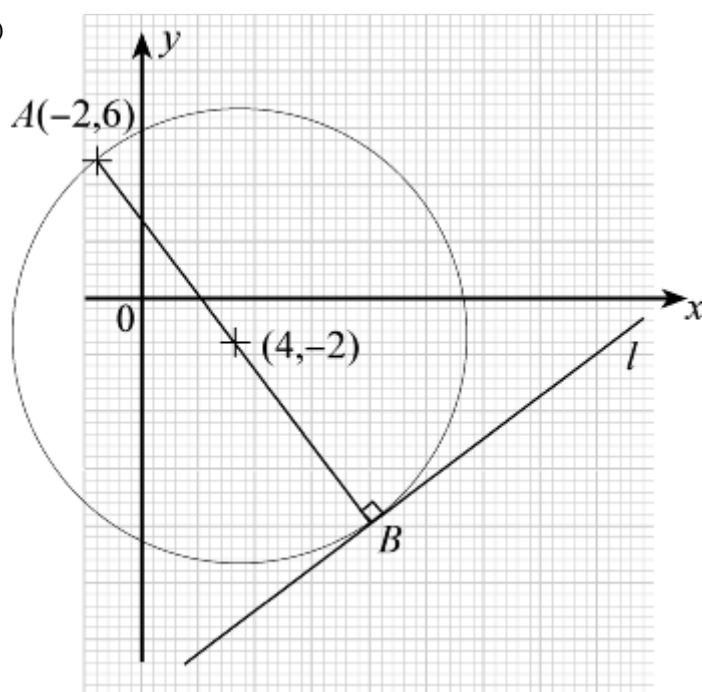

(2) Let the coordinates of B be (a, b) .

$(4, -2)$ is the mid-point of AB so

$$\left(\frac{x_1 + x_2}{2}, \frac{y_1 + y_2}{2} \right) = (4, -2)$$

$$\text{i.e. } \left(\frac{-2 + a}{2}, \frac{6 + b}{2} \right) = (4, -2)$$

So

$$\frac{-2 + a}{2} = 4$$

$$-2 + a = 8$$

$$a = 10$$

and

$$\frac{6 + b}{2} = -2$$

$$6 + b = -4$$

$$b = -10$$

(a) The coordinates of B are $(10, -10)$.

(3) Using $(-2, 6)$ and $(4, -2)$, the gradient of AB is

$$\frac{y_2 - y_1}{x_2 - x_1} = \frac{-2 - 6}{4 - (-2)} = \frac{-8}{6} = \frac{-4}{3}$$

(4) The gradient of a line perpendicular to AB is $\frac{-1}{\left(\frac{-4}{3}\right)} = \frac{3}{4}$

(5) The equation of l is

$$y - y_1 = m(x - x_1)$$

$$y - \left(-10\right) = \frac{3}{4} \left(x - 10\right)$$

$$y + 10 = \frac{3x}{4} - \frac{30}{4}$$

$$y = \frac{3x}{4} - \frac{30}{4} - 10$$

$$y = \frac{3x}{4} - \frac{70}{4}$$

$$y = \frac{3x}{4} - \frac{35}{2}$$

(b) The equation of l is $y = \frac{3}{4}x - \frac{35}{2}$.

Solutionbank C2

Edexcel Modular Mathematics for AS and A-Level

Coordinate geometry in the (x,y) plane

Exercise B, Question 4

Question:

The line PQ is a diameter of the circle centre $(-4, -2)$. The line l passes through P and is perpendicular to PQ . Given that Q is $(10, 4)$, find the equation of l .

Solution:

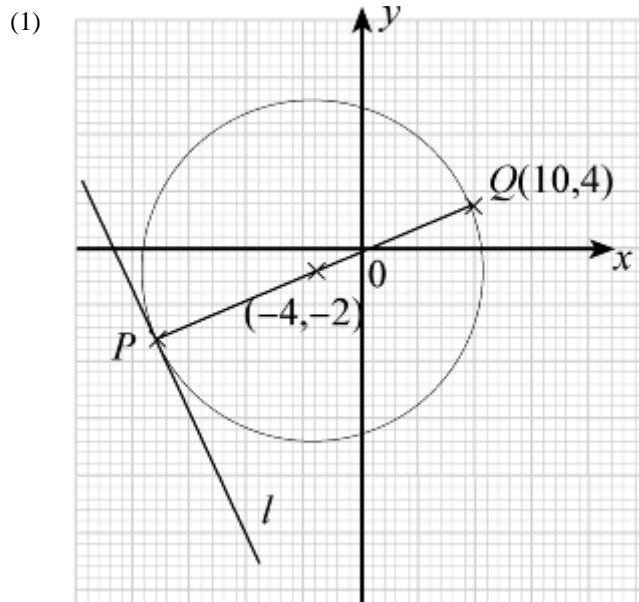

(2) Let the coordinates of P be (a, b) .
 $(-4, -2)$ is the mid-point of PQ so

$$\left(\frac{10+a}{2}, \frac{4+b}{2} \right) = (-4, -2)$$

$$\frac{10+a}{2} = -4$$

$$10+a = -8$$

$$a = -18$$

$$\frac{4+b}{2} = -2$$

$$4+b = -4$$

$$b = -8$$

The coordinates of P are $(-18, -8)$.

(3) The gradient of PQ is

$$\frac{y_2 - y_1}{x_2 - x_1} = \frac{4 - (-2)}{10 - (-18)} = \frac{6}{28} = \frac{3}{14}$$

(4) The gradient of a line perpendicular to PQ is $\frac{-1}{\left(\frac{3}{14}\right)} = \frac{-7}{3}$.

(5) The equation of l is

$$y - y_1 = m (x - x_1)$$

$$y - \left(-8 \right) = \frac{-7}{3} \left[x - \left(-18 \right) \right]$$

$$y + 8 = \frac{-7}{3} \left(x + 18 \right)$$

$$y + 8 = \frac{-7}{3} x - 42$$

$$y = \frac{-7}{3} x - 50$$

© Pearson Education Ltd 2008

Solutionbank C2

Edexcel Modular Mathematics for AS and A-Level

Coordinate geometry in the (x,y) plane

Exercise B, Question 5

Question:

The line RS is a chord of the circle centre $(5, -2)$, where R and S are $(2, 3)$ and $(10, 1)$ respectively. The line l is perpendicular to RS and bisects it. Show that l passes through the centre of the circle.

Solution:

(1) The gradient of RS is

$$\frac{y_2 - y_1}{x_2 - x_1} = \frac{1 - 3}{10 - 2} = \frac{-2}{8} = \frac{-1}{4}$$

(2) The gradient of a line perpendicular to RS is $\frac{-1}{\left(\frac{-1}{4}\right)} = 4$.

(3) The mid-point of RS is

$$\left(\frac{x_1 + x_2}{2}, \frac{y_1 + y_2}{2} \right) = \left(\frac{2 + 10}{2}, \frac{3 + 1}{2} \right) = \left(\frac{12}{2}, \frac{4}{2} \right) = (6, 2)$$

(4) The equation of l is

$$y - y_1 = m(x - x_1)$$

$$y - 2 = 4(x - 6)$$

$$y - 2 = 4x - 24$$

$$y = 4x - 22$$

(5) Substitute $x = 5$ into $y = 4x - 22$:

$$y = 4(5) - 22 = 20 - 22 = -2 \checkmark$$

So l passes through the centre of the circle.

Solutionbank C2

Edexcel Modular Mathematics for AS and A-Level

Coordinate geometry in the (x,y) plane

Exercise B, Question 6

Question:

The line MN is a chord of the circle centre $\left(1, -\frac{1}{2}\right)$, where M and N are $(-5, -5)$ and $(7, 4)$

respectively. The line l is perpendicular to MN and bisects it. Find the equation of l . Write your answer in the form $ax + by + c = 0$, where a , b and c are integers.

Solution:

(1) The gradient of MN is

$$\frac{y_2 - y_1}{x_2 - x_1} = \frac{4 - (-5)}{7 - (-5)} = \frac{4 + 5}{7 + 5} = \frac{9}{12} = \frac{3}{4}$$

(2) The gradient of a line perpendicular to MN is $\frac{-1}{\left(\frac{3}{4}\right)} = \frac{-4}{3}$.

(3) The coordinates of the mid-point of MN are

$$\left(\frac{x_1 + x_2}{2}, \frac{y_1 + y_2}{2}\right) = \left(\frac{-5 + 7}{2}, \frac{-5 + 4}{2}\right) = \left(\frac{2}{2}, \frac{-1}{2}\right) = \left(1, \frac{-1}{2}\right)$$

(4) The equation of l is

$$y - y_1 = m(x - x_1)$$

$$y - \left(\frac{-1}{2}\right) = \frac{-4}{3} \left(x - 1\right)$$

$$y + \frac{1}{2} = \frac{-4}{3} \left(x - 1\right)$$

$$y + \frac{1}{2} = \frac{-4}{3}x + \frac{4}{3}$$

$$(\times 6)$$

$$6y + 3 = -8x + 8$$

$$8x + 6y + 3 = 8$$

$$8x + 6y - 5 = 0$$

Solutionbank C2

Edexcel Modular Mathematics for AS and A-Level

Coordinate geometry in the (x,y) plane

Exercise B, Question 7

Question:

The lines AB and CD are chords of a circle. The line $y = 2x + 8$ is the perpendicular bisector of AB . The line $y = -2x - 4$ is the perpendicular bisector of CD . Find the coordinates of the centre of the circle.

Solution:

$$y = 2x + 8$$

$$y = -2x - 4$$

$$\hline 2y = 4$$

$$y = 2$$

Substitute $y = 2$ into $y = 2x + 8$:

$$2 = 2x + 8$$

$$-6 = 2x$$

$$x = -3$$

Check.

Substitute $x = -3$ and $y = 2$ into $y = -2x - 4$:

$$(2) = -2(-3) - 4$$

$$2 = 6 - 4$$

$$2 = 2 \quad \checkmark$$

The coordinates of the centre of the circle are $(-3, 2)$.

Solutionbank C2

Edexcel Modular Mathematics for AS and A-Level

Coordinate geometry in the (x,y) plane

Exercise B, Question 8

Question:

The lines EF and GH are chords of a circle. The line $y = 3x - 24$ is the perpendicular bisector of EF . Given G and F are $(-2, 4)$ and $(4, 10)$ respectively, find the coordinates of the centre of the circle.

Solution:

(1) The gradient of GF is

$$\frac{y_2 - y_1}{x_2 - x_1} = \frac{10 - 4}{4 - (-2)} = \frac{6}{6} = 1$$

(2) The gradient of a line perpendicular to GF is $-\frac{1}{(1)} = -1$.

(3) The mid-point of GF is

$$\left(\frac{x_1 + x_2}{2}, \frac{y_1 + y_2}{2} \right) = \left(\frac{-2 + 4}{2}, \frac{4 + 10}{2} \right) = \left(\frac{2}{2}, \frac{14}{2} \right) = (1, 7)$$

(4) The equation of the perpendicular bisector is

$$y - y_1 = m(x - x_1)$$

$$y - 7 = -1(x - 1)$$

$$y - 7 = -x + 1$$

$$y = -x + 8$$

(5) Solving $y = -x + 8$ and $y = 3x - 24$ simultaneously:

$$-x + 8 = 3x - 24$$

$$-4x = -32$$

$$x = \frac{-32}{-4}$$

$$x = 8$$

Substitute $x = 8$ into $y = -x + 8$:

$$y = -(8) + 8$$

$$y = -8 + 8$$

$$y = 0$$

So the centre of the circle is $(8, 0)$.

Solutionbank C2

Edexcel Modular Mathematics for AS and A-Level

Coordinate geometry in the (x,y) plane

Exercise B, Question 9

Question:

The points $P(3, 16)$, $Q(11, 12)$ and $R(-7, 6)$ lie on the circumference of a circle.

(a) Find the equation of the perpendicular bisector of

(i) PQ

(ii) PR .

(b) Hence, find the coordinates of the centre of the circle.

Solution:

(a) (i) The gradient PQ is

$$\frac{y_2 - y_1}{x_2 - x_1} = \frac{12 - 16}{11 - 3} = \frac{-4}{8} = \frac{-1}{2}$$

The gradient of a line perpendicular to PQ is $\frac{-1}{\left(\frac{-1}{2}\right)} = 2$.

The mid-point of PQ is

$$\left(\frac{x_1 + x_2}{2}, \frac{y_1 + y_2}{2} \right) = \left(\frac{3 + 11}{2}, \frac{16 + 12}{2} \right) = (7, 14)$$

The equation of the perpendicular bisector of PQ is

$$y - y_1 = m(x - x_1)$$

$$y - 14 = 2(x - 7)$$

$$y - 14 = 2x - 14$$

$$y = 2x$$

(ii) The gradient of PR is

$$\frac{y_2 - y_1}{x_2 - x_1} = \frac{6 - 16}{-7 - 3} = \frac{-10}{-10} = 1$$

The gradient of a line perpendicular to PR is $-\frac{1}{(1)} = -1$.

The mid-point of PR is

$$\left(\frac{x_1 + x_2}{2}, \frac{y_1 + y_2}{2} \right) = \left(\frac{3 + (-7)}{2}, \frac{16 + 6}{2} \right) = \left(\frac{3 - 7}{2}, \frac{22}{2} \right) = (-2, 11)$$

The equation of the perpendicular bisector of PR is

$$y - y_1 = m(x - x_1)$$

$$y - 11 = -1[x - (-2)]$$

$$y - 11 = -1(x + 2)$$

$$y - 11 = -x - 2$$

$$y = -x + 9$$

(b) Solving $y = 2x$ and $y = -x + 9$ simultaneously:

$$2x = -x + 9$$

$$3x = 9$$

$$x = 3$$

Substitute $x = 3$ in $y = 2x$:

$$y = 2(3)$$

$$y = 6$$

Check.

Substitute $x = 3$ and $y = 6$ into $y = -x + 9$:

$$(6) = -(3) + 9$$

$$6 = -3 + 9$$

$$6 = 6 \quad \checkmark$$

The coordinates of the centre are $(3, 6)$.

© Pearson Education Ltd 2008

Solutionbank C2

Edexcel Modular Mathematics for AS and A-Level

Coordinate geometry in the (x,y) plane

Exercise B, Question 10

Question:

The points $A(-3, 19)$, $B(9, 11)$ and $C(-15, 1)$ lie on the circumference of a circle. Find the coordinates of the centre of the circle.

Solution:

(1) The gradient of AB is

$$\frac{y_2 - y_1}{x_2 - x_1} = \frac{11 - 19}{9 - (-3)} = \frac{-8}{12} = \frac{-2}{3}$$

The gradient of a line perpendicular to AB is $\frac{-1}{\left(\frac{-2}{3}\right)} = \frac{3}{2}$.

The mid-point of AB is

$$\left(\frac{x_1 + x_2}{2}, \frac{y_1 + y_2}{2} \right) = \left(\frac{-3 + 9}{2}, \frac{19 + 11}{2} \right) = \left(\frac{6}{2}, \frac{30}{2} \right) = (3, 15)$$

The equation of the perpendicular bisector of AB is

$$y - y_1 = m(x - x_1)$$

$$y - 15 = \frac{3}{2}(x - 3)$$

$$y - 15 = \frac{3}{2}x - \frac{9}{2}$$

$$y = \frac{3}{2}x + \frac{21}{2}$$

(2) The gradient of BC is

$$\frac{y_2 - y_1}{x_2 - x_1} = \frac{1 - 11}{-15 - 9} = \frac{-10}{-24} = \frac{5}{12}$$

The gradient of a line perpendicular to BC is $\frac{-1}{\left(\frac{5}{12}\right)} = \frac{-12}{5}$

The mid-point of BC is

$$\left(\frac{x_1 + x_2}{2}, \frac{y_1 + y_2}{2} \right) = \left(\frac{9 + (-15)}{2}, \frac{11 + 1}{2} \right) = \left(\frac{9 - 15}{2}, \frac{11 + 1}{2} \right) = \left(\frac{-6}{2}, \frac{12}{2} \right) = (-3, 6)$$

The equation of the perpendicular bisector of BC is

$$y - y_1 = m(x - x_1)$$

$$y - 6 = \frac{-12}{5} \left[x - (-3) \right]$$

$$y - 6 = \frac{-12}{5} \left(x + 3 \right)$$

$$y - 6 = \frac{-12}{5}x - \frac{36}{5}$$

$$y = \frac{-12}{5}x - \frac{6}{5}$$

(3) Solving $y = \frac{-12}{5}x - \frac{6}{5}$ and $y = \frac{3}{2}x + \frac{21}{2}$ simultaneously:

$$\frac{3}{2}x + \frac{21}{2} = \frac{-12}{5}x - \frac{6}{5}$$

$$\frac{3}{2}x + \frac{12}{5}x = \frac{-6}{5} - \frac{21}{2}$$

$$\frac{39}{10}x = -\frac{117}{10}$$

$$39x = -117$$

$$x = -3$$

Substitute $x = -3$ into $y = \frac{3}{2}x + \frac{21}{2}$:

$$y = \frac{3}{2} \left(-3 \right) + \frac{21}{2}$$

$$y = \frac{-9}{2} + \frac{21}{2}$$

$$y = \frac{12}{2}$$

$$y = 6$$

Check.

Substitute $x = -3$ and $y = 6$ into $y = \frac{-12}{5}x - \frac{6}{5}$:

$$\left(\begin{array}{c} 6 \\ 6 \end{array} \right) = \frac{-12}{5} \left(\begin{array}{c} -3 \\ -3 \end{array} \right) - \frac{6}{5}$$

$$6 = \frac{36}{5} - \frac{6}{5}$$

$$6 = \frac{30}{5}$$

$$6 = 6 \quad \checkmark$$

The centre of the circle is $(-3, 6)$

Solutionbank C2

Edexcel Modular Mathematics for AS and A-Level

Coordinate geometry in the (x,y) plane

Exercise C, Question 1

Question:

Find the distance between these pairs of points:

- (a) $(0, 1)$, $(6, 9)$
- (b) $(4, -6)$, $(9, 6)$
- (c) $(3, 1)$, $(-1, 4)$
- (d) $(3, 5)$, $(4, 7)$
- (e) $(2, 9)$, $(4, 3)$
- (f) $(0, -4)$, $(5, 5)$
- (g) $(-2, -7)$, $(5, 1)$
- (h) $(-4a, 0)$, $(3a, -2a)$
- (i) $(-b, 4b)$, $(-4b, -2b)$
- (j) $(2c, c)$, $(6c, 4c)$
- (k) $(-4d, d)$, $(2d, -4d)$
- (l) $(-e, -e)$, $(-3e, -5e)$
- (m) $(3\sqrt{2}, 6\sqrt{2})$, $(2\sqrt{2}, 4\sqrt{2})$
- (n) $(-\sqrt{3}, 2\sqrt{3})$, $(3\sqrt{3}, 5\sqrt{3})$
- (o) $(2\sqrt{3} - \sqrt{2}, \sqrt{5} + \sqrt{3})$, $(4\sqrt{3} - \sqrt{2}, 3\sqrt{5} + \sqrt{3})$

Solution:

$$\begin{aligned}
 \text{(a) } (x_1, y_1) &= (0, 1), (x_2, y_2) = (6, 9) \\
 &= \sqrt{(x_2 - x_1)^2 + (y_2 - y_1)^2} \\
 &= \sqrt{(6 - 0)^2 + (9 - 1)^2} \\
 &= \sqrt{6^2 + 8^2} \\
 &= \sqrt{36 + 64} \\
 &= \sqrt{100} \\
 &= 10
 \end{aligned}$$

$$\begin{aligned}
 \text{(b) } (x_1, y_1) &= (4, -6), (x_2, y_2) = (9, 6) \\
 &= \sqrt{(x_2 - x_1)^2 + (y_2 - y_1)^2} \\
 &= \sqrt{(9 - 4)^2 + [6 - (-6)]^2} \\
 &= \sqrt{5^2 + 12^2} \\
 &= \sqrt{25 + 144} \\
 &= \sqrt{169} \\
 &= 13
 \end{aligned}$$

$$(c) (x_1, y_1) = (3, 1), (x_2, y_2) = (-1, 4)$$

$$\begin{aligned} & \sqrt{(x_2 - x_1)^2 + (y_2 - y_1)^2} \\ &= \sqrt{(-1 - 3)^2 + (4 - 1)^2} \\ &= \sqrt{(-4)^2 + 3^2} \\ &= \sqrt{16 + 9} \\ &= \sqrt{25} \\ &= 5 \end{aligned}$$

$$(d) (x_1, y_1) = (3, 5), (x_2, y_2) = (4, 7)$$

$$\begin{aligned} & \sqrt{(x_2 - x_1)^2 + (y_2 - y_1)^2} \\ &= \sqrt{(4 - 3)^2 + (7 - 5)^2} \\ &= \sqrt{1^2 + 2^2} \\ &= \sqrt{1 + 4} \\ &= \sqrt{5} \end{aligned}$$

$$(e) (x_1, y_1) = (2, 9), (x_2, y_2) = (4, 3)$$

$$\begin{aligned} & \sqrt{(x_2 - x_1)^2 + (y_2 - y_1)^2} \\ &= \sqrt{(4 - 2)^2 + (3 - 9)^2} \\ &= \sqrt{2^2 + (-6)^2} \\ &= \sqrt{4 + 36} \\ &= \sqrt{40} \\ &= \sqrt{4 \times 10} \\ &= \sqrt{4} \times \sqrt{10} \\ &= 2\sqrt{10} \end{aligned}$$

$$(f) (x_1, y_1) = (0, -4), (x_2, y_2) = (5, 5)$$

$$\begin{aligned} & \sqrt{(x_2 - x_1)^2 + (y_2 - y_1)^2} \\ &= \sqrt{(5 - 0)^2 + [5 - (-4)]^2} \\ &= \sqrt{5^2 + 9^2} \\ &= \sqrt{25 + 81} \\ &= \sqrt{106} \end{aligned}$$

$$(g) (x_1, y_1) = (-2, -7), (x_2, y_2) = (5, 1)$$

$$\begin{aligned} & \sqrt{(x_2 - x_1)^2 + (y_2 - y_1)^2} \\ &= \sqrt{[5 - (-2)]^2 + [1 - (-7)]^2} \\ &= \sqrt{(5 + 2)^2 + (1 + 7)^2} \\ &= \sqrt{7^2 + 8^2} \\ &= \sqrt{49 + 64} \\ &= \sqrt{113} \end{aligned}$$

$$(h) (x_1, y_1) = (-4a, 0), (x_2, y_2) = (3a, -2a)$$

$$\begin{aligned} & \sqrt{(x_2 - x_1)^2 + (y_2 - y_1)^2} \\ &= \sqrt{[3a - (-4a)]^2 + (-2a - 0)^2} \\ &= \sqrt{(3a + 4a)^2 + (-2a)^2} \\ &= \sqrt{(7a)^2 + (-2a)^2} \\ &= \sqrt{49a^2 + 4a^2} \\ &= \sqrt{53a^2} \\ &= \sqrt{53} \sqrt{a^2} \\ &= a\sqrt{53} \end{aligned}$$

$$(i) (x_1, y_1) = (-b, 4b), (x_2, y_2) = (-4b, -2b)$$

$$\begin{aligned} & \sqrt{(x_2 - x_1)^2 + (y_2 - y_1)^2} \\ &= \sqrt{[-4b - (-b)]^2 + (-2b - 4b)^2} \\ &= \sqrt{(-4b + b)^2 + (-6b)^2} \\ &= \sqrt{(-3b)^2 + (-6b)^2} \\ &= \sqrt{9b^2 + 36b^2} \\ &= \sqrt{45b^2} \end{aligned}$$

$$\begin{aligned}
 &= \sqrt{9 \times 5 \times b^2} \\
 &= \sqrt{9} \sqrt{5} \sqrt{b^2} \\
 &= 3b \sqrt{5}
 \end{aligned}$$

$$(j) (x_1, y_1) = (2c, c), (x_2, y_2) = (6c, 4c)$$

$$\begin{aligned}
 &\sqrt{(x_2 - x_1)^2 + (y_2 - y_1)^2} \\
 &= \sqrt{(6c - 2c)^2 + (4c - c)^2} \\
 &= \sqrt{(4c)^2 + (3c)^2} \\
 &= \sqrt{16c^2 + 9c^2} \\
 &= \sqrt{25c^2} \\
 &= \sqrt{25} \sqrt{c^2} \\
 &= 5c
 \end{aligned}$$

$$(k) (x_1, y_1) = (-4d, d), (x_2, y_2) = (2d, -4d)$$

$$\begin{aligned}
 &\sqrt{(x_2 - x_1)^2 + (y_2 - y_1)^2} \\
 &= \sqrt{[2d - (-4d)]^2 + (-4d - d)^2} \\
 &= \sqrt{(2d + 4d)^2 + (-5d)^2} \\
 &= \sqrt{(6d)^2 + (-5d)^2} \\
 &= \sqrt{36d^2 + 25d^2} \\
 &= \sqrt{61d^2} \\
 &= \sqrt{61} \sqrt{d^2} \\
 &= d\sqrt{61}
 \end{aligned}$$

$$(l) (x_1, y_1) = (-e, -e), (x_2, y_2) = (-3e, -5e)$$

$$\begin{aligned}
 &\sqrt{(x_2 - x_1)^2 + (y_2 - y_1)^2} \\
 &= \sqrt{[-3e - (-e)]^2 + [-5e - (-e)]^2} \\
 &= \sqrt{(-3e + e)^2 + (-5e + e)^2} \\
 &= \sqrt{(-2e)^2 + (-4e)^2} \\
 &= \sqrt{4e^2 + 16e^2} \\
 &= \sqrt{20e^2} \\
 &= \sqrt{4 \times 5 \times e^2} \\
 &= \sqrt{4} \times \sqrt{5} \times \sqrt{e^2} \\
 &= 2\sqrt{5}e
 \end{aligned}$$

$$(m) (x_1, y_1) = (3\sqrt{2}, 6\sqrt{2}), (x_2, y_2) = (2\sqrt{2}, 4\sqrt{2})$$

$$\begin{aligned}
 &\sqrt{(x_2 - x_1)^2 + (y_2 - y_1)^2} \\
 &= \sqrt{(2\sqrt{2} - 3\sqrt{2})^2 + (4\sqrt{2} - 6\sqrt{2})^2} \\
 &= \sqrt{(-\sqrt{2})^2 + (-2\sqrt{2})^2} \\
 &= \sqrt{2 + 8} \\
 &= \sqrt{10}
 \end{aligned}$$

$$(n) (x_1, y_1) = (-\sqrt{3}, 2\sqrt{3}), (x_2, y_2) = (3\sqrt{3}, 5\sqrt{3})$$

$$\begin{aligned}
 &\sqrt{(x_2 - x_1)^2 + (y_2 - y_1)^2} \\
 &= \sqrt{[3\sqrt{3} - (-\sqrt{3})]^2 + (5\sqrt{3} - 2\sqrt{3})^2} \\
 &= \sqrt{(3\sqrt{3} + \sqrt{3})^2 + (3\sqrt{3})^2} \\
 &= \sqrt{(4\sqrt{3})^2 + (3\sqrt{3})^2} \\
 &= \sqrt{48 + 27} \\
 &= \sqrt{75} \\
 &= \sqrt{25 \times 3} \\
 &= \sqrt{25} \times \sqrt{3} \\
 &= 5\sqrt{3}
 \end{aligned}$$

$$(o) (x_1, y_1) = (2\sqrt{3} - \sqrt{2}, \sqrt{5} + \sqrt{3}), (x_2, y_2) = (4\sqrt{3} - \sqrt{2}, 3\sqrt{5} + \sqrt{3})$$

$$\begin{aligned}
 &\sqrt{(x_2 - x_1)^2 + (y_2 - y_1)^2} \\
 &= \sqrt{[4\sqrt{3} - \sqrt{2} - (2\sqrt{3} - \sqrt{2})]^2 + [3\sqrt{5} + \sqrt{3} - (\sqrt{5} + \sqrt{3})]^2} \\
 &= \sqrt{(4\sqrt{3} - \sqrt{2} - 2\sqrt{3} + \sqrt{2})^2 + (3\sqrt{5} + \sqrt{3} - \sqrt{5} - \sqrt{3})^2} \\
 &= \sqrt{(2\sqrt{3})^2 + (2\sqrt{5})^2}
 \end{aligned}$$

$$\begin{aligned} &= \sqrt{12 + 20} \\ &= \sqrt{32} \\ &= \sqrt{16 \times 2} \\ &= \sqrt{16} \times \sqrt{2} \\ &= 4 \sqrt{2} \end{aligned}$$

© Pearson Education Ltd 2008

Solutionbank C2

Edexcel Modular Mathematics for AS and A-Level

Coordinate geometry in the (x,y) plane

Exercise C, Question 2

Question:

The point $(4, -3)$ lies on the circle centre $(-2, 5)$. Find the radius of the circle.

Solution:

$$(x_1, y_1) = (4, -3), (x_2, y_2) = (-2, 5)$$

$$\sqrt{(x_2 - x_1)^2 + (y_2 - y_1)^2}$$

$$= \sqrt{(-2 - 4)^2 + [5 - (-3)]^2}$$

$$= \sqrt{(-6)^2 + 8^2}$$

$$= \sqrt{36 + 64}$$

$$= \sqrt{100}$$

$$= 10$$

Radius of circle = 10.

© Pearson Education Ltd 2008

Solutionbank C2

Edexcel Modular Mathematics for AS and A-Level

Coordinate geometry in the (x,y) plane

Exercise C, Question 3

Question:

The point $(14, 9)$ is the centre of the circle radius 25. Show that $(-10, 2)$ lies on the circle.

Solution:

$$(x_1, y_1) = (-10, 2), (x_2, y_2) = (14, 9)$$

$$\begin{aligned} & \sqrt{(x_2 - x_1)^2 + (y_2 - y_1)^2} \\ &= \sqrt{[14 - (-10)]^2 + (9 - 2)^2} \\ &= \sqrt{24^2 + 7^2} \\ &= \sqrt{576 + 49} \\ &= \sqrt{625} \\ &= 25 \end{aligned}$$

So $(-10, 2)$ is on the circle.

Solutionbank C2

Edexcel Modular Mathematics for AS and A-Level

Coordinate geometry in the (x,y) plane

Exercise C, Question 4

Question:

The line MN is a diameter of a circle, where M and N are $(6, -4)$ and $(0, -2)$ respectively. Find the radius of the circle.

Solution:

$$\begin{aligned} (x_1, y_1) &= (6, -4), (x_2, y_2) = (0, -2) \\ &\sqrt{(x_2 - x_1)^2 + (y_2 - y_1)^2} \\ &= \sqrt{(0 - 6)^2 + [-2 - (-4)]^2} \\ &= \sqrt{(-6)^2 + (-2 + 4)^2} \\ &= \sqrt{(-6)^2 + (2)^2} \\ &= \sqrt{36 + 4} \\ &= \sqrt{40} \\ &= \sqrt{4 \times 10} \\ &= \sqrt{4} \times \sqrt{10} \\ &= 2\sqrt{10} \end{aligned}$$

The diameter has length $2\sqrt{10}$.

So the radius has length $\frac{2\sqrt{10}}{2} = \sqrt{10}$.

Solutionbank C2

Edexcel Modular Mathematics for AS and A-Level

Coordinate geometry in the (x,y) plane

Exercise C, Question 5

Question:

The line QR is a diameter of the circle centre C , where Q and R have coordinates $(11, 12)$ and $(-5, 0)$ respectively. The point P is $(13, 6)$.

- (a) Find the coordinates of C .
- (b) Show that P lies on the circle.

Solution:

(a) The mid-point of QR is

$$\left(\frac{x_1 + x_2}{2}, \frac{y_1 + y_2}{2} \right) = \left(\frac{11 + (-5)}{2}, \frac{12 + 0}{2} \right) = \left(\frac{11 - 5}{2}, \frac{12}{2} \right) = \left(\frac{6}{2}, \frac{12}{2} \right) = (3, 6)$$

(b) The radius of the circle is

$$\begin{aligned} & \sqrt{(x_2 - x_1)^2 + (y_2 - y_1)^2} \\ &= \sqrt{(11 - 3)^2 + (12 - 6)^2} \\ &= \sqrt{8^2 + 6^2} \\ &= \sqrt{64 + 36} \\ &= \sqrt{100} \\ &= 10 \end{aligned}$$

The distance between C and P is

$$\begin{aligned} & \sqrt{(x_2 - x_1)^2 + (y_2 - y_1)^2} \\ &= \sqrt{(13 - 3)^2 + (6 - 6)^2} \\ &= \sqrt{10^2 + 0^2} \\ &= \sqrt{10^2} \\ &= 10 \end{aligned}$$

So P is on the circle.

Solutionbank C2

Edexcel Modular Mathematics for AS and A-Level

Coordinate geometry in the (x,y) plane

Exercise C, Question 6

Question:

The points $(-3, 19)$, $(-15, 1)$ and $(9, 1)$ are vertices of a triangle. Show that a circle centre $(-3, 6)$ can be drawn through the vertices of the triangle.

Solution:

$$(1) (x_1, y_1) = (-3, 6), (x_2, y_2) = (-3, 19)$$

$$\begin{aligned} & \sqrt{(x_2 - x_1)^2 + (y_2 - y_1)^2} \\ &= \sqrt{[(-3) - (-3)]^2 + (19 - 6)^2} \\ &= \sqrt{(-3 + 3)^2 + (13)^2} \\ &= \sqrt{0^2 + 13^2} \\ &= \sqrt{13^2} \\ &= 13 \end{aligned}$$

$$(2) (x_1, y_1) = (-3, 6), (x_2, y_2) = (-15, 1)$$

$$\begin{aligned} & \sqrt{(x_2 - x_1)^2 + (y_2 - y_1)^2} \\ &= \sqrt{[-15 - (-3)]^2 + (1 - 6)^2} \\ &= \sqrt{(-12)^2 + (-5)^2} \\ &= \sqrt{144 + 25} \\ &= \sqrt{169} \\ &= 13 \end{aligned}$$

$$(3) (x_1, y_1) = (-3, 6), (x_2, y_2) = (9, 1)$$

$$\begin{aligned} & \sqrt{(x_2 - x_1)^2 + (y_2 - y_1)^2} \\ &= \sqrt{[9 - (-3)]^2 + (1 - 6)^2} \\ &= \sqrt{(12)^2 + (-5)^2} \\ &= \sqrt{144 + 25} \\ &= \sqrt{169} \\ &= 13 \end{aligned}$$

The distance of each vertex of the triangle to $(-3, 6)$ is 13. So a circle centre $(-3, 6)$ and radius 13 can be drawn through the vertices of the triangle.

Solutionbank C2

Edexcel Modular Mathematics for AS and A-Level

Coordinate geometry in the (x,y) plane

Exercise C, Question 7

Question:

The line ST is a diameter of the circle c_1 , where S and T are $(5, 3)$ and $(-3, 7)$ respectively.

The line UV is a diameter of the circle c_2 centre $(4, 4)$. The point U is $(1, 8)$.

(a) Find the radius of (i) c_1 (ii) c_2 .

(b) Find the distance between the centres of c_1 and c_2 .

Solution:

(a) (i) The centre of c_1 is

$$\left(\frac{x_1 + x_2}{2}, \frac{y_1 + y_2}{2} \right) = \left(\frac{5 + (-3)}{2}, \frac{3 + 7}{2} \right) = \left(\frac{2}{2}, \frac{10}{2} \right) = (1, 5)$$

The radius of c_1 is

$$\begin{aligned} & \sqrt{(x_2 - x_1)^2 + (y_2 - y_1)^2} \\ &= \sqrt{(5 - 1)^2 + (3 - 5)^2} \\ &= \sqrt{4^2 + (-2)^2} \\ &= \sqrt{16 + 4} \\ &= \sqrt{20} \\ &= \sqrt{4 \times 5} \\ &= \sqrt{4} \times \sqrt{5} \\ &= 2\sqrt{5} \end{aligned}$$

(ii) The radius of c_2 is

$$\begin{aligned} & \sqrt{(x_2 - x_1)^2 + (y_2 - y_1)^2} \\ &= \sqrt{(4 - 1)^2 + (4 - 8)^2} \\ &= \sqrt{3^2 + (-4)^2} \\ &= \sqrt{9 + 16} \\ &= \sqrt{25} \\ &= 5 \end{aligned}$$

(b) The distance between the centres is

$$\begin{aligned} & \sqrt{(x_2 - x_1)^2 + (y_2 - y_1)^2} \\ &= \sqrt{(1 - 4)^2 + (5 - 4)^2} \\ &= \sqrt{(-3)^2 + (1)^2} \\ &= \sqrt{9 + 1} \\ &= \sqrt{10} \end{aligned}$$

Solutionbank C2

Edexcel Modular Mathematics for AS and A-Level

Coordinate geometry in the (x,y) plane

Exercise C, Question 8

Question:

The points $U(-2, 8)$, $V(7, 7)$ and $W(-3, -1)$ lie on a circle.

- (a) Show that $\triangle UVW$ has a right angle.
 (b) Find the coordinates of the centre of the circle.

Solution:

(a) (1) The distance UV is

$$\begin{aligned} & \sqrt{(x_2 - x_1)^2 + (y_2 - y_1)^2} \\ &= \sqrt{|7 - (-2)|^2 + (7 - 8)^2} \\ &= \sqrt{(7 + 2)^2 + (-1)^2} \\ &= \sqrt{9^2 + (-1)^2} \\ &= \sqrt{81 + 1} \\ &= \sqrt{82} \end{aligned}$$

(2) The distance VW is

$$\begin{aligned} & \sqrt{(x_2 - x_1)^2 + (y_2 - y_1)^2} \\ &= \sqrt{(-3 - 7)^2 + (-1 - 7)^2} \\ &= \sqrt{(-10)^2 + (-8)^2} \\ &= \sqrt{100 + 64} \\ &= \sqrt{164} \end{aligned}$$

(3) The distance UW is

$$\begin{aligned} & \sqrt{(x_2 - x_1)^2 + (y_2 - y_1)^2} \\ &= \sqrt{|-3 - (-2)|^2 + (-1 - 8)^2} \\ &= \sqrt{(-3 + 2)^2 + (-9)^2} \\ &= \sqrt{(-1)^2 + (-9)^2} \\ &= \sqrt{1 + 81} \\ &= \sqrt{82} \end{aligned}$$

$$\text{Now } (\sqrt{82})^2 + (\sqrt{82})^2 = (\sqrt{164})^2$$

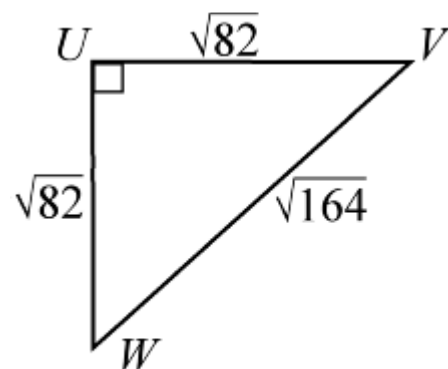

$$\text{i.e. } UV^2 + UW^2 = VW^2$$

So, by Pythagoras' theorem, $\triangle UVW$ has a right angle at U .

- (b) The angle in a semicircle is a right angle. So VW is a diameter of the circle.
 The mid-point of VW is

$$\left(\frac{x_1 + x_2}{2}, \frac{y_1 + y_2}{2} \right) = \left(\frac{7 + (-3)}{2}, \frac{7 + (-1)}{2} \right) = \left(\frac{7-3}{2}, \frac{7-1}{2} \right) = (2, 3)$$

The centre of the circle is $(2, 3)$.

© Pearson Education Ltd 2008

Solutionbank C2

Edexcel Modular Mathematics for AS and A-Level

Coordinate geometry in the (x,y) plane

Exercise C, Question 9

Question:

The points $A(2, 6)$, $B(5, 7)$ and $C(8, -2)$ lie on a circle.

- (a) Show that $\triangle ABC$ has a right angle.
 (b) Find the area of the triangle.

Solution:

(a) (1) The distance AB is

$$\begin{aligned} & \sqrt{(x_2 - x_1)^2 + (y_2 - y_1)^2} \\ &= \sqrt{(5 - 2)^2 + (7 - 6)^2} \\ &= \sqrt{3^2 + 1^2} \\ &= \sqrt{9 + 1} \\ &= \sqrt{10} \end{aligned}$$

(2) The distance BC is

$$\begin{aligned} & \sqrt{(x_2 - x_1)^2 + (y_2 - y_1)^2} \\ &= \sqrt{(8 - 5)^2 + (-2 - 7)^2} \\ &= \sqrt{3^2 + (-9)^2} \\ &= \sqrt{9 + 81} \\ &= \sqrt{90} \end{aligned}$$

(3) The distance AC is

$$\begin{aligned} & \sqrt{(x_2 - x_1)^2 + (y_2 - y_1)^2} \\ &= \sqrt{(8 - 2)^2 + (-2 - 6)^2} \\ &= \sqrt{6^2 + (-8)^2} \\ &= \sqrt{36 + 64} \\ &= \sqrt{100} \end{aligned}$$

$$\text{Now } (\sqrt{10})^2 + (\sqrt{90})^2 = (\sqrt{100})^2$$

$$\text{i.e. } AB^2 + BC^2 = AC^2$$

So, by Pythagoras' theorem, there is a right angle at B .

(b) The area of the triangle is

$$\frac{1}{2} \times \text{base} \times \text{height} = \frac{1}{2} \times AB \times BC = \frac{1}{2} \sqrt{10} \sqrt{90} = \frac{1}{2} \sqrt{900} = \frac{1}{2} \times 30 = 15$$

Solutionbank C2

Edexcel Modular Mathematics for AS and A-Level

Coordinate geometry in the (x,y) plane

Exercise C, Question 10

Question:

The points $A(-1, 9)$, $B(6, 10)$, $C(7, 3)$ and $D(0, 2)$ lie on a circle.

(a) Show that $ABCD$ is a square.

(b) Find the area of $ABCD$.

(c) Find the centre of the circle.

Solution:

(a) (1) The length of AB is

$$\begin{aligned} & \sqrt{(x_2 - x_1)^2 + (y_2 - y_1)^2} \\ &= \sqrt{[6 - (-1)]^2 + (10 - 9)^2} \\ &= \sqrt{7^2 + 1^2} \\ &= \sqrt{49 + 1} \\ &= \sqrt{50} \end{aligned}$$

(2) The length of BC is

$$\begin{aligned} & \sqrt{(x_2 - x_1)^2 + (y_2 - y_1)^2} \\ &= \sqrt{(7 - 6)^2 + (3 - 10)^2} \\ &= \sqrt{1^2 + (-7)^2} \\ &= \sqrt{1 + 49} \\ &= \sqrt{50} \end{aligned}$$

(3) The length of CD is

$$\begin{aligned} & \sqrt{(x_2 - x_1)^2 + (y_2 - y_1)^2} \\ &= \sqrt{(0 - 7)^2 + (2 - 3)^2} \\ &= \sqrt{(-7)^2 + (-1)^2} \\ &= \sqrt{49 + 1} \\ &= \sqrt{50} \end{aligned}$$

(4) The length of DA is

$$\begin{aligned} & \sqrt{(x_2 - x_1)^2 + (y_2 - y_1)^2} \\ &= \sqrt{(-1 - 0)^2 + (9 - 2)^2} \\ &= \sqrt{(-1)^2 + 7^2} \\ &= \sqrt{1 + 49} \\ &= \sqrt{50} \end{aligned}$$

The sides of the quadrilateral are equal.

(5) The gradient of AB is

$$\frac{y_2 - y_1}{x_2 - x_1} = \frac{10 - 9}{6 - (-1)} = \frac{1}{7}$$

The gradient of BC is

$$\frac{y_2 - y_1}{x_2 - x_1} = \frac{3 - 10}{7 - 6} = \frac{-7}{1} = -7$$

The product of the gradients = -1 $\left(\frac{1}{7} \times -7 = -1 \right)$.

So the line AB is perpendicular to BC .

So the quadrilateral $ABCD$ is a square.

(b) The area = $\sqrt{50} \times \sqrt{50} = 50$

(c) The mid-point of AC is

$$\left(\frac{x_1 + x_2}{2}, \frac{y_1 + y_2}{2} \right) = \left(\frac{-1 + 7}{2}, \frac{9 + 3}{2} \right) = \left(\frac{6}{2}, \frac{12}{2} \right) = (3, 6)$$

So the centre of the circle is $(3, 6)$.

© Pearson Education Ltd 2008

Solutionbank C2

Edexcel Modular Mathematics for AS and A-Level

Coordinate geometry in the (x,y) plane

Exercise D, Question 1

Question:

Write down the equation of these circles:

- (a) Centre $(3, 2)$, radius 4
- (b) Centre $(-4, 5)$, radius 6
- (c) Centre $(5, -6)$, radius $2\sqrt{3}$
- (d) Centre $(2a, 7a)$, radius $5a$
- (e) Centre $(-2\sqrt{2}, -3\sqrt{2})$, radius 1

Solution:

- (a) $(x_1, y_1) = (3, 2)$, $r = 4$
 So $(x - 3)^2 + (y - 2)^2 = 4^2$
 or $(x - 3)^2 + (y - 2)^2 = 16$
- (b) $(x_1, y_1) = (-4, 5)$, $r = 6$
 So $[x - (-4)]^2 + (y - 5)^2 = 6^2$
 or $(x + 4)^2 + (y - 5)^2 = 36$
- (c) $(x_1, y_1) = (5, -6)$, $r = 2\sqrt{3}$
 So $(x - 5)^2 + [y - (-6)]^2 = (2\sqrt{3})^2$
 $(x - 5)^2 + (y + 6)^2 = 2^2(\sqrt{3})^2$
 $(x - 5)^2 + (y + 6)^2 = 4 \times 3$
 $(x - 5)^2 + (y + 6)^2 = 12$
- (d) $(x_1, y_1) = (2a, 7a)$, $r = 5a$
 So $(x - 2a)^2 + (y - 7a)^2 = (5a)^2$
 or $(x - 2a)^2 + (y - 7a)^2 = 25a^2$
- (e) $(x_1, y_1) = (-2\sqrt{2}, -3\sqrt{2})$, $r = 1$
 So $[x - (-2\sqrt{2})]^2 + [y - (-3\sqrt{2})]^2 = 1^2$
 or $(x + 2\sqrt{2})^2 + (y + 3\sqrt{2})^2 = 1$

Solutionbank C2

Edexcel Modular Mathematics for AS and A-Level

Coordinate geometry in the (x,y) plane

Exercise D, Question 2

Question:

Write down the coordinates of the centre and the radius of these circles:

(a) $(x + 5)^2 + (y - 4)^2 = 9^2$

(b) $(x - 7)^2 + (y - 1)^2 = 16$

(c) $(x + 4)^2 + y^2 = 25$

(d) $(x + 4a)^2 + (y + a)^2 = 144a^2$

(e) $(x - 3\sqrt{5})^2 + (y + \sqrt{5})^2 = 27$

Solution:

(a) $(x + 5)^2 + (y - 4)^2 = 9^2$

or $[x - (-5)]^2 + (y - 4)^2 = 9^2$

The centre of the circle is $(-5, 4)$ and the radius is 9.

(b) $(x - 7)^2 + (y - 1)^2 = 16$

or $(x - 7)^2 + (y - 1)^2 = 4^2$

The centre of the circle is $(7, 1)$ and the radius is 4.

(c) $(x + 4)^2 + y^2 = 25$

or $[x - (-4)]^2 + (y - 0)^2 = 5^2$

The centre of the circle is $(-4, 0)$ and the radius is 5.

(d) $(x + 4a)^2 + (y + a)^2 = 144a^2$

or $[x - (-4a)]^2 + [y - (-a)]^2 = (12a)^2$

The centre of the circle is $(-4a, -a)$ and the radius is $12a$.

(e) $(x - 3\sqrt{5})^2 + (y + \sqrt{5})^2 = 27$

or $(x - 3\sqrt{5})^2 + [y - (-\sqrt{5})]^2 = (\sqrt{27})^2$

Now $\sqrt{27} = \sqrt{9 \times 3} = \sqrt{9} \times \sqrt{3} = 3\sqrt{3}$

The centre of the circle is $(3\sqrt{5}, -\sqrt{5})$ and the radius is $3\sqrt{3}$.

Solutionbank C2

Edexcel Modular Mathematics for AS and A-Level

Coordinate geometry in the (x,y) plane

Exercise D, Question 3

Question:

Find the centre and radius of these circles by first writing in the form $(x - a)^2 + (y - b)^2 = r^2$

(a) $x^2 + y^2 + 4x + 9y + 3 = 0$

(b) $x^2 + y^2 + 5x - 3y - 8 = 0$

(c) $2x^2 + 2y^2 + 8x + 15y - 1 = 0$

(d) $2x^2 + 2y^2 - 8x + 8y + 3 = 0$

Solution:

(a) $x^2 + y^2 + 4x + 9y + 3 = 0$

$$x^2 + 4x + y^2 + 9y = -3$$

$$(x + 2)^2 - 4 + \left(y + \frac{9}{2}\right)^2 - \frac{81}{4} = -3$$

$$(x + 2)^2 + \left(y + \frac{9}{2}\right)^2 = \frac{85}{4}$$

So the centre is $(-2, -4.5)$ and the radius is 4.61 (2 d.p.)

(b) $x^2 + y^2 + 5x - 3y - 8 = 0$

$$x^2 + 5x + y^2 - 3y = 8$$

$$\left(x + \frac{5}{2}\right)^2 - \frac{25}{4} + \left(y - \frac{3}{2}\right)^2 - \frac{9}{4} = 8$$

$$\left(x + \frac{5}{2}\right)^2 + \left(y - \frac{3}{2}\right)^2 = 16.5$$

So the centre is $(-2.5, 1.5)$ and the radius is 4.06 (2 d.p.)

(c) $2x^2 + 2y^2 + 8x + 15y - 1 = 0$

$$x^2 + y^2 + 4x + \frac{15}{2}y - \frac{1}{2} = 0$$

$$x^2 + 4x + y^2 + \frac{15}{2}y = \frac{1}{2}$$

$$(x + 2)^2 - 4 + \left(y + \frac{15}{4}\right)^2 - \frac{225}{16} = \frac{1}{2}$$

$$(x + 2)^2 + \left(y + \frac{15}{4}\right)^2 = 18\frac{9}{16}$$

So the centre is $(-2, -3.75)$ and the radius is 4.31 (2 d.p.)

(d) $2x^2 + 2y^2 - 8x + 8y + 3 = 0$

$$x^2 + y^2 - 4x + 4y + \frac{3}{2} = 0$$

$$x^2 - 4x + y^2 + 4y = -\frac{3}{2}$$

$$(x - 2)^2 - 4 + (y + 2)^2 - 4 = -\frac{3}{2}$$

$$(x - 2)^2 + (y + 2)^2 = \frac{13}{2}$$

So the centre is (2, -2) and the radius is 2.55 (2 d.p.)

© Pearson Education Ltd 2008

Solutionbank C2

Edexcel Modular Mathematics for AS and A-Level

Coordinate geometry in the (x,y) plane

Exercise D, Question 4

Question:

In each case, show that the circle passes through the given point:

(a) $(x - 2)^2 + (y - 5)^2 = 13$, $(4, 8)$

(b) $(x + 7)^2 + (y - 2)^2 = 65$, $(0, -2)$

(c) $x^2 + y^2 = 25^2$, $(7, -24)$

(d) $(x - 2a)^2 + (y + 5a)^2 = 20a^2$, $(6a, -3a)$

(e) $(x - 3\sqrt{5})^2 + (y - \sqrt{5})^2 = (2\sqrt{10})^2$, $(\sqrt{5}, -\sqrt{5})$

Solution:

(a) Substitute $x = 4$, $y = 8$ into $(x - 2)^2 + (y - 5)^2 = 13$
 $(x - 2)^2 + (y - 5)^2 = (4 - 2)^2 + (8 - 5)^2 = 2^2 + 3^2 = 4 + 9 = 13$ ✓
 So the circle passes through $(4, 8)$.

(b) Substitute $x = 0$, $y = -2$ into $(x + 7)^2 + (y - 2)^2 = 65$
 $(x + 7)^2 + (y - 2)^2 = (0 + 7)^2 + (-2 - 2)^2 = 7^2 + (-4)^2 = 49 + 16 = 65$ ✓
 So the circle passes through $(0, -2)$.

(c) Substitute $x = 7$ and $y = -24$ into $x^2 + y^2 = 25^2$
 $x^2 + y^2 = 7^2 + (-24)^2 = 49 + 576 = 625 = 25^2$ ✓
 So the circle passes through $(7, -24)$.

(d) Substitute $x = 6a$, $y = -3a$ into $(x - 2a)^2 + (y + 5a)^2 = 20a^2$
 $(x - 2a)^2 + (y + 5a)^2 = (6a - 2a)^2 + (-3a + 5a)^2 = (4a)^2 + (2a)^2 = 16a^2 + 4a^2 = 20a^2$ ✓
 So the circle passes through $(6a, -3a)$.

(e) Substitute $x = \sqrt{5}$, $y = -\sqrt{5}$ into $(x - 3\sqrt{5})^2 + (y - \sqrt{5})^2 = (2\sqrt{10})^2$
 $(x - 3\sqrt{5})^2 + (y - \sqrt{5})^2 = (\sqrt{5} - 3\sqrt{5})^2 + (-\sqrt{5} - \sqrt{5})^2 = (-2\sqrt{5})^2 + (-2\sqrt{5})^2$
 $= 4 \times 5 + 4 \times 5 = 20 + 20 = 40 = (2\sqrt{10})^2$
 Now $\sqrt{40} = \sqrt{4 \times 10} = \sqrt{4} \times \sqrt{10} = 2\sqrt{10}$ ✓
 So the circle passes through $(\sqrt{5}, -\sqrt{5})$.

Solutionbank C2

Edexcel Modular Mathematics for AS and A-Level

Coordinate geometry in the (x,y) plane
Exercise D, Question 5

Question:

The point (4 , - 2) lies on the circle centre (8 , 1) . Find the equation of the circle.

Solution:

The radius of the circle is

$$\begin{aligned} & \sqrt{(x_2 - x_1)^2 + (y_2 - y_1)^2} \\ &= \sqrt{(8 - 4)^2 + [1 - (-2)]^2} \\ &= \sqrt{4^2 + 3^2} \\ &= \sqrt{16 + 9} \\ &= \sqrt{25} \\ &= 5 \end{aligned}$$

The centre of the circle is (8 , 1) and the radius is 5.

$$\text{So } (x - 8)^2 + (y - 1)^2 = 5^2$$

$$\text{or } (x - 8)^2 + (y - 1)^2 = 25$$

© Pearson Education Ltd 2008

Solutionbank C2

Edexcel Modular Mathematics for AS and A-Level

Coordinate geometry in the (x,y) plane

Exercise D, Question 6

Question:

The line PQ is the diameter of the circle, where P and Q are $(5, 6)$ and $(-2, 2)$ respectively. Find the equation of the circle.

Solution:

(1) The centre of the circle is

$$\left(\frac{x_1 + x_2}{2}, \frac{y_1 + y_2}{2} \right) = \left(\frac{5 + (-2)}{2}, \frac{6 + 2}{2} \right) = \left(\frac{3}{2}, \frac{8}{2} \right) = \left(\frac{3}{2}, 4 \right)$$

(2) The radius of the circle is

$$\begin{aligned} & \sqrt{(x_2 - x_1)^2 + (y_2 - y_1)^2} \\ &= \sqrt{\left(5 - \frac{3}{2}\right)^2 + (6 - 4)^2} \\ &= \sqrt{\left(\frac{7}{2}\right)^2 + (2)^2} \\ &= \sqrt{\frac{49}{4} + 4} \\ &= \sqrt{\frac{49}{4} + \frac{16}{4}} \\ &= \sqrt{\frac{65}{4}} \end{aligned}$$

So the equation of the circle is

$$\left(x - \frac{3}{2}\right)^2 + (y - 4)^2 = \left(\sqrt{\frac{65}{4}}\right)^2$$

$$\text{or } \left(x - \frac{3}{2}\right)^2 + (y - 4)^2 = \frac{65}{4}$$

Solutionbank C2

Edexcel Modular Mathematics for AS and A-Level

Coordinate geometry in the (x,y) plane
Exercise D, Question 7

Question:

The point $(1, -3)$ lies on the circle $(x - 3)^2 + (y + 4)^2 = r^2$. Find the value of r .

Solution:

Substitute $x = 1, y = -3$ into $(x - 3)^2 + (y + 4)^2 = r^2$

$$(1 - 3)^2 + (-3 + 4)^2 = r^2$$

$$(-2)^2 + (1)^2 = r^2$$

$$4 + 1 = r^2$$

$$5 = r^2$$

$$\text{So } r = \sqrt{5}$$

© Pearson Education Ltd 2008

Solutionbank C2

Edexcel Modular Mathematics for AS and A-Level

Coordinate geometry in the (x,y) plane

Exercise D, Question 8

Question:

The line $y = 2x + 13$ touches the circle $x^2 + (y - 3)^2 = 20$ at $(-4, 5)$. Show that the radius at $(-4, 5)$ is perpendicular to the line.

Solution:

- (1) The centre of the circle $x^2 + (y - 3)^2 = 20$ is $(0, 3)$.
(2) The gradient of the line joining $(0, 3)$ and $(-4, 5)$ is

$$\frac{y_2 - y_1}{x_2 - x_1} = \frac{5 - 3}{-4 - 0} = \frac{2}{-4} = -\frac{1}{2}$$

- (3) The gradient of $y = 2x + 13$ is 2.
(4) The product of the gradients is

$$-\frac{1}{2} \times 2 = -1$$

So the radius is perpendicular to the line.

Solutionbank C2

Edexcel Modular Mathematics for AS and A-Level

Coordinate geometry in the (x,y) plane

Exercise D, Question 9

Question:

The line $x + 3y - 11 = 0$ touches the circle $(x + 1)^2 + (y + 6)^2 = 90$ at $(2, 3)$.

- (a) Find the radius of the circle.
- (b) Show that the radius at $(2, 3)$ is perpendicular to the line.

Solution:

(a) The radius of the circle $(x + 1)^2 + (y + 6)^2 = 90$ is $\sqrt{90}$.
 $\sqrt{90} = \sqrt{9 \times 10} = \sqrt{9} \times \sqrt{10} = 3\sqrt{10}$

(b) (1) The centre of the circle $(x + 1)^2 + (y + 6)^2 = 90$ is $(-1, -6)$.

(2) The gradient of the line joining $(-1, -6)$ and $(2, 3)$ is

$$\frac{y_2 - y_1}{x_2 - x_1} = \frac{3 - (-6)}{2 - (-1)} = \frac{3 + 6}{2 + 1} = \frac{9}{3} = 3$$

(3) Rearrange $x + 3y - 11 = 0$ into the form $y = mx + c$

$$x + 3y - 11 = 0$$

$$3y - 11 = -x$$

$$3y = -x + 11$$

$$y = -\frac{1}{3}x + \frac{11}{3}$$

So the gradient of $x + 3y - 11 = 0$ is $-\frac{1}{3}$.

(4) The product of the gradients is

$$3 \times -\frac{1}{3} = -1$$

So the radius is perpendicular to the line.

Solutionbank C2

Edexcel Modular Mathematics for AS and A-Level

Coordinate geometry in the (x,y) plane

Exercise D, Question 10

Question:

The point $P(1, -2)$ lies on the circle centre $(4, 6)$.

- (a) Find the equation of the circle.
 (b) Find the equation of the tangent to the circle at P .

Solution:

(a) (1) The radius of the circle is

$$\sqrt{(x_2 - x_1)^2 + (y_2 - y_1)^2} = \sqrt{(4 - 1)^2 + [6 - (-2)]^2} = \sqrt{3^2 + 8^2} = \sqrt{9 + 64} = \sqrt{73}$$

(2) The equation of the circle is

$$(x - 4)^2 + (y - 6)^2 = (\sqrt{73})^2$$

$$\text{or } (x - 4)^2 + (y - 6)^2 = 73$$

(b) (1) The gradient of the line joining $(1, -2)$ and $(4, 6)$ is

$$\frac{y_2 - y_1}{x_2 - x_1} = \frac{6 - (-2)}{4 - 1} = \frac{6 + 2}{3} = \frac{8}{3}$$

(2) The gradient of the tangent is $\frac{-1}{\left(\frac{8}{3}\right)} = -\frac{3}{8}$.

(3) The equation of the tangent to the circle at $(1, -2)$ is

$$y - y_1 = m(x - x_1)$$

$$y - \begin{pmatrix} -2 \end{pmatrix} = -\frac{3}{8} \begin{pmatrix} x - 1 \end{pmatrix}$$

$$y + 2 = -\frac{3}{8} \begin{pmatrix} x - 1 \end{pmatrix}$$

$$8y + 16 = -3(x - 1)$$

$$8y + 16 = -3x + 3$$

$$3x + 8y + 16 = 3$$

$$3x + 8y + 13 = 0$$

Solutionbank C2

Edexcel Modular Mathematics for AS and A-Level

Coordinate geometry in the (x,y) plane

Exercise E, Question 1

Question:

Find where the circle $(x - 1)^2 + (y - 3)^2 = 45$ meets the x -axis.

Solution:

Substitute $y = 0$ into $(x - 1)^2 + (y - 3)^2 = 45$

$$(x - 1)^2 + (-3)^2 = 45$$

$$(x - 1)^2 + 9 = 45$$

$$(x - 1)^2 = 36$$

$$x - 1 = \pm \sqrt{36}$$

$$x - 1 = \pm 6$$

$$\text{So } x - 1 = 6 \Rightarrow x = 7$$

$$\text{and } x - 1 = -6 \Rightarrow x = -5$$

The circle meets the x -axis at $(7, 0)$ and $(-5, 0)$.

Solutionbank C2

Edexcel Modular Mathematics for AS and A-Level

Coordinate geometry in the (x,y) plane

Exercise E, Question 2

Question:

Find where the circle $(x - 2)^2 + (y + 3)^2 = 29$ meets the y-axis.

Solution:

Substitute $x = 0$ into $(x - 2)^2 + (y + 3)^2 = 29$

$$(-2)^2 + (y + 3)^2 = 29$$

$$4 + (y + 3)^2 = 29$$

$$(y + 3)^2 = 25$$

$$y + 3 = \pm \sqrt{25}$$

$$y + 3 = \pm 5$$

$$\text{So } y + 3 = 5 \Rightarrow y = 2$$

$$\text{and } y + 3 = -5 \Rightarrow y = -8$$

The circle meets the y-axis at $(0, 2)$ and $(0, -8)$.

Solutionbank C2

Edexcel Modular Mathematics for AS and A-Level

Coordinate geometry in the (x,y) plane

Exercise E, Question 3

Question:

The circle $(x - 3)^2 + (y + 3)^2 = 34$ meets the x -axis at $(a, 0)$ and the y -axis at $(0, b)$. Find the possible values of a and b .

Solution:

(1) Substitute $x = a, y = 0$ into $(x - 3)^2 + (y + 3)^2 = 34$

$$(a - 3)^2 + (3)^2 = 34$$

$$(a - 3)^2 + 9 = 34$$

$$(a - 3)^2 = 25$$

$$a - 3 = \pm \sqrt{25}$$

$$a - 3 = \pm 5$$

$$\text{So } a - 3 = 5 \Rightarrow a = 8$$

$$\text{and } a - 3 = -5 \Rightarrow a = -2$$

The circle meets the x -axis at $(8, 0)$ and $(-2, 0)$.

(2) Substitute $x = 0, y = b$ into $(x - 3)^2 + (y + 3)^2 = 34$

$$(-3)^2 + (b + 3)^2 = 34$$

$$9 + (b + 3)^2 = 34$$

$$(b + 3)^2 = 25$$

$$b + 3 = \pm \sqrt{25}$$

$$b + 3 = \pm 5$$

$$\text{So } b + 3 = 5 \Rightarrow b = 2$$

$$\text{and } b + 3 = -5 \Rightarrow b = -8$$

The circle meets the y -axis at $(0, 2)$ and $(0, -8)$.

Solutionbank C2

Edexcel Modular Mathematics for AS and A-Level

Coordinate geometry in the (x,y) plane

Exercise E, Question 4

Question:

The line $y = x + 4$ meets the circle $(x - 3)^2 + (y - 5)^2 = 34$ at A and B . Find the coordinates of A and B .

Solution:

Substitute $y = x + 4$ into $(x - 3)^2 + (y - 5)^2 = 34$

$$(x - 3)^2 + [(x + 4) - 5]^2 = 34$$

$$(x - 3)^2 + (x + 4 - 5)^2 = 34$$

$$(x - 3)^2 + (x - 1)^2 = 34$$

$$x^2 - 6x + 9 + x^2 - 2x + 1 = 34$$

$$2x^2 - 8x + 10 = 34$$

$$2x^2 - 8x - 24 = 0$$

$$x^2 - 4x - 12 = 0$$

$$(x - 6)(x + 2) = 0$$

So $x = 6$ and $x = -2$

Substitute $x = 6$ into $y = x + 4$

$$y = 6 + 4$$

$$y = 10$$

Substitute $x = -2$ into $y = x + 4$

$$y = -2 + 4$$

$$y = 2$$

The coordinates of A and B are $(6, 10)$ and $(-2, 2)$.

Solutionbank C2

Edexcel Modular Mathematics for AS and A-Level

Coordinate geometry in the (x,y) plane

Exercise E, Question 5

Question:

Find where the line $x + y + 5 = 0$ meets the circle $(x + 3)^2 + (y + 5)^2 = 65$.

Solution:

Rearranging $x + y + 5 = 0$

$$y + 5 = -x$$

$$y = -x - 5$$

Substitute $y = -x - 5$ into $(x + 3)^2 + (y + 5)^2 = 65$

$$(x + 3)^2 + [(-x - 5) + 5]^2 = 65$$

$$(x + 3)^2 + (-x - 5 + 5)^2 = 65$$

$$(x + 3)^2 + (-x)^2 = 65$$

$$x^2 + 6x + 9 + x^2 = 65$$

$$2x^2 + 6x + 9 = 65$$

$$2x^2 + 6x - 56 = 0$$

$$x^2 + 3x - 28 = 0$$

$$(x + 7)(x - 4) = 0$$

$$\text{So } x = -7 \text{ and } x = 4$$

Substitute $x = -7$ into $y = -x - 5$

$$y = -(-7) - 5$$

$$y = 7 - 5$$

$$y = 2$$

Substitute $x = 4$ into $y = -x - 5$

$$y = -(4) - 5$$

$$y = -4 - 5$$

$$y = -9$$

So the line meets the circle at $(-7, 2)$ and $(4, -9)$.

Solutionbank C2

Edexcel Modular Mathematics for AS and A-Level

Coordinate geometry in the (x,y) plane
Exercise E, Question 6

Question:

Show that the line $y = x - 10$ does not meet the circle $(x - 2)^2 + y^2 = 25$.

Solution:

Substitute $y = x - 10$ into $(x - 2)^2 + y^2 = 25$

$$(x - 2)^2 + (x - 10)^2 = 25$$

$$x^2 - 4x + 4 + x^2 - 20x + 100 = 25$$

$$2x^2 - 24x + 104 = 25$$

$$2x^2 - 24x + 79 = 0$$

$$\text{Now } b^2 - 4ac = (-24)^2 - 4(2)(79) = 576 - 632 = -56$$

As $b^2 - 4ac < 0$ then $2x^2 - 24x + 79 = 0$ has no real roots.

So the line does not meet the circle.

© Pearson Education Ltd 2008

Solutionbank C2

Edexcel Modular Mathematics for AS and A-Level

Coordinate geometry in the (x,y) plane
Exercise E, Question 7

Question:

Show that the line $x + y = 11$ is a tangent to the circle $x^2 + (y - 3)^2 = 32$.

Solution:

Rearranging $x + y = 11$

$$y = 11 - x$$

Substitute $y = 11 - x$ into $x^2 + (y - 3)^2 = 32$

$$x^2 + [(11 - x) - 3]^2 = 32$$

$$x^2 + (11 - x - 3)^2 = 32$$

$$x^2 + (8 - x)^2 = 32$$

$$x^2 + 64 - 16x + x^2 = 32$$

$$2x^2 - 16x + 64 = 32$$

$$2x^2 - 16x + 32 = 0$$

$$x^2 - 8x + 16 = 0$$

$$(x - 4)(x - 4) = 0$$

The line meets the circle at $x = 4$ (only).

So the line is a tangent.

Solutionbank C2

Edexcel Modular Mathematics for AS and A-Level

Coordinate geometry in the (x,y) plane

Exercise E, Question 8

Question:

Show that the line $3x - 4y + 25 = 0$ is a tangent to the circle $x^2 + y^2 = 25$.

Solution:

Rearrange $3x - 4y + 25 = 0$

$$3x + 25 = 4y$$

$$4y = 3x + 25$$

$$y = \frac{3}{4}x + \frac{25}{4}$$

Substitute $y = \frac{3}{4}x + \frac{25}{4}$ into $x^2 + y^2 = 25$

$$x^2 + \left(\frac{3}{4}x + \frac{25}{4} \right)^2 = 25$$

$$x^2 + \frac{9}{16}x^2 + \frac{150}{16}x + \frac{625}{16} = 25$$

$$\frac{25}{16}x^2 + \frac{150}{16}x + \frac{225}{16} = 0$$

$$25x^2 + 150x + 225 = 0$$

$$x^2 + 6x + 9 = 0$$

$$(x + 3)(x + 3) = 0$$

The line meets the circle at $x = -3$ (only).

So the line is a tangent.

Solutionbank C2

Edexcel Modular Mathematics for AS and A-Level

Coordinate geometry in the (x,y) plane

Exercise E, Question 9

Question:

The line $y = 2x - 2$ meets the circle $(x - 2)^2 + (y - 2)^2 = 20$ at A and B .

- (a) Find the coordinates of A and B .
- (b) Show that AB is a diameter of the circle.

Solution:

(a) Substitute $y = 2x - 2$ into $(x - 2)^2 + (y - 2)^2 = 20$

$$(x - 2)^2 + [(2x - 2) - 2]^2 = 20$$

$$(x - 2)^2 + (2x - 4)^2 = 20$$

$$x^2 - 4x + 4 + 4x^2 - 16x + 16 = 20$$

$$5x^2 - 20x + 20 = 20$$

$$5x^2 - 20x = 0$$

$$5x(x - 4) = 0$$

So $x = 0$ and $x = 4$

Substitute $x = 0$ into $y = 2x - 2$

$$y = 2(0) - 2$$

$$y = 0 - 2$$

$$y = -2$$

Substitute $x = 4$ into $y = 2x - 2$

$$y = 2(4) - 2$$

$$y = 8 - 2$$

$$y = 6$$

So the coordinates of A and B are $(0, -2)$ and $(4, 6)$.

(b) (1) The length of AB is

$$\sqrt{(x_2 - x_1)^2 + (y_2 - y_1)^2}$$

$$= \sqrt{(4 - 0)^2 + [6 - (-2)]^2}$$

$$= \sqrt{4^2 + (6 + 2)^2}$$

$$= \sqrt{4^2 + 8^2}$$

$$= \sqrt{16 + 64}$$

$$= \sqrt{80}$$

$$= \sqrt{4 \times 20}$$

$$= \sqrt{4} \times \sqrt{20}$$

$$= 2\sqrt{20}$$

The radius of the circle $(x - 2)^2 + (y - 2)^2 = 20$ is $\sqrt{20}$.

So the length of the chord AB is twice the length of the radius.

AB is a diameter of the circle.

(2) Substitute $x = 2, y = 2$ into $y = 2x - 2$

$$2 = 2(2) - 2 = 4 - 2 = 2 \quad \checkmark$$

So the line $y = 2x - 2$ joining A and B passes through the centre $(2, 2)$ of the circle.

So AB is a diameter of the circle.

Solutionbank C2

Edexcel Modular Mathematics for AS and A-Level

Coordinate geometry in the (x,y) plane

Exercise E, Question 10

Question:

The line $x + y = a$ meets the circle $(x - p)^2 + (y - 6)^2 = 20$ at $(3, 10)$, where a and p are constants.

- (a) Work out the value of a .
- (b) Work out the two possible values of p .

Solution:

(a) Substitute $x = 3$, $y = 10$ into $x + y = a$
 $(3) + (10) = a$
So $a = 13$

(b) Substitute $x = 3$, $y = 10$ into $(x - p)^2 + (y - 6)^2 = 20$
 $(3 - p)^2 + (10 - 6)^2 = 20$
 $(3 - p)^2 + 4^2 = 20$
 $(3 - p)^2 + 16 = 20$
 $(3 - p)^2 = 4$
 $(3 - p) = \pm\sqrt{4}$
 $3 - p = \pm 2$
So $3 - p = 2 \Rightarrow p = 1$
and $3 - p = -2 \Rightarrow p = 5$

Solutionbank C2

Edexcel Modular Mathematics for AS and A-Level

Coordinate geometry in the (x,y) plane

Exercise F, Question 1

Question:

The line $y = 2x - 8$ meets the coordinate axes at A and B . The line AB is a diameter of the circle. Find the equation of the circle.

Solution:

Substitute $x = 0$ into $y = 2x - 8$

$$y = 2(0) - 8$$

$$y = -8$$

Substitute $y = 0$ into $y = 2x - 8$

$$0 = 2x - 8$$

$$2x = 8$$

$$x = 4$$

The line meets the coordinate axes at $(0, -8)$ and $(4, 0)$

The coordinates of the centre of the circle is

$$\left(\frac{x_1 + x_2}{2}, \frac{y_1 + y_2}{2} \right) = \left(\frac{0 + 4}{2}, \frac{-8 + 0}{2} \right) = \left(\frac{4}{2}, -\frac{8}{2} \right) = (2, -4)$$

The length of the diameter is

$$\begin{aligned} & \sqrt{(x_2 - x_1)^2 + (y_2 - y_1)^2} \\ &= \sqrt{(4 - 0)^2 + [0 - (-8)]^2} \\ &= \sqrt{4^2 + 8^2} \\ &= \sqrt{16 + 64} \\ &= \sqrt{80} \\ &= \sqrt{16 \times 5} \\ &= \sqrt{16} \times \sqrt{5} \\ &= 4\sqrt{5} \end{aligned}$$

So the length of the radius is $\frac{4\sqrt{5}}{2} = 2\sqrt{5}$.

The centre of the circle is $(2, -4)$ and the radius is $2\sqrt{5}$.

So the equation is

$$(x - x_1)^2 + (y - y_1)^2 = r^2$$

$$(x - 2)^2 + [y - (-4)]^2 = (2\sqrt{5})^2$$

$$(x - 2)^2 + (y + 4)^2 = 20$$

Solutionbank C2

Edexcel Modular Mathematics for AS and A-Level

Coordinate geometry in the (x,y) plane

Exercise F, Question 2

Question:

The circle centre $(8, 10)$ meets the x -axis at $(4, 0)$ and $(a, 0)$.

(a) Find the radius of the circle.

(b) Find the value of a .

Solution:

(a) The radius is

$$\begin{aligned} & \sqrt{(x_2 - x_1)^2 + (y_2 - y_1)^2} \\ &= \sqrt{(8 - 4)^2 + (10 - 0)^2} \\ &= \sqrt{4^2 + 10^2} \\ &= \sqrt{16 + 100} \\ &= \sqrt{116} \\ &= 2\sqrt{29} \end{aligned}$$

(b)

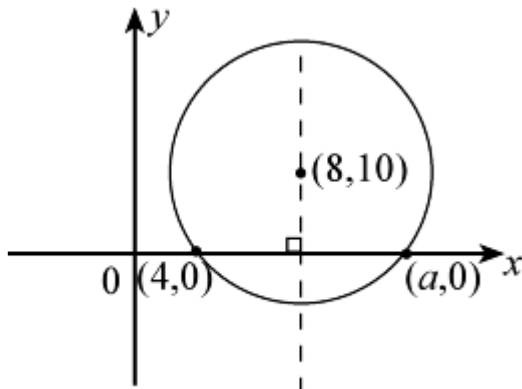

The centre is on the perpendicular bisector of $(4, 0)$ and $(a, 0)$. So

$$\frac{4+a}{2} = 8$$

$$4 + a = 16$$

$$a = 12$$

Solutionbank C2

Edexcel Modular Mathematics for AS and A-Level

Coordinate geometry in the (x,y) plane
Exercise F, Question 3

Question:

The circle $(x - 5)^2 + y^2 = 36$ meets the x -axis at P and Q . Find the coordinates of P and Q .

Solution:

Substitute $y = 0$ into $(x - 5)^2 + y^2 = 36$

$$(x - 5)^2 = 36$$

$$x - 5 = \sqrt{36}$$

$$x - 5 = \pm 6$$

$$\text{So } x - 5 = 6 \Rightarrow x = 11$$

$$\text{and } x - 5 = -6 \Rightarrow x = -1$$

The coordinates of P and Q are $(-1, 0)$ and $(11, 0)$.

© Pearson Education Ltd 2008

Solutionbank C2

Edexcel Modular Mathematics for AS and A-Level

Coordinate geometry in the (x,y) plane

Exercise F, Question 4

Question:

The circle $(x + 4)^2 + (y - 7)^2 = 121$ meets the y-axis at $(0, m)$ and $(0, n)$. Find the value of m and n .

Solution:

Substitute $x = 0$ into $(x + 4)^2 + (y - 7)^2 = 121$

$$4^2 + (y - 7)^2 = 121$$

$$16 + (y - 7)^2 = 121$$

$$(y - 7)^2 = 105$$

$$y - 7 = \pm \sqrt{105}$$

$$\text{So } y = 7 \pm \sqrt{105}$$

The values of m and n are $7 + \sqrt{105}$ and $7 - \sqrt{105}$.

Solutionbank C2

Edexcel Modular Mathematics for AS and A-Level

Coordinate geometry in the (x,y) plane

Exercise F, Question 5

Question:

The line $y = 0$ is a tangent to the circle $(x - 8)^2 + (y - a)^2 = 16$. Find the value of a .

Solution:

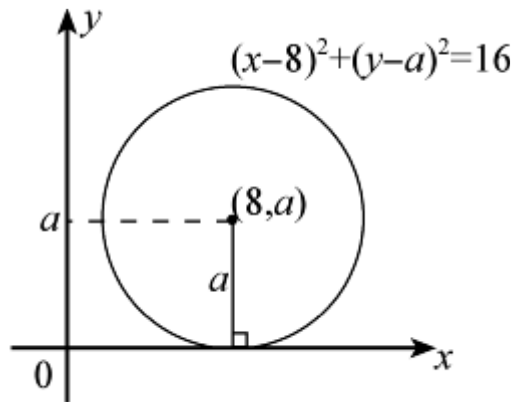

The radius of the circle is $\sqrt{16} = 4$.

So $a = 4$

© Pearson Education Ltd 2008

Solutionbank C2

Edexcel Modular Mathematics for AS and A-Level

Coordinate geometry in the (x,y) plane

Exercise F, Question 6

Question:

The point $A (-3, -7)$ lies on the circle centre $(5, 1)$.
Find the equation of the tangent to the circle at A .

Solution:

The gradient of the line joining $(-3, -7)$ and $(5, 1)$ is

$$\frac{y_2 - y_1}{x_2 - x_1} = \frac{1 - (-7)}{5 - (-3)} = \frac{1+7}{5+3} = \frac{8}{8} = 1$$

So the gradient of the tangent is $-\frac{1}{(1)} = -1$.

The equation of the tangent is

$$y - y_1 = m(x - x_1)$$

$$y - (-7) = -1[x - (-3)]$$

$$y + 7 = -1(x + 3)$$

$$y + 7 = -x - 3$$

$$y = -x - 10 \text{ or } x + y + 10 = 0$$

Solutionbank C2

Edexcel Modular Mathematics for AS and A-Level

Coordinate geometry in the (x,y) plane

Exercise F, Question 7

Question:

The circle $(x + 3)^2 + (y + 8)^2 = 100$ meets the positive coordinate axes at $A(a, 0)$ and $B(0, b)$.

(a) Find the value of a and b .

(b) Find the equation of the line AB .

Solution:

(a) Substitute $y = 0$ into $(x + 3)^2 + (y + 8)^2 = 100$

$$(x + 3)^2 + 8^2 = 100$$

$$(x + 3)^2 + 64 = 100$$

$$(x + 3)^2 = 36$$

$$x + 3 = \pm \sqrt{36}$$

$$x + 3 = \pm 6$$

$$\text{So } x + 3 = 6 \Rightarrow x = 3$$

$$\text{and } x + 3 = -6 \Rightarrow x = -9$$

As $a > 0$, $a = 3$.

Substitute $x = 0$ into $(x + 3)^2 + (y + 8)^2 = 100$

$$3^2 + (y + 8)^2 = 100$$

$$9 + (y + 8)^2 = 100$$

$$(y + 8)^2 = 91$$

$$y + 8 = \pm \sqrt{91}$$

$$\text{So } y + 8 = \sqrt{91} \Rightarrow y = \sqrt{91} - 8$$

$$\text{and } y + 8 = -\sqrt{91} \Rightarrow y = -\sqrt{91} - 8$$

As $b > 0$, $b = \sqrt{91} - 8$.

(b) The equation of the line joining $(3, 0)$ and $(0, \sqrt{91} - 8)$ is

$$\frac{y - y_1}{y_2 - y_1} = \frac{x - x_1}{x_2 - x_1}$$

$$\frac{y - 0}{(\sqrt{91} - 8) - 0} = \frac{x - 3}{0 - 3}$$

$$\frac{y}{\sqrt{91} - 8} = \frac{x - 3}{-3}$$

$$y = \left(\sqrt{91} - 8 \right) \times \left(\frac{x - 3}{-3} \right)$$

$$y = \left(\frac{\sqrt{91} - 8}{-3} \right) (x - 3)$$

$$y = \left(\frac{8 - \sqrt{91}}{3} \right) (x - 3)$$

Solutionbank C2

Edexcel Modular Mathematics for AS and A-Level

Coordinate geometry in the (x,y) plane

Exercise F, Question 8

Question:

The circle $(x + 2)^2 + (y - 5)^2 = 169$ meets the positive coordinate axes at $C(c, 0)$ and $D(0, d)$.

(a) Find the value of c and d .

(b) Find the area of $\triangle OCD$, where O is the origin.

Solution:

(a) Substitute $y = 0$ into $(x + 2)^2 + (y - 5)^2 = 169$

$$(x + 2)^2 + (-5)^2 = 169$$

$$(x + 2)^2 + 25 = 169$$

$$(x + 2)^2 = 144$$

$$x + 2 = \pm \sqrt{144}$$

$$x + 2 = \pm 12$$

$$\text{So } x + 2 = 12 \Rightarrow x = 10$$

$$\text{and } x + 2 = -12 \Rightarrow x = -14$$

As $c > 0$, $c = 10$.

Substitute $x = 0$ into $(x + 2)^2 + (y - 5)^2 = 169$

$$2^2 + (y - 5)^2 = 169$$

$$4 + (y - 5)^2 = 169$$

$$(y - 5)^2 = 165$$

$$y - 5 = \pm \sqrt{165}$$

$$\text{So } y - 5 = \sqrt{165} \Rightarrow y = \sqrt{165} + 5$$

$$\text{and } y - 5 = -\sqrt{165} \Rightarrow y = -\sqrt{165} + 5$$

As $d > 0$, $d = \sqrt{165} + 5$.

(b)

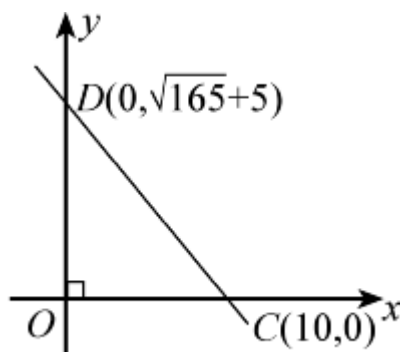

The area of $\triangle OCD$ is

$$\frac{1}{2} \times 10 \times \left(\sqrt{165} + 5 \right) = 5 \left(\sqrt{165} + 5 \right)$$

Solutionbank C2

Edexcel Modular Mathematics for AS and A-Level

Coordinate geometry in the (x,y) plane

Exercise F, Question 9

Question:

The circle, centre (p, q) radius 25, meets the x -axis at $(-7, 0)$ and $(7, 0)$, where $q > 0$.

- (a) Find the value of p and q .
- (b) Find the coordinates of the points where the circle meets the y -axis.

Solution:

- (a) By symmetry $p = 0$.

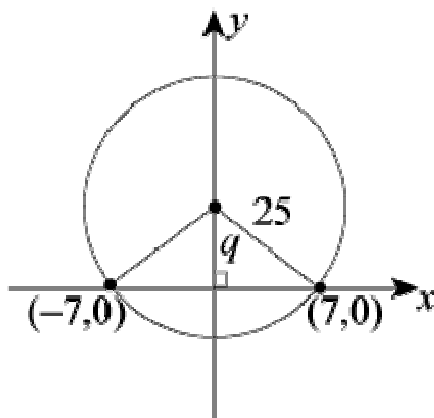

Using Pythagoras' theorem

$$q^2 + 7^2 = 25^2$$

$$q^2 + 49 = 625$$

$$q^2 = 576$$

$$q = \pm \sqrt{576}$$

$$q = \pm 24$$

As $q > 0$, $q = 24$.

- (b) The circle meets the y -axis at $q \pm r$; i.e.
 at $24 + 25 = 49$
 and $24 - 25 = -1$
 So the coordinates are $(0, 49)$ and $(0, -1)$.

Solutionbank C2

Edexcel Modular Mathematics for AS and A-Level

Coordinate geometry in the (x,y) plane
Exercise F, Question 10

Question:

Show that $(0, 0)$ lies inside the circle $(x - 5)^2 + (y + 2)^2 = 30$.

Solution:

The distance between $(0, 0)$ and $(5, -2)$ is

$$\begin{aligned} & \sqrt{(x_2 - x_1)^2 + (y_2 - y_1)^2} \\ &= \sqrt{(5 - 0)^2 + (-2 - 0)^2} \\ &= \sqrt{5^2 + (-2)^2} \\ &= \sqrt{25 + 4} \\ &= \sqrt{29} \end{aligned}$$

The radius of the circle is $\sqrt{30}$.

As $\sqrt{29} < \sqrt{30}$ $(0, 0)$ lies inside the circle.

© Pearson Education Ltd 2008

Solutionbank C2

Edexcel Modular Mathematics for AS and A-Level

Coordinate geometry in the (x,y) plane

Exercise F, Question 11

Question:

The points $A(-4, 0)$, $B(4, 8)$ and $C(6, 0)$ lie on a circle. The lines AB and BC are chords of the circle. Find the coordinates of the centre of the circle.

Solution:

(1) The gradient of AB is

$$\frac{y_2 - y_1}{x_2 - x_1} = \frac{8 - 0}{4 - (-4)} = \frac{8}{4 + 4} = \frac{8}{8} = 1$$

(2) The gradient of a line perpendicular to AB is $\frac{-1}{(1)} = -1$.

(3) The mid-point of AB is

$$\left(\frac{x_1 + x_2}{2}, \frac{y_1 + y_2}{2} \right) = \left(\frac{-4 + 4}{2}, \frac{0 + 8}{2} \right) = \left(\frac{0}{2}, \frac{8}{2} \right) = (0, 4)$$

(4) The equation of the perpendicular bisector of AB is

$$\begin{aligned} y - y_1 &= m(x - x_1) \\ y - 4 &= -1(x - 0) \\ y - 4 &= -x \\ y &= -x + 4 \end{aligned}$$

(5) The gradient of BC is

$$\frac{y_2 - y_1}{x_2 - x_1} = \frac{0 - 8}{6 - 4} = \frac{-8}{2} = -4$$

(6) The gradient of a line perpendicular to BC is $-\frac{1}{(-4)} = \frac{1}{4}$.

(7) The mid-point of BC is

$$\left(\frac{x_1 + x_2}{2}, \frac{y_1 + y_2}{2} \right) = \left(\frac{4 + 6}{2}, \frac{8 + 0}{2} \right) = \left(\frac{10}{2}, \frac{8}{2} \right) = (5, 4)$$

(8) The equation of the perpendicular bisector of BC is

$$\begin{aligned} y - y_1 &= m(x - x_1) \\ y - 4 &= \frac{1}{4}(x - 5) \\ y - 4 &= \frac{1}{4}x - \frac{5}{4} \\ y &= \frac{1}{4}x + \frac{11}{4} \end{aligned}$$

(9) Solving $y = -x + 4$ and $y = \frac{1}{4}x + \frac{11}{4}$ simultaneously

$$\frac{1}{4}x + \frac{11}{4} = -x + 4$$

$$\frac{5}{4}x + \frac{11}{4} = 4$$

$$\frac{5}{4}x = \frac{5}{4}$$

$$x = 1$$

Substitute $x = 1$ into $y = -x + 4$

$$y = -1 + 4$$

$$y = 3$$

So coordinates of the centre of the circle are $(1, 3)$.

© Pearson Education Ltd 2008

Solutionbank C2

Edexcel Modular Mathematics for AS and A-Level

Coordinate geometry in the (x,y) plane

Exercise F, Question 12

Question:

The points $R(-4, 3)$, $S(7, 4)$ and $T(8, -7)$ lie on a circle.

- (a) Show that $\triangle RST$ has a right angle.
 (b) Find the equation of the circle.

Solution:

(a) (1) The distance between R and S is

$$\begin{aligned} & \sqrt{(x_2 - x_1)^2 + (y_2 - y_1)^2} \\ &= \sqrt{[7 - (-4)]^2 + (4 - 3)^2} \\ &= \sqrt{(7 + 4)^2 + 1^2} \\ &= \sqrt{11^2 + 1^2} \\ &= \sqrt{121 + 1} \\ &= \sqrt{122} \end{aligned}$$

(2) The distance between S and T is

$$\begin{aligned} & \sqrt{(x_2 - x_1)^2 + (y_2 - y_1)^2} \\ &= \sqrt{(8 - 7)^2 + (-7 - 4)^2} \\ &= \sqrt{1^2 + (-11)^2} \\ &= \sqrt{1 + 121} \\ &= \sqrt{122} \end{aligned}$$

(3) The distance between R and T is

$$\begin{aligned} & \sqrt{(x_2 - x_1)^2 + (y_2 - y_1)^2} \\ &= \sqrt{[8 - (-4)]^2 + (-7 - 3)^2} \\ &= \sqrt{(8 + 4)^2 + (-10)^2} \\ &= \sqrt{12^2 + (-10)^2} \\ &= \sqrt{144 + 100} \\ &= \sqrt{244} \end{aligned}$$

By Pythagoras' theorem

$$(\sqrt{122})^2 + (\sqrt{122})^2 = (\sqrt{244})^2$$

So $\triangle RST$ has a right angle (at S).

(b) (1) The radius of the circle is

$$\frac{1}{2} \times \text{diameter} = \frac{1}{2} \sqrt{244} = \frac{1}{2} \sqrt{4 \times 61} = \frac{1}{2} \sqrt{4} \times \sqrt{61} = \frac{1}{2} \times 2 \sqrt{61} = \sqrt{61}$$

(2) The centre of the circle is the mid-point of RT :

$$\begin{aligned} & \left(\frac{x_1 + x_2}{2}, \frac{y_1 + y_2}{2} \right) \\ &= \left(\frac{-4 + 8}{2}, \frac{3 + (-7)}{2} \right) = \left(\frac{4}{2}, -\frac{4}{2} \right) = \left(2, -2 \right) \end{aligned}$$

So the equation of the circle is

$$(x - 2)^2 + (y + 2)^2 = (\sqrt{61})^2$$

$$\text{or } (x - 2)^2 + (y + 2)^2 = 61$$

Solutionbank C2

Edexcel Modular Mathematics for AS and A-Level

Coordinate geometry in the (x,y) plane

Exercise F, Question 13

Question:

The points $A(-7, 7)$, $B(1, 9)$, $C(3, 1)$ and $D(-7, 1)$ lie on a circle. The lines AB and CD are chords of the circle.

- (a) Find the equation of the perpendicular bisector of (i) AB (ii) CD .
- (b) Find the coordinates of the centre of the circle.

Solution:

(a) (i) (1) The gradient of the line joining A and B is

$$\frac{y_2 - y_1}{x_2 - x_1} = \frac{9 - 7}{1 - (-7)} = \frac{2}{1 + 7} = \frac{2}{8} = \frac{1}{4}$$

(2) The gradient of a line perpendicular to AB is $-\frac{1}{m} = \frac{-1}{\left(\frac{1}{4}\right)} = -4$

(3) The mid-point of AB is

$$\left(\frac{x_1 + x_2}{2}, \frac{y_1 + y_2}{2} \right) = \left(\frac{-7 + 1}{2}, \frac{7 + 9}{2} \right) = \left(\frac{-6}{2}, \frac{16}{2} \right) = (-3, 8)$$

(4) The equation of the perpendicular bisector of AB is

$$\begin{aligned} y - y_1 &= m(x - x_1) \\ y - 8 &= -4[x - (-3)] \\ y - 8 &= -4(x + 3) \\ y - 8 &= -4x - 12 \\ y &= -4x - 4 \end{aligned}$$

(ii) (1) The gradient of the line joining C and D is

$$\frac{y_2 - y_1}{x_2 - x_1} = \frac{1 - 1}{-7 - 3} = \frac{0}{-10} = 0$$

So the line is horizontal.

(2) The mid-point of CD is $\left(\frac{x_1 + x_2}{2}, \frac{y_1 + y_2}{2} \right) = \left(\frac{3 + (-7)}{2}, \frac{1 + 1}{2} \right) = \left(\frac{-4}{2}, \frac{2}{2} \right) = (-2, 1)$

(3) The equation of the perpendicular bisector of CD is $x = -2$
i.e. the vertical line through $(-2, 1)$

(b) Solving $y = -4x - 4$ and $x = -2$ simultaneously,
substitute $x = -2$ into $y = -4x - 4$
 $y = -4(-2) - 4 = 8 - 4 = 4$
So the centre of the circle is $(-2, 4)$.

Solutionbank C2

Edexcel Modular Mathematics for AS and A-Level

Coordinate geometry in the (x,y) plane

Exercise F, Question 14

Question:

The centres of the circles $(x - 8)^2 + (y - 8)^2 = 117$ and $(x + 1)^2 + (y - 3)^2 = 106$ are P and Q respectively.

(a) Show that P lies on $(x + 1)^2 + (y - 3)^2 = 106$.

(b) Find the length of PQ .

Solution:

(a) The centre of $(x - 8)^2 + (y - 8)^2 = 117$ is $(8, 8)$.

Substitute $(8, 8)$ into $(x + 1)^2 + (y - 3)^2 = 106$

$$(8 + 1)^2 + (8 - 3)^2 = 9^2 + 5^2 = 81 + 25 = 106 \quad \checkmark$$

So $(8, 8)$ lies on the circle $(x + 1)^2 + (y - 3)^2 = 106$.

(b) As Q is the centre of the circle $(x + 1)^2 + (y - 3)^2 = 106$ and P lies on this circle, the length PQ must equal the radius.

$$\text{So } PQ = \sqrt{106}$$

Solutionbank C2

Edexcel Modular Mathematics for AS and A-Level

Coordinate geometry in the (x,y) plane

Exercise F, Question 15

Question:

The line $y = -3x + 12$ meets the coordinate axes at A and B .

- Find the coordinates of A and B .
- Find the coordinates of the mid-point of AB .
- Find the equation of the circle that passes through A , B and O , where O is the origin.

Solution:

(a) $y = -3x + 12$

(1) Substitute $x = 0$ into $y = -3x + 12$

$$y = -3(0) + 12 = 12$$

So A is $(0, 12)$.

(2) Substitute $y = 0$ into $y = -3x + 12$

$$0 = -3x + 12$$

$$3x = 12$$

$$x = 4$$

So B is $(4, 0)$.

(b) The mid-point of AB is

$$\left(\frac{x_1 + x_2}{2}, \frac{y_1 + y_2}{2} \right) = \left(\frac{0 + 4}{2}, \frac{12 + 0}{2} \right) = (2, 6)$$

(c)

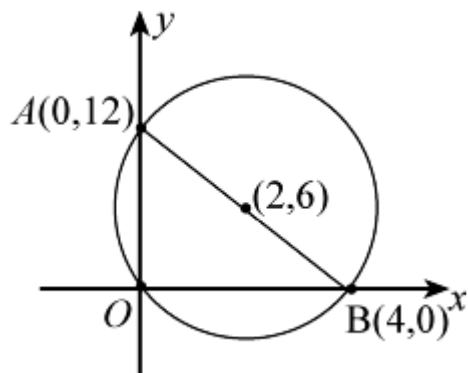

$\angle AOB = 90^\circ$, so AB is a diameter of the circle.

The centre of the circle is the mid-point of AB , i.e. $(2, 6)$.

The length of the diameter AB is

$$\begin{aligned} & \sqrt{(x_2 - x_1)^2 + (y_2 - y_1)^2} \\ &= \sqrt{(4 - 0)^2 + (0 - 12)^2} \\ &= \sqrt{4^2 + (-12)^2} \\ &= \sqrt{16 + 144} \\ &= \sqrt{160} \end{aligned}$$

So the radius of the circle is $\frac{\sqrt{160}}{2}$.

The equation of the circle is

$$(x - 2)^2 + (y - 6)^2 = \left(\frac{\sqrt{160}}{2} \right)^2$$

$$(x - 2)^2 + (y - 6)^2 = \frac{160}{4}$$

$$(x - 2)^2 + (y - 6)^2 = 40$$

© Pearson Education Ltd 2008

Solutionbank C2

Edexcel Modular Mathematics for AS and A-Level

Coordinate geometry in the (x,y) plane

Exercise F, Question 16

Question:

The points $A(-5, 5)$, $B(1, 5)$, $C(3, 3)$ and $D(3, -3)$ lie on a circle. Find the equation of the circle.

Solution:

(1)

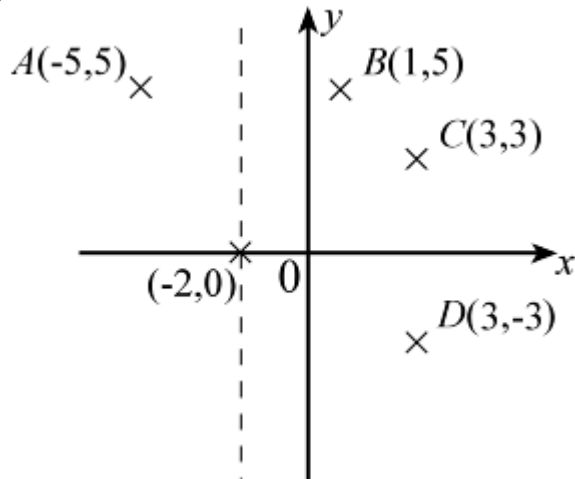

(2) The mid-point of AB is

$$\left(\frac{x_1 + x_2}{2}, \frac{y_1 + y_2}{2} \right) = \left(\frac{-5 + 1}{2}, \frac{5 + 5}{2} \right) = \left(\frac{-4}{2}, \frac{10}{2} \right) = (-2, 5)$$

So the equation of the perpendicular bisector of AB is $x = -2$.

(3) The mid-point of CD is

$$\left(\frac{x_1 + x_2}{2}, \frac{y_1 + y_2}{2} \right) = \left(\frac{3 + 3}{2}, \frac{3 + (-3)}{2} \right) = \left(\frac{6}{2}, \frac{3 - 3}{2} \right) = \left(3, \frac{0}{2} \right) = (3, 0)$$

So the equation of the perpendicular bisector of CD is $y = 0$.

(4) The perpendicular bisectors intersect at $(-2, 0)$.

(5) The radius is the distance between $(-2, 0)$ and $(-5, 5)$

$$\begin{aligned} & \sqrt{(x_2 - x_1)^2 + (y_2 - y_1)^2} \\ &= \sqrt{[-5 - (-2)]^2 + (5 - 0)^2} \\ &= \sqrt{(-5 + 2)^2 + (5)^2} \\ &= \sqrt{(-3)^2 + (5)^2} \\ &= \sqrt{9 + 25} \\ &= \sqrt{34} \end{aligned}$$

(6) So the equation of the circle centre $(-2, 0)$ and radius $\sqrt{34}$ is

$$\begin{aligned} [x - (-2)]^2 + (y - 0)^2 &= (\sqrt{34})^2 \\ (x + 2)^2 + y^2 &= 34 \end{aligned}$$

Solutionbank C2

Edexcel Modular Mathematics for AS and A-Level

Coordinate geometry in the (x,y) plane

Exercise F, Question 17

Question:

The line AB is a chord of a circle centre $(2, -1)$, where A and B are $(3, 7)$ and $(-5, 3)$ respectively. AC is a diameter of the circle. Find the area of $\triangle ABC$.

Solution:

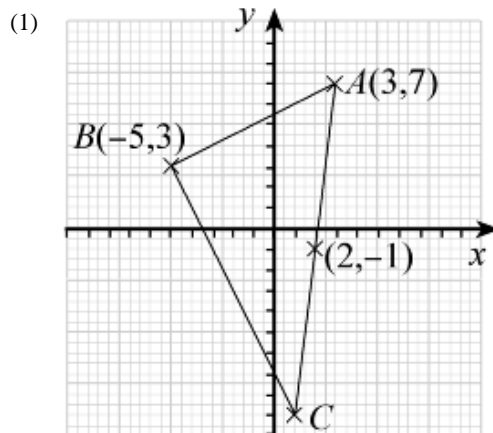

(2) Let the coordinates of C be (p, q) .

$(2, -1)$ is the mid-point of $(3, 7)$ and (p, q)

$$\text{So } \frac{3+p}{2} = 2 \text{ and } \frac{7+q}{2} = -1$$

$$\frac{3+p}{2} = 2$$

$$3+p=4$$

$$p=1$$

$$\frac{7+q}{2} = -1$$

$$7+q = -2$$

$$q = -9$$

So the coordinates of C are $(1, -9)$.

(3) The length of AB is

$$\begin{aligned} & \sqrt{(x_2 - x_1)^2 + (y_2 - y_1)^2} \\ &= \sqrt{(-5 - 3)^2 + (3 - 7)^2} \\ &= \sqrt{(-8)^2 + (-4)^2} \\ &= \sqrt{64 + 16} \\ &= \sqrt{80} \end{aligned}$$

The length of BC is

$$\begin{aligned} & \sqrt{(x_2 - x_1)^2 + (y_2 - y_1)^2} \\ &= \sqrt{(-5 - 1)^2 + [3 - (-9)]^2} \\ &= \sqrt{(-6)^2 + (3 + 9)^2} \\ &= \sqrt{(-6)^2 + (12)^2} \\ &= \sqrt{36 + 144} \\ &= \sqrt{180} \end{aligned}$$

(4) The area of $\triangle ABC$ is

$$\frac{1}{2} \sqrt{180} \sqrt{80} = \frac{1}{2} \sqrt{14400} = \frac{1}{2} \sqrt{144 \times 100} = \frac{1}{2} \sqrt{144} \times \sqrt{100} = \frac{1}{2} \times 12 \times 10 = 60$$

Solutionbank C2

Edexcel Modular Mathematics for AS and A-Level

Coordinate geometry in the (x,y) plane

Exercise F, Question 18

Question:

The points $A(-1, 0)$, $B\left(\frac{1}{2}, \frac{\sqrt{3}}{2}\right)$ and $C\left(\frac{1}{2}, -\frac{\sqrt{3}}{2}\right)$ are the vertices of a triangle.

(a) Show that the circle $x^2 + y^2 = 1$ passes through the vertices of the triangle.

(b) Show that $\triangle ABC$ is equilateral.

Solution:

(a) (1) Substitute $(-1, 0)$ into $x^2 + y^2 = 1$

$$(-1)^2 + (0)^2 = 1 + 0 = 1 \quad \checkmark$$

So $(-1, 0)$ is on the circle.

(2) Substitute $\left(\frac{1}{2}, \frac{\sqrt{3}}{2}\right)$ into $x^2 + y^2 = 1$

$$\left(\frac{1}{2}\right)^2 + \left(\frac{\sqrt{3}}{2}\right)^2 = \frac{1}{4} + \frac{3}{4} = 1 \quad \checkmark$$

So $\left(\frac{1}{2}, \frac{\sqrt{3}}{2}\right)$ is on the circle.

(3) Substitute $\left(\frac{1}{2}, -\frac{\sqrt{3}}{2}\right)$ into $x^2 + y^2 = 1$

$$\left(\frac{1}{2}\right)^2 + \left(-\frac{\sqrt{3}}{2}\right)^2 = \frac{1}{4} + \frac{3}{4} = 1 \quad \checkmark$$

So $\left(\frac{1}{2}, -\frac{\sqrt{3}}{2}\right)$ is on the circle.

(b) (1) The distance between $(-1, 0)$ and $\left(\frac{1}{2}, \frac{\sqrt{3}}{2}\right)$ is

$$\begin{aligned} & \sqrt{(x_2 - x_1)^2 + (y_2 - y_1)^2} \\ &= \sqrt{\left[\frac{1}{2} - (-1)\right]^2 + \left(\frac{\sqrt{3}}{2} - 0\right)^2} \\ &= \sqrt{\left(\frac{1}{2} + 1\right)^2 + \left(\frac{\sqrt{3}}{2}\right)^2} \\ &= \sqrt{\left(\frac{3}{2}\right)^2 + \left(\frac{\sqrt{3}}{2}\right)^2} \\ &= \sqrt{\frac{9}{4} + \frac{3}{4}} \end{aligned}$$

$$= \sqrt{\frac{12}{4}}$$

$$= \sqrt{3}$$

(2) The distance between $(-1, 0)$ and $\left(\frac{1}{2}, \frac{-\sqrt{3}}{2}\right)$ is

$$\sqrt{(x_2 - x_1)^2 + (y_2 - y_1)^2}$$

$$= \sqrt{\left[\frac{1}{2} - (-1)\right]^2 + \left(\frac{-\sqrt{3}}{2} - 0\right)^2}$$

$$= \sqrt{\left(\frac{1}{2} + 1\right)^2 + \left(\frac{-\sqrt{3}}{2}\right)^2}$$

$$= \sqrt{\left(\frac{3}{2}\right)^2 + \left(\frac{-\sqrt{3}}{2}\right)^2}$$

$$= \sqrt{\frac{9}{4} + \frac{3}{4}}$$

$$= \sqrt{\frac{12}{4}}$$

$$= \sqrt{3}$$

(3) The distance between $\left(\frac{1}{2}, \frac{\sqrt{3}}{2}\right)$ and $\left(\frac{1}{2}, \frac{-\sqrt{3}}{2}\right)$ is

$$\sqrt{(x_2 - x_1)^2 + (y_2 - y_1)^2}$$

$$= \sqrt{\left(\frac{1}{2} - \frac{1}{2}\right)^2 + \left(\frac{-\sqrt{3}}{2} - \frac{\sqrt{3}}{2}\right)^2}$$

$$= \sqrt{0^2 + (-\sqrt{3})^2}$$

$$= \sqrt{0 + 3}$$

$$= \sqrt{3}$$

So AB , BC and AC all equal $\sqrt{3}$.

$\triangle ABC$ is equilateral.

Solutionbank C2

Edexcel Modular Mathematics for AS and A-Level

Coordinate geometry in the (x,y) plane

Exercise F, Question 19

Question:

The points $P(2, 2)$, $Q(2 + \sqrt{3}, 5)$ and $R(2 - \sqrt{3}, 5)$ lie on the circle $(x - 2)^2 + (y - 4)^2 = r^2$.

(a) Find the value of r .

(b) Show that $\triangle PQR$ is equilateral.

Solution:

(a) Substitute $(2, 2)$ into $(x - 2)^2 + (y - 4)^2 = r^2$

$$(2 - 2)^2 + (2 - 4)^2 = r^2$$

$$0^2 + (-2)^2 = r^2$$

$$r^2 = 4$$

$$r = 2$$

(b) (1) The distance between $(2, 2)$ and $(2 + \sqrt{3}, 5)$ is

$$\begin{aligned} & \sqrt{(x_2 - x_1)^2 + (y_2 - y_1)^2} \\ &= \sqrt{(2 + \sqrt{3} - 2)^2 + (5 - 2)^2} \\ &= \sqrt{(\sqrt{3})^2 + 3^2} \\ &= \sqrt{3 + 9} \\ &= \sqrt{12} \end{aligned}$$

(2) The distance between $(2, 2)$ and $(2 - \sqrt{3}, 5)$ is

$$\begin{aligned} & \sqrt{(x_2 - x_1)^2 + (y_2 - y_1)^2} \\ &= \sqrt{(2 - \sqrt{3} - 2)^2 + (5 - 2)^2} \\ &= \sqrt{(-\sqrt{3})^2 + (3)^2} \\ &= \sqrt{3 + 9} \\ &= \sqrt{12} \end{aligned}$$

(3) The distance between $(2 + \sqrt{3}, 5)$ and $(2 - \sqrt{3}, 5)$ is

$$\begin{aligned} & \sqrt{(x_2 - x_1)^2 + (y_2 - y_1)^2} \\ &= \sqrt{[(2 - \sqrt{3}) - (2 + \sqrt{3})]^2 + (5 - 5)^2} \\ &= \sqrt{(2 - \sqrt{3} - 2 - \sqrt{3})^2 + 0^2} \\ &= \sqrt{(-2\sqrt{3})^2} \\ &= \sqrt{(-2)^2 \times (\sqrt{3})^2} \\ &= \sqrt{4 \times 3} \\ &= \sqrt{12} \end{aligned}$$

So PQ , QR and PR all equal $\sqrt{12}$.

$\triangle PQR$ is equilateral.

Solutionbank C2

Edexcel Modular Mathematics for AS and A-Level

Coordinate geometry in the (x,y) plane

Exercise F, Question 20

Question:

The points $A(-3, -2)$, $B(-6, 0)$ and $C(p, q)$ lie on a circle centre $\left(-\frac{5}{2}, 2\right)$. The line BC is a diameter of the circle.

- (a) Find the value of p and q .
- (b) Find the gradient of (i) AB (ii) AC .
- (c) Show that AB is perpendicular to AC .

Solution:

(a) The mid-point of $(-6, 0)$ and (p, q) is $\left(-\frac{5}{2}, 2\right)$.

$$\text{So } \left(\frac{-6+p}{2}, \frac{0+q}{2}\right) = \left(-\frac{5}{2}, 2\right)$$

$$\frac{-6+p}{2} = -\frac{5}{2}$$

$$-6+p = -5$$

$$p = -5 + 6$$

$$p = 1$$

$$\frac{0+q}{2} = 2$$

$$\frac{q}{2} = 2$$

$$q = 4$$

(b) (i) The gradient of the line joining $(-3, -2)$ and $(-6, 0)$ is

$$\frac{y_2 - y_1}{x_2 - x_1} = \frac{0 - (-2)}{-6 - (-3)} = \frac{2}{-6+3} = \frac{2}{-3} = -\frac{2}{3}$$

(ii) The gradient of the line joining $(-3, -2)$ and $(1, 4)$ is

$$\frac{y_2 - y_1}{x_2 - x_1} = \frac{4 - (-2)}{1 - (-3)} = \frac{4+2}{1+3} = \frac{6}{4} = \frac{3}{2}$$

(c) Two lines are perpendicular if $m_1 \times m_2 = -1$.

$$\text{Now } -\frac{2}{3} \times \frac{3}{2} = -1 \quad \checkmark$$

So AB is perpendicular to AC .

Solutionbank C2

Edexcel Modular Mathematics for AS and A-Level

The binomial expansion

Exercise A, Question 1

Question:

Write down the expansion of:

(a) $(x + y)^4$

(b) $(p + q)^5$

(c) $(a - b)^3$

(d) $(x + 4)^3$

(e) $(2x - 3)^4$

(f) $(a + 2)^5$

(g) $(3x - 4)^4$

(h) $(2x - 3y)^4$

Solution:

(a) $(x + y)^4$ would have coefficients and terms

$$\begin{array}{ccccccc} 1 & 4 & 6 & 4 & 1 & & \\ x^4 & x^3y & x^2y^2 & xy^3 & y^4 & & \end{array}$$

$$(x + y)^4 = 1x^4 + 4x^3y + 6x^2y^2 + 4xy^3 + 1y^4$$

(b) $(p + q)^5$ would have coefficients and terms

$$\begin{array}{ccccccc} 1 & 5 & 10 & 10 & 5 & 1 & \\ p^5 & p^4q & p^3q^2 & p^2q^3 & pq^4 & q^5 & \end{array}$$

$$(p + q)^5 = 1p^5 + 5p^4q + 10p^3q^2 + 10p^2q^3 + 5pq^4 + 1q^5$$

(c) $(a - b)^3$ would have coefficients and terms

$$\begin{array}{ccccccc} 1 & 3 & & 3 & & 1 & \\ a^3 & a^2(-b) & & a(-b)^2 & & (-b)^3 & \end{array}$$

$$(a - b)^3 = 1a^3 - 3a^2b + 3ab^2 - 1b^3$$

(d) $(x + 4)^3$ would have coefficients and terms

$$\begin{array}{cccc} 1 & 3 & 3 & 1 \\ x^3 & x^2 4 & x 4^2 & 4^3 \end{array}$$

$$(x + 4)^3 = 1x^3 + 12x^2 + 48x + 64$$

(e) $(2x - 3)^4$ would have coefficients and terms

$$\begin{array}{ccccccc} 1 & & 4 & & 6 & & 4 & & 1 \\ (2x)^4 & (2x)^3 & (-3) & (2x)^2 & (-3)^2 & (2x) & (-3)^3 & (-3)^4 \end{array}$$

$$\begin{aligned} (2x - 3)^4 &= 1(2x)^4 + 4(2x)^3(-3) + 6(2x)^2(-3)^2 + 4(2x)(-3)^3 + 1(-3)^4 \\ (2x - 3)^4 &= 16x^4 - 96x^3 + 216x^2 - 216x + 81 \end{aligned}$$

(f) $(a + 2)^5$ would have coefficients and terms

$$\begin{array}{ccccccc} 1 & 5 & 10 & 10 & 5 & 1 \\ a^5 & a^4 2 & a^3 2^2 & a^2 2^3 & a 2^4 & 2^5 \end{array}$$

$$(a + 2)^5 = 1a^5 + 10a^4 + 40a^3 + 80a^2 + 80a + 32$$

(g) $(3x - 4)^4$ would have coefficients and terms

$$\begin{array}{ccccccc} 1 & & 4 & & 6 & & 4 & & 1 \\ (3x)^4 & (3x)^3 & (-4) & (3x)^2 & (-4)^2 & (3x) & (-4)^3 & (-4)^4 \end{array}$$

$$\begin{aligned} (3x - 4)^4 &= 1(3x)^4 + 4(3x)^3(-4) + 6(3x)^2(-4)^2 + 4(3x)(-4)^3 + 1(-4)^4 \\ (3x - 4)^4 &= 81x^4 - 432x^3 + 864x^2 - 768x + 256 \end{aligned}$$

(h) $(2x - 3y)^4$ would have coefficients and terms

$$\begin{array}{ccccccc} 1 & & 4 & & 6 & & 4 & & 1 \\ (2x)^4 & (2x)^3 & (-3y) & (2x)^2 & (-3y)^2 & (2x) & (-3y)^3 & (-3y)^4 \end{array}$$

$$\begin{aligned} (2x - 3y)^4 &= 1(2x)^4 + 4(2x)^3(-3y) + 6(2x)^2(-3y)^2 + 4(2x)(-3y)^3 + 1(-3y)^4 \\ (2x - 3y)^4 &= 16x^4 - 96x^3y + 216x^2y^2 - 216xy^3 + 81y^4 \end{aligned}$$

Solutionbank C2

Edexcel Modular Mathematics for AS and A-Level

The binomial expansion

Exercise A, Question 2

Question:

Find the coefficient of x^3 in the expansion of:

(a) $(4 + x)^4$

(b) $(1 - x)^5$

(c) $(3 + 2x)^3$

(d) $(4 + 2x)^5$

(e) $(2 + x)^6$

(f) $\left(4 - \frac{1}{2}x\right)^4$

(g) $(x + 2)^5$

(h) $(3 - 2x)^4$

Solution:

(a) $(4 + x)^4$ would have coefficients 1 4 6 ④ 1
 The circled number is the coefficient of the term 4^1x^3 .
 Term is $4 \times 4^1x^3 = 16x^3$
 Coefficient = 16

(b) $(1 - x)^5$ would have coefficients 1 5 10 ⑩ 5 1
 The circled number is the coefficient of the term $1^2(-x)^3$.
 Term is $10 \times 1^2(-x)^3 = -10x^3$
 Coefficient = -10

(c) $(3 + 2x)^3$ would have coefficients 1 3 3 ①
 The circled number is the coefficient of the term $(2x)^3$.
 Term is $1 \times (2x)^3 = 8x^3$
 Coefficient = 8

(d) $(4 + 2x)^5$ would have coefficients 1 5 10 ⑩ 5 1
 The circled number is the coefficient of the term $4^2(2x)^3$.
 Term is $10 \times 4^2(2x)^3 = 1280x^3$
 Coefficient = 1280

(e) $(2 + x)^6$ would have coefficients 1 6 15 ⑳ 15 6 1
 The circled number is the coefficient of the term 2^3x^3 .
 Term is $20 \times 2^3x^3 = 160x^3$
 Coefficient = 160

(f) $\left(4 - \frac{1}{2}x\right)^4$ would have coefficients 1 4 6 ④ 1

The circled number is the coefficients of the term $4 \left(-\frac{1}{2}x\right)^3$.

Term is $4 \times 4 \left(-\frac{1}{2}x\right)^3 = -2x^3$

Coefficient = -2

(g) $(x + 2)^5$ would have coefficients 1 5 ⑩ 10 5 1

The circled number is the coefficient of the term $x^3 2^2$.

Term is $10 \times x^3 2^2 = 40x^3$

Coefficient = 40

(h) $(3 - 2x)^4$ would have coefficients 1 4 6 ④ 1

The circled number is the coefficient of the term $3^1 (-2x)^3$.

Term is $4 \times 3^1 (-2x)^3 = -96x^3$

Coefficient = -96

Solutionbank C2

Edexcel Modular Mathematics for AS and A-Level

The binomial expansion

Exercise A, Question 3

Question:

Fully expand the expression $(1 + 3x)(1 + 2x)^3$.

Solution:

$(1 + 2x)^3$ has coefficients and terms

$$\begin{matrix} 1 & 3 & 3 & 1 \\ 1^3 & 1^2(2x) & 1(2x)^2 & (2x)^3 \end{matrix}$$

Hence $(1 + 2x)^3 = 1 + 6x + 12x^2 + 8x^3$

$$\begin{aligned} & (1 + 3x)(1 + 2x)^3 \\ &= (1 + 3x)(1 + 6x + 12x^2 + 8x^3) \\ &= 1(1 + 6x + 12x^2 + 8x^3) + 3x(1 + 6x + 12x^2 + 8x^3) \\ &= 1 + 6x + 12x^2 + 8x^3 + 3x + 18x^2 + 36x^3 + 24x^4 \\ &= 1 + 9x + 30x^2 + 44x^3 + 24x^4 \end{aligned}$$

© Pearson Education Ltd 2008

Solutionbank C2

Edexcel Modular Mathematics for AS and A-Level

The binomial expansion

Exercise A, Question 4

Question:

Expand $(2 + y)^3$. Hence or otherwise, write down the expansion of $(2 + x - x^2)^3$ in ascending powers of x .

Solution:

$(2 + y)^3$ has coefficients and terms

$$\begin{array}{cccc} 1 & 3 & 3 & 1 \\ 2^3 & 2^2y & 2y^2 & y^3 \end{array}$$

Therefore, $(2 + y)^3 = 8 + 12y + 6y^2 + 1y^3$

Substitute $y = x - x^2$

$$\Rightarrow (2 + x - x^2)^3 = 8 + 12(x - x^2) + 6(x - x^2)^2 + 1(x - x^2)^3$$

$$\Rightarrow (2 + x - x^2)^3 = 8 + 12x(1 - x) + 6x^2(1 - x)^2 + x^3(1 - x)^3$$

Now

$$(1 - x)^2 = (1 - x)(1 - x) = 1 - 2x + x^2$$

and

$$(1 - x)^3 = (1 - x)(1 - x)^2$$

$$(1 - x)^3 = (1 - x)(1 - 2x + x^2)$$

$$(1 - x)^3 = 1 - 2x + x^2 - x + 2x^2 - x^3$$

$$(1 - x)^3 = 1 - 3x + 3x^2 - x^3$$

Or, using Pascal's Triangles

$$(1 - x)^3 = 1(1)^3 + 3(1)^2(-x) + 3(1)(-x)^2 + 1(-x)^3$$

$$(1 - x)^3 = 1 - 3x + 3x^2 - x^3$$

So $(2 + x - x^2)^3 = 8 + 12x(1 - x) + 6x^2(1 - 2x + x^2) + x^3(1 - 3x + 3x^2 - x^3)$

$$\Rightarrow (2 + x - x^2)^3 = 8 + 12x - 12x^2 + 6x^2 - 12x^3 + 6x^4 + x^3 - 3x^4 + 3x^5 - x^6$$

$$\Rightarrow (2 + x - x^2)^3 = 8 + 12x - 6x^2 - 11x^3 + 3x^4 + 3x^5 - x^6$$

Solutionbank C2

Edexcel Modular Mathematics for AS and A-Level

The binomial expansion

Exercise A, Question 5

Question:

Find the coefficient of the term in x^3 in the expansion of $(2 + 3x)^3(5 - x)^3$.

Solution:

$(2 + 3x)^3$ would have coefficients and terms

$$\begin{array}{cccc} 1 & 3 & 3 & 1 \\ 2^3 & 2^2 & (3x) & 2(3x)^2 & (3x)^3 \\ (2 + 3x)^3 = 1 \times 2^3 + 3 \times 2^2(3x) + 3 \times 2(3x)^2 + 1 \times (3x)^3 \\ (2 + 3x)^3 = 8 + 36x + 54x^2 + 27x^3 \end{array}$$

$(5 - x)^3$ would have coefficients and terms

$$\begin{array}{cccc} 1 & 3 & 3 & 1 \\ 5^3 & 5^2 & (-x) & 5(-x)^2 & (-x)^3 \\ (5 - x)^3 = 1 \times 5^3 + 3 \times 5^2(-x) + 3 \times 5(-x)^2 + 1 \times (-x)^3 \\ (5 - x)^3 = 125 - 75x + 15x^2 - x^3 \end{array}$$

$$(2 + 3x)^3(5 - x)^3 = \underbrace{(8 + 36x + 54x^2 + 27x^3)(125 - 75x + 15x^2 - x^3)}$$

Term in x^3 is

$$\begin{aligned} 8 \times (-x^3) + 36x \times 15x^2 + 54x^2 \times (-75x) + 27x^3 \times 125 \\ = -8x^3 + 540x^3 - 4050x^3 + 3375x^3 \\ = -143x^3 \end{aligned}$$

Coefficient of $x^3 = -143$

Solutionbank C2

Edexcel Modular Mathematics for AS and A-Level

The binomial expansion

Exercise A, Question 6

Question:

The coefficient of x^2 in the expansion of $(2 + ax)^3$ is 54. Find the possible values of the constant a .

Solution:

$(2 + ax)^3$ has coefficients 1 3 ③ 1

The circled number is the coefficient of the term $2^1 (ax)^2$.

Term in x^2 is $3 \times 2^1 \times (ax)^2 = 6a^2x^2$

Coefficient of x^2 is $6a^2$.

Hence

$$6a^2 = 54 \quad (\div 6)$$

$$a^2 = 9$$

$$a = \pm 3$$

© Pearson Education Ltd 2008

Solutionbank C2

Edexcel Modular Mathematics for AS and A-Level

The binomial expansion

Exercise A, Question 7

Question:

The coefficient of x^2 in the expansion of $(2 - x)(3 + bx)^3$ is 45. Find possible values of the constant b .

Solution:

$(3 + bx)^3$ has coefficients and terms

$$1 \quad 3 \quad 3 \quad 1$$

$$3^3 \quad 3^2 (bx) \quad 3 (bx)^2 \quad (bx)^3$$

$$(3 + bx)^3 = 1 \times 3^3 + 3 \times 3^2 bx + 3 \times 3 (bx)^2 + 1 \times (bx)^3$$

$$(3 + bx)^3 = 27 + 27bx + 9b^2x^2 + b^3x^3$$

So $(2 - x)(3 + bx)^3 = (2 - x)(27 + 27bx + 9b^2x^2 + b^3x^3)$

Term in x^2 is $2 \times 9b^2x^2 - x \times 27bx = 18b^2x^2 - 27bx^2$

Coefficient of x^2 is $18b^2 - 27b$

Hence

$$18b^2 - 27b = 45 \quad (\div 9)$$

$$2b^2 - 3b = 5$$

$$2b^2 - 3b - 5 = 0$$

$$(2b - 5)(b + 1) = 0$$

$$b = \frac{5}{2}, -1$$

Solutionbank C2

Edexcel Modular Mathematics for AS and A-Level

The binomial expansion

Exercise A, Question 8

Question:

Find the term independent of x in the expansion of $\left(x^2 - \frac{1}{2x}\right)^3$.

Solution:

$\left(x^2 - \frac{1}{2x}\right)^3$ has coefficients and terms

$$\begin{array}{cccc} 1 & 3 & 3 & 1 \\ (x^2)^3 & (x^2)^2(-\frac{1}{2x})^1 & (x^2)(-\frac{1}{2x})^2 & (-\frac{1}{2x})^3 \\ & & \uparrow & \end{array}$$

This term would be independent of x as the x 's cancel.

$$\text{Term independent of } x \text{ is } 3 \binom{3}{2} \binom{3}{1} \left(x^2\right)^2 \left(-\frac{1}{2x}\right)^1 = 3 \cdot 3 \times \frac{1}{4x^2} = \frac{3}{4}$$

Solutionbank C2

Edexcel Modular Mathematics for AS and A-Level

The binomial expansion

Exercise B, Question 1

Question:

Find the values of the following:

(a) $4!$

(b) $6!$

(c) $\frac{8!}{6!}$

(d) $\frac{10!}{9!}$

(e) 4C_2

(f) 8C_6

(g) 5C_2

(h) 6C_3

(i) ${}^{10}C_9$

(j) 6C_2

(k) 8C_5

(l) nC_3

Solution:

(a) $4! = 4 \times 3 \times 2 \times 1 = 24$

(b) $6! = 6 \times 5 \times 4 \times 3 \times 2 \times 1 = 720$

(c) $\frac{8!}{6!} = \frac{8 \times 7 \times 6 \times 5 \times 4 \times 3 \times 2 \times 1}{6 \times 5 \times 4 \times 3 \times 2 \times 1} = 8 \times 7 = 56$

(d) $\frac{10!}{9!} = \frac{10 \times 9!}{9!} = 10$

(e) ${}^4C_2 = \frac{4!}{(4-2)!2!} = \frac{4!}{2!2!} = \frac{4 \times 3 \times 2 \times 1}{2 \times 1 \times 2 \times 1} = \frac{12}{2} = 6$

$$(f) {}^8C_6 = \frac{8!}{(8-6)!6!} = \frac{8!}{2!6!} = \frac{8 \times 7 \times 6!}{2!6!} = \frac{56}{2} = 28$$

$$(g) {}^5C_2 = \frac{5!}{(5-2)!2!} = \frac{5!}{3!2!} = \frac{5 \times 4 \times 3!}{3!2!} = \frac{20}{2} = 10$$

$$(h) {}^6C_3 = \frac{6!}{(6-3)!3!} = \frac{6!}{3!3!} = \frac{6 \times 5 \times 4 \times 3!}{3! \times 3!} = \frac{6 \times 5 \times 4}{6} = 20$$

$$(i) {}^{10}C_9 = \frac{10!}{(10-9)!9!} = \frac{10!}{1!9!} = \frac{10 \times 9!}{1!9!} = \frac{10}{1} = 10$$

$$(j) {}^6C_2 = \frac{6!}{(6-2)!2!} = \frac{6!}{4!2!} = \frac{6 \times 5 \times 4!}{4!2!} = \frac{30}{2} = 15$$

$$(k) {}^8C_5 = \frac{8!}{(8-5)!5!} = \frac{8 \times 7 \times 6 \times 5!}{3!5!} = \frac{8 \times 7 \times 6}{6} = 56$$

$$(l) {}^nC_3 = \frac{n!}{(n-3)!3!} = \frac{n \times (n-1) \times (n-2) \times (n-3)!}{(n-3)!3!} = \frac{n(n-1)(n-2)}{6}$$

© Pearson Education Ltd 2008

Solutionbank C2

Edexcel Modular Mathematics for AS and A-Level

The binomial expansion

Exercise B, Question 2

Question:

Calculate:

(a) 4C_0

(b) $\binom{4}{1}$

(c) 4C_2

(d) $\binom{4}{3}$

(e) $\binom{4}{4}$

Now look at line 4 of Pascal's Triangle. Can you find any connection?

Solution:

$$(a) {}^4C_0 = \frac{4!}{(4-0)!0!} = \frac{4!}{4!0!} = 1$$

$$(b) \binom{4}{1} = \frac{4!}{(4-1)!1!} = \frac{4!}{3!1!} = \frac{4 \times 3!}{3!1!} = 4$$

$$(c) {}^4C_2 = \frac{4!}{(4-2)!2!} = \frac{4!}{2!2!} = \frac{4 \times 3 \times 2!}{2!2!} = \frac{12}{2} = 6$$

$$(d) \binom{4}{3} = \frac{4!}{(4-3)!3!} = \frac{4!}{1!3!} = \frac{4 \times 3!}{1!3!} = \frac{4}{1} = 4$$

$$(e) \binom{4}{4} = \frac{4!}{(4-4)!4!} = \frac{4!}{0!4!} = \frac{1}{0!} = 1$$

The numbers 1, 4, 6, 4, 1 form the fourth line of Pascal's Triangle.

Solutionbank C2

Edexcel Modular Mathematics for AS and A-Level

The binomial expansion

Exercise B, Question 3

Question:

Write using combination notation:

- (a) Line 3 of Pascal's Triangle.
- (b) Line 5 of Pascal's Triangle.

Solution:

(a) Line 3 of Pascal's Triangle is

$$\binom{3}{0} \quad \binom{3}{1} \quad \binom{3}{2} \quad \binom{3}{3}$$

(b) Line 5 of Pascal's Triangle is

$$\binom{5}{0} \quad \binom{5}{1} \quad \binom{5}{2} \quad \binom{5}{3} \quad \binom{5}{4} \quad \binom{5}{5}$$

Solutionbank C2

Edexcel Modular Mathematics for AS and A-Level

The binomial expansion

Exercise B, Question 4

Question:

Why is 6C_2 equal to $\binom{6}{4}$?

- (a) Answer using ideas on choosing from a group.
 (b) Answer by calculating both quantities.

Solution:

(a) 6C_2 or $\binom{6}{2}$ is the number of ways of choosing 2 items from a group of 6 items.

$\binom{6}{4}$ or 6C_4 is the number of ways of choosing 4 items from a group of 6 items.

These have to be the same.

For example, if you have a group of six people and want to pick a team of four, you have automatically selected a team of two.

$$(b) {}^6C_2 = \frac{6!}{(6-2)!2!} = \frac{6!}{4!2!} = \frac{6 \times 5 \times 4!}{4! 2!} = 15$$

$$\binom{6}{4} = \frac{6!}{(6-4)!4!} = \frac{6!}{2!4!} = \frac{6 \times 5 \times 4!}{2! 4!} = 15$$

$$\text{Hence } {}^6C_2 = \binom{6}{4}$$

Solutionbank C2

Edexcel Modular Mathematics for AS and A-Level

The binomial expansion

Exercise C, Question 1

Question:

Write down the expansion of the following:

(a) $(2x + y)^4$

(b) $(p - q)^5$

(c) $(1 + 2x)^4$

(d) $(3 + x)^4$

(e) $\left(1 - \frac{1}{2}x\right)^4$

(f) $(4 - x)^4$

(g) $(2x + 3y)^5$

(h) $(x + 2)^6$

Solution:

(a) $(2x + y)^4$
 $= {}^4C_0 (2x)^4 + {}^4C_1 (2x)^3 (y) + {}^4C_2 (2x)^2 (y)^2 + {}^4C_3 (2x)^1 (y)^3 + {}^4C_4 (y)^4$
 $= 1 \times 16x^4 + 4 \times 8x^3y + 6 \times 4x^2y^2 + 4 \times 2xy^3 + 1 \times y^4$
 $= 16x^4 + 32x^3y + 24x^2y^2 + 8xy^3 + y^4$

(b) $(p - q)^5$
 $= {}^5C_0 p^5 + {}^5C_1 p^4 (-q) + {}^5C_2 p^3 (-q)^2 + {}^5C_3 p^2 (-q)^3 + {}^5C_4 p (-q)^4 + {}^5C_5 (-q)^5$
 $= 1 \times p^5 + 5 \times (-p^4q) + 10 \times p^3q^2 + 10 \times (-p^2q^3) + 5 \times pq^4 + 1 \times (-q^5)$
 $= p^5 - 5p^4q + 10p^3q^2 - 10p^2q^3 + 5pq^4 - q^5$

(c) $(1 + 2x)^4$
 $= {}^4C_0 (1)^4 + {}^4C_1 (1)^3 (2x)^1 + {}^4C_2 (1)^2 (2x)^2 + {}^4C_3 (1) (2x)^3 + {}^4C_4 (2x)^4$
 $= 1 \times 1 + 4 \times 2x + 6 \times 4x^2 + 4 \times 8x^3 + 1 \times 16x^4$
 $= 1 + 8x + 24x^2 + 32x^3 + 16x^4$

(d) $(3 + x)^4$
 $= {}^4C_0 (3)^4 + {}^4C_1 (3)^3 (x) + {}^4C_2 (3)^2 (x)^2 + {}^4C_3 (3) (x)^3 + {}^4C_4 (x)^4$
 $= 1 \times 81 + 4 \times 27x + 6 \times 9x^2 + 4 \times 3x^3 + 1 \times x^4$
 $= 81 + 108x + 54x^2 + 12x^3 + x^4$

(e) $\left(1 - \frac{1}{2}x\right)^4$

$$\begin{aligned}
&= {}^4C_0(1)^4 + {}^4C_1(1)^3 \left(-\frac{1}{2}x\right) + {}^4C_2(1)^2 \left(-\frac{1}{2}x\right)^2 + {}^4C_3 \binom{1}{1} \left(-\frac{1}{2}x\right)^3 + {}^4C_4 \left(-x\right)^4 \\
&= 1 \times 1 + 4 \times \left(-\frac{1}{2}x\right) + 6 \times \frac{1}{4}x^2 + 4 \times \left(-\frac{1}{8}x^3\right) + 1 \times \frac{1}{16}x^4 \\
&= 1 - 2x + \frac{3}{2}x^2 - \frac{1}{2}x^3 + \frac{1}{16}x^4
\end{aligned}$$

$$\begin{aligned}
\text{(f)} \quad &(4-x)^4 \\
&= {}^4C_0(4)^4 + {}^4C_1(4)^3(-x) + {}^4C_2(4)^2(-x)^2 + {}^4C_3(4)^1(-x)^3 + {}^4C_4(-x)^4 \\
&= 1 \times 256 + 4 \times (-64x) + 6 \times 16x^2 + 4 \times (-4x^3) + 1 \times x^4 \\
&= 256 - 256x + 96x^2 - 16x^3 + x^4
\end{aligned}$$

$$\begin{aligned}
\text{(g)} \quad &(2x+3y)^5 \\
&= {}^5C_0(2x)^5 + {}^5C_1(2x)^4(3y) + {}^5C_2(2x)^3(3y)^2 + {}^5C_3(2x)^2(3y)^3 + {}^5C_4(2x)(3y)^4 + {}^5C_5(3y)^5 \\
&= 1 \times 32x^5 + 5 \times 48x^4y + 10 \times 72x^3y^2 + 10 \times 108x^2y^3 + 5 \times 162xy^4 + 1 \times 243y^5 \\
&= 32x^5 + 240x^4y + 720x^3y^2 + 1080x^2y^3 + 810xy^4 + 243y^5
\end{aligned}$$

$$\begin{aligned}
\text{(h)} \quad &(x+2)^6 \\
&= {}^6C_0(x)^6 + {}^6C_1(x)^5 \cdot 2^1 + {}^6C_2(x)^4 \cdot 2^2 + {}^6C_3(x)^3 \cdot 2^3 + {}^6C_4(x)^2 \cdot 2^4 + {}^6C_5(x)^1 \cdot 2^5 + {}^6C_6 \cdot 2^6 \\
&= 1 \times x^6 + 6 \times 2x^5 + 15 \times 4x^4 + 20 \times 8x^3 + 15 \times 16x^2 + 6 \times 32x + 1 \times 64 \\
&= x^6 + 12x^5 + 60x^4 + 160x^3 + 240x^2 + 192x + 64
\end{aligned}$$

Solutionbank C2

Edexcel Modular Mathematics for AS and A-Level

The binomial expansion

Exercise C, Question 2

Question:

Find the term in x^3 of the following expansions:

(a) $(3 + x)^5$

(b) $(2x + y)^5$

(c) $(1 - x)^6$

(d) $(3 + 2x)^5$

(e) $(1 + x)^{10}$

(f) $(3 - 2x)^6$

(g) $(1 + x)^{20}$

(h) $(4 - 3x)^7$

Solution:

(a) $(3 + x)^5$

Term in x^3 is ${}^5C_3 (3)^2 (x)^3 = 10 \times 9x^3 = 90x^3$

(b) $(2x + y)^5$

Term in x^3 is ${}^5C_2 (2x)^3 (y)^2 = 10 \times 8x^3y^2 = 80x^3y^2$

(c) $(1 - x)^6$

Term in x^3 is ${}^6C_3 (1)^3 (-x)^3 = 20 \times (-1x^3) = -20x^3$

(d) $(3 + 2x)^5$

Term in x^3 is ${}^5C_3 (3)^2 (2x)^3 = 10 \times 72x^3 = 720x^3$

(e) $(1 + x)^{10}$

Term in x^3 is ${}^{10}C_3 (1)^7 (x)^3 = 120 \times 1x^3 = 120x^3$

(f) $(3 - 2x)^6$

Term in x^3 is ${}^6C_3 (3)^3 (-2x)^3 = 20 \times (-216x^3) = -4320x^3$

(g) $(1 + x)^{20}$

Term in x^3 is ${}^{20}C_3 (1)^{17} (x)^3 = 1140 \times 1x^3 = 1140x^3$

(h) $(4 - 3x)^7$

Term in x^3 is ${}^7C_3 (4)^4 (-3x)^3 = 35 \times (-6912x^3) = -241\,920x^3$

Solutionbank C2

Edexcel Modular Mathematics for AS and A-Level

The binomial expansion

Exercise C, Question 3

Question:

Use the binomial theorem to find the first four terms in the expansion of:

(a) $(1 + x)^{10}$

(b) $(1 - 2x)^5$

(c) $(1 + 3x)^6$

(d) $(2 - x)^8$

(e) $\left(2 - \frac{1}{2}x\right)^{10}$

(f) $(3 - x)^7$

(g) $(x + 2y)^8$

(h) $(2x - 3y)^9$

Solution:

(a) $(1 + x)^{10}$
 $= {}^{10}C_0 1^{10} + {}^{10}C_1 1^9 x^1 + {}^{10}C_2 1^8 x^2 + {}^{10}C_3 1^7 x^3 + \dots$
 $= 1 + 10 \times 1x + 45 \times 1x^2 + 120 \times 1x^3 + \dots$
 $= 1 + 10x + 45x^2 + 120x^3 + \dots$

(b) $(1 - 2x)^5$
 $= {}^5C_0 1^5 + {}^5C_1 1^4 (-2x)^1 + {}^5C_2 1^3 (-2x)^2 + {}^5C_3 1^2 (-2x)^3 + \dots$
 $= 1 \times 1 + 5 \times (-2x) + 10 \times 4x^2 + 10 \times (-8x^3) + \dots$
 $= 1 - 10x + 40x^2 - 80x^3 + \dots$

(c) $(1 + 3x)^6$
 $= {}^6C_0 1^6 + {}^6C_1 1^5 (3x)^1 + {}^6C_2 1^4 (3x)^2 + {}^6C_3 1^3 (3x)^3 + \dots$
 $= 1 \times 1 + 6 \times 3x + 15 \times 9x^2 + 20 \times 27x^3 + \dots$
 $= 1 + 18x + 135x^2 + 540x^3 + \dots$

(d) $(2 - x)^8$
 $= {}^8C_0 2^8 + {}^8C_1 2^7 (-x)^1 + {}^8C_2 2^6 (-x)^2 + {}^8C_3 2^5 (-x)^3 + \dots$
 $= 1 \times 256 + 8 \times (-128x) + 28 \times 64x^2 + 56 \times (-32x^3) + \dots$
 $= 256 - 1024x + 1792x^2 - 1792x^3 + \dots$

(e) $\left(2 - \frac{1}{2}x\right)^{10}$

$$\begin{aligned}
&= {}^{10}C_0 2^{10} + {}^{10}C_1 2^9 \left(-\frac{1}{2}x \right)^1 + {}^{10}C_2 2^8 \left(-\frac{1}{2}x \right)^2 + {}^{10}C_3 2^7 \left(-\frac{1}{2}x \right)^3 + \dots \\
&= 1 \times 1024 + 10 \times (-256x) + 45 \times 64x^2 + 120 \times (-16x^3) + \dots \\
&= 1024 - 2560x + 2880x^2 - 1920x^3 + \dots
\end{aligned}$$

$$\begin{aligned}
\text{(f)} \quad &(3-x)^7 \\
&= {}^7C_0 3^7 + {}^7C_1 3^6 (-x)^1 + {}^7C_2 3^5 (-x)^2 + {}^7C_3 3^4 (-x)^3 + \dots \\
&= 1 \times 2187 + 7 \times (-729x) + 21 \times 243x^2 + 35 \times (-81x^3) + \dots \\
&= 2187 - 5103x + 5103x^2 - 2835x^3 + \dots
\end{aligned}$$

$$\begin{aligned}
\text{(g)} \quad &(x+2y)^8 \\
&= {}^8C_0 x^8 + {}^8C_1 x^7 (2y)^1 + {}^8C_2 x^6 (2y)^2 + {}^8C_3 x^5 (2y)^3 + \dots \\
&= 1 \times x^8 + 8 \times 2x^7y + 28 \times 4x^6y^2 + 56 \times 8x^5y^3 + \dots \\
&= x^8 + 16x^7y + 112x^6y^2 + 448x^5y^3 + \dots
\end{aligned}$$

$$\begin{aligned}
\text{(h)} \quad &(2x-3y)^9 \\
&= {}^9C_0 (2x)^9 + {}^9C_1 (2x)^8 (-3y)^1 + {}^9C_2 (2x)^7 (-3y)^2 + {}^9C_3 (2x)^6 (-3y)^3 + \dots \\
&= 1 \times 512x^9 + 9 \times (-768x^8y) + 36 \times 1152x^7y^2 + 84 \times (-1728x^6y^3) + \dots \\
&= 512x^9 - 6912x^8y + 41472x^7y^2 - 145152x^6y^3 + \dots
\end{aligned}$$

© Pearson Education Ltd 2008

Solutionbank C2

Edexcel Modular Mathematics for AS and A-Level

The binomial expansion

Exercise C, Question 4

Question:

The coefficient of x^2 in the expansion of $(2 + ax)^6$ is 60.
Find possible values of the constant a .

Solution:

$(2 + ax)^6$
Term in x^2 is ${}^6C_2 2^4 (ax)^2 = 15 \times 16a^2x^2 = 240a^2x^2$

Coefficient of x^2 is $240a^2$.

If this is equal to 60 then

$$240a^2 = 60 \quad (\div 240)$$

$$a^2 = \frac{1}{4} \quad \left(\sqrt{\quad} \right)$$

$$a = \pm \frac{1}{2}$$

Therefore $a = \pm \frac{1}{2}$.

Solutionbank C2

Edexcel Modular Mathematics for AS and A-Level

The binomial expansion

Exercise C, Question 5

Question:

The coefficient of x^3 in the expansion of $(3 + bx)^5$ is -720 .
Find the value of the constant b .

Solution:

$(3 + bx)^5$
Term in x^3 is ${}^5C_3 3^2 (bx)^3 = 10 \times 9b^3x^3 = 90b^3x^3$

Coefficient of x^3 is $90b^3$.

If this is equal to -720 then

$$90b^3 = -720 \quad (\div 90)$$

$$b^3 = -8 \quad (\sqrt{\quad})$$

$$b = -2$$

Hence $b = -2$.

© Pearson Education Ltd 2008

Solutionbank C2

Edexcel Modular Mathematics for AS and A-Level

The binomial expansion

Exercise C, Question 6

Question:

The coefficient of x^3 in the expansion of $(2+x)(3-ax)^4$ is 30.
Find the values of the constant a .

Solution:

$$\begin{aligned} & (3-ax)^4 \\ &= {}^4C_0 3^4 + {}^4C_1 3^3(-ax) + {}^4C_2 3^2(-ax)^2 + {}^4C_3 3^1(-ax)^3 + {}^4C_4(-ax)^4 \\ &= 1 \times 81 + 4 \times (-27ax) + 6 \times 9a^2x^2 + 4 \times (-3a^3x^3) + 1 \times a^4x^4 \\ &= 81 - 108ax + 54a^2x^2 - 12a^3x^3 + a^4x^4 \end{aligned}$$

$$(2+x)(3-ax)^4 =$$

$$(2+x)(81-108ax + 54a^2x^2 - 12a^3x^3 + a^4x^4)$$

Term in x^3 is $2 \times (-12a^3x^3) + x \times 54a^2x^2 = -24a^3x^3 + 54a^2x^3$

Hence

$$-24a^3 + 54a^2 = 30 \quad (\div 6)$$

$$-4a^3 + 9a^2 = 5$$

$$0 = 4a^3 - 9a^2 + 5 \quad (4 \times 1^3 - 9 \times 1^2 + 5 = 0 \Rightarrow a = 1 \text{ is a root})$$

$$0 = (a-1)(4a^2 - 5a - 5)$$

So $a = 1$ and

$$4a^2 - 5a - 5 = 0$$

Using the formula for roots,

$$a = \frac{5 \pm \sqrt{25+80}}{8} = \frac{5 \pm \sqrt{105}}{8}$$

Possible values of a are 1, $\frac{5 + \sqrt{105}}{8}$ and $\frac{5 - \sqrt{105}}{8}$

Solutionbank C2

Edexcel Modular Mathematics for AS and A-Level

The binomial expansion

Exercise C, Question 7

Question:

Write down the first four terms in the expansion of $\left(1 - \frac{x}{10}\right)^6$.

By substituting an appropriate value for x , find an approximate value to $(0.99)^6$. Use your calculator to find the degree of accuracy of your approximation.

Solution:

$$\begin{aligned} & \left(1 - \frac{x}{10}\right)^6 \\ &= {}^6C_0 1^6 + {}^6C_1 1^5 \left(-\frac{x}{10}\right) + {}^6C_2 1^4 \left(-\frac{x}{10}\right)^2 + {}^6C_3 1^3 \left(-\frac{x}{10}\right)^3 + \dots \\ &= 1 \times 1 + 6 \times \left(-\frac{x}{10}\right) + 15 \times \frac{x^2}{100} + 20 \times \left(-\frac{x^3}{1000}\right) + \dots \\ &= 1 - 0.6x + 0.15x^2 - 0.02x^3 + \dots \end{aligned}$$

We need to find $(0.99)^6$

$$\text{So } 1 - \frac{x}{10} = 0.99$$

$$\Rightarrow \frac{x}{10} = 0.01$$

$$\Rightarrow x = 0.1$$

Substitute $x = 0.1$ into our expansion for $\left(1 - \frac{x}{10}\right)^6$

$$\Rightarrow \left(1 - \frac{0.1}{10}\right)^6 = 1 - 0.6 \times 0.1 + 0.15 \times (0.1)^2 - 0.02 \times (0.1)^3 + \dots$$

$$\Rightarrow (0.99)^6 = 0.94148$$

From a calculator $(0.99)^6 = 0.941480149$

Accurate to 5 decimal places.

Solutionbank C2

Edexcel Modular Mathematics for AS and A-Level

The binomial expansion

Exercise C, Question 8

Question:

Write down the first four terms in the expansion of $\left(2 + \frac{x}{5}\right)^{10}$.

By substituting an appropriate value for x , find an approximate value to $(2.1)^{10}$. Use your calculator to find the degree of accuracy of your approximation.

Solution:

$$\begin{aligned} & \left(2 + \frac{x}{5}\right)^{10} \\ & {}^{10}C_0 2^{10} + {}^{10}C_1 2^9 \left(\frac{x}{5}\right)^1 + {}^{10}C_2 2^8 \left(\frac{x}{5}\right)^2 + {}^{10}C_3 2^7 \left(\frac{x}{5}\right)^3 + \dots \\ & = 1 \times 1024 + 10 \times \frac{512x}{5} + 45 \times \frac{256x^2}{25} + 120 \times \frac{128x^3}{125} + \dots \\ & = 1024 + 1024x + 460.8x^2 + 122.88x^3 + \dots \end{aligned}$$

If we want to find $(2.1)^{10}$ we need

$$2 + \frac{x}{5} = 2.1$$

$$\Rightarrow \frac{x}{5} = 0.1$$

$$\Rightarrow x = 0.5$$

Substitute $x = 0.5$ into the expansion for $\left(2 + \frac{x}{5}\right)^{10}$

$$(2.1)^{10} = 1024 + 1024 \times 0.5 + 460.8 \times (0.5)^2 + 122.88 \times (0.5)^3 + \dots$$

$$(2.1)^{10} = 1024 + 512 + 115.2 + 15.36 + \dots$$

$$(2.1)^{10} = 1666.56$$

From a calculator

$$(2.1)^{10} = 1667.988 \dots$$

Approximation is correct to 3 s.f. (both 1670).

Solutionbank C2

Edexcel Modular Mathematics for AS and A-Level

The binomial expansion

Exercise D, Question 1

Question:

Use the binomial expansion to find the first four terms of

(a) $(1 + x)^8$

(b) $(1 - 2x)^6$

(c) $\left(1 + \frac{x}{2}\right)^{10}$

(d) $(1 - 3x)^5$

(e) $(2 + x)^7$

(f) $(3 - 2x)^3$

(g) $(2 - 3x)^6$

(h) $(4 + x)^4$

(i) $(2 + 5x)^7$

Solution:

(a) Here $n = 8$ and $x = x$

$$(1 + x)^8 = 1 + 8x + \frac{8 \times 7}{2!}x^2 + \frac{8 \times 7 \times 6}{3!}x^3 + \dots$$

$$(1 + x)^8 = 1 + 8x + 28x^2 + 56x^3 + \dots$$

(b) Here $n = 6$ and $x = -2x$

$$(1 - 2x)^6 = 1 + 6 \binom{-2x}{1} + \frac{6 \times 5}{2!} (-2x)^2 + \frac{6 \times 5 \times 4}{3!} (-2x)^3 + \dots$$

$$(1 - 2x)^6 = 1 - 12x + 60x^2 - 160x^3 + \dots$$

(c) Here $n = 10$ and $x = \frac{x}{2}$

$$\left(1 + \frac{x}{2}\right)^{10} = 1 + 10 \binom{\frac{x}{2}}{1} + \frac{10 \times 9}{2!} \left(\frac{x}{2}\right)^2 + \frac{10 \times 9 \times 8}{3!} \left(\frac{x}{2}\right)^3 + \dots$$

$$\left(1 + \frac{x}{2}\right)^{10} = 1 + 5x + \frac{45}{4}x^2 + 15x^3 + \dots$$

(d) Here $n = 5$ and $x = -3x$

$$(1 - 3x)^5 = 1 + 5 \binom{-3x}{1} + \frac{5 \times 4}{2!} (-3x)^2 + \frac{5 \times 4 \times 3}{3!} (-3x)^3 + \dots$$

$$(1 - 3x)^5 = 1 - 15x + 90x^2 - 270x^3 + \dots$$

$$(e) (2 + x)^7 = \left[2 \left(1 + \frac{x}{2} \right) \right]^7 = 2^7 \left(1 + \frac{x}{2} \right)^7$$

Here $n = 7$ and $x = \frac{x}{2}$, so

$$(2 + x)^7 = 128 \left[1 + 7 \left(\frac{x}{2} \right) + \frac{7 \times 6}{2!} \left(\frac{x}{2} \right)^2 + \frac{7 \times 6 \times 5}{3!} \left(\frac{x}{2} \right)^3 + \dots \right]$$

$$(2 + x)^7 = 128 \left(1 + \frac{7}{2}x + \frac{21}{4}x^2 + \frac{35}{8}x^3 + \dots \right)$$

$$(2 + x)^7 = 128 + 448x + 672x^2 + 560x^3 + \dots$$

$$(f) (3 - 2x)^3 = \left[3 \left(1 - \frac{2x}{3} \right) \right]^3 = 3^3 \left(1 - \frac{2x}{3} \right)^3$$

Here $n = 3$ and $x = \frac{-2x}{3}$, so

$$(3 - 2x)^3 = 27 \left[1 + 3 \left(-\frac{2x}{3} \right) + \frac{3 \times 2}{2!} \left(-\frac{2x}{3} \right)^2 + \frac{3 \times 2 \times 1}{3!} \left(-\frac{2x}{3} \right)^3 \right]$$

$$(3 - 2x)^3 = 27 \left(1 - 2x + \frac{4}{3}x^2 - \frac{8}{27}x^3 \right)$$

$$(3 - 2x)^3 = 27 - 54x + 36x^2 - 8x^3$$

$$(g) (2 - 3x)^6 = \left[2 \left(1 - \frac{3x}{2} \right) \right]^6 = 2^6 \left(1 - \frac{3x}{2} \right)^6$$

Here $n = 6$ and $x = -\frac{3x}{2}$, so

$$(2 - 3x)^6 = 64 \left[1 + 6 \left(-\frac{3x}{2} \right) + \frac{6 \times 5}{2!} \left(-\frac{3x}{2} \right)^2 + \frac{6 \times 5 \times 4}{3!} \left(-\frac{3x}{2} \right)^3 + \dots \right]$$

$$(2 - 3x)^6 = 64 \left(1 - 9x + \frac{135}{4}x^2 - \frac{135}{2}x^3 + \dots \right)$$

$$(2 - 3x)^6 = 64 - 576x + 2160x^2 - 4320x^3 + \dots$$

$$(h) (4 + x)^4 = \left[4 \left(1 + \frac{x}{4} \right) \right]^4 = 4^4 \left(1 + \frac{x}{4} \right)^4$$

Here $n = 4$ and $x = \frac{x}{4}$, so

$$(4 + x)^4 = 256 \left[1 + 4 \left(\frac{x}{4} \right) + \frac{4 \times 3}{2!} \left(\frac{x}{4} \right)^2 + \frac{4 \times 3 \times 2}{3!} \left(\frac{x}{4} \right)^3 + \dots \right]$$

$$(4 + x)^4 = 256 \left(1 + x + \frac{3}{8}x^2 + \frac{1}{16}x^3 + \dots \right)$$

$$(4 + x)^4 = 256 + 256x + 96x^2 + 16x^3 + \dots$$

$$(i) (2 + 5x)^7 = \left[2 \left(1 + \frac{5x}{2} \right) \right]^7 = 2^7 \left(1 + \frac{5x}{2} \right)^7$$

Here $n = 7$ and $x = \frac{5x}{2}$, so

$$(2 + 5x)^7 = 128 \left[1 + 7 \left(\frac{5x}{2} \right) + \frac{7 \times 6}{2!} \left(\frac{5x}{2} \right)^2 + \frac{7 \times 6 \times 5}{3!} \left(\frac{5x}{2} \right)^3 + \dots \right]$$

$$(2 + 5x)^7 = 128 \left(1 + \frac{35}{2}x + \frac{525}{4}x^2 + \frac{4375}{8}x^3 + \dots \right)$$

$$(2 + 5x)^7 = 128 + 2240x + 16800x^2 + 70000x^3 + \dots$$

© Pearson Education Ltd 2008

Solutionbank C2

Edexcel Modular Mathematics for AS and A-Level

The binomial expansion

Exercise D, Question 2

Question:

If x is so small that terms of x^3 and higher can be ignored, show that:

$$(2 + x)(1 - 3x)^5 \approx 2 - 29x + 165x^2$$

Solution:

$$(1 - 3x)^5 = 1 + 5 \binom{5}{1} (-3x) + \frac{5 \times 4}{2!} (-3x)^2 + \dots$$

$$(1 - 3x)^5 = 1 - 15x + 90x^2 + \dots$$

$$\begin{aligned} (2 + x)(1 - 3x)^5 &= (2 + x)(1 - 15x + 90x^2 + \dots) \\ &= 2 - 30x + 180x^2 + \dots \\ &\quad + x - 15x^2 + \dots \\ &= 2 - 29x + 165x^2 \end{aligned}$$

© Pearson Education Ltd 2008

Solutionbank C2

Edexcel Modular Mathematics for AS and A-Level

The binomial expansion

Exercise D, Question 3

Question:

If x is so small that terms of x^3 and higher can be ignored, and
 $(2 - x)(3 + x)^4 \approx a + bx + cx^2$
 find the values of the constants a , b and c .

Solution:

$$\begin{aligned} & (3 + x)^4 \\ &= \left[3 \left(1 + \frac{x}{3} \right) \right]^4 \\ &= 3^4 \left(1 + \frac{x}{3} \right)^4 \\ &= 81 \left[1 + 4 \left(\frac{x}{3} \right) + \frac{4 \times 3}{2!} \left(\frac{x}{3} \right)^2 + \frac{4 \times 3 \times 2}{3!} \left(\frac{x}{3} \right)^3 + \dots \right] \\ &= 81 \left(1 + \frac{4}{3}x + \frac{2}{3}x^2 + \frac{4}{27}x^3 + \dots \right) \\ &= 81 + 108x + 54x^2 + 12x^3 + \dots \end{aligned}$$

$$\begin{aligned} & (2 - x)(3 + x)^4 \\ &= (2 - x)(81 + 108x + 54x^2 + 12x^3 + \dots) \\ &= 162 + 216x + 108x^2 + \dots \\ &\quad - 81x - 108x^2 + \dots \\ &= 162 + 135x + 0x^2 + \dots \end{aligned}$$

Therefore $a = 162$, $b = 135$, $c = 0$

Solutionbank C2

Edexcel Modular Mathematics for AS and A-Level

The binomial expansion

Exercise D, Question 4

Question:

When $(1 - 2x)^p$ is expanded, the coefficient of x^2 is 40. Given that $p > 0$, use this information to find:

- (a) The value of the constant p .
- (b) The coefficient of x .
- (c) The coefficient of x^3 .

Solution:

$$(1 - 2x)^p = 1 + p \binom{p}{1} (-2x) + \frac{p(p-1)}{2!} (-2x)^2 + \dots$$

$$= 1 - 2px + 2p(p-1)x^2 + \dots$$

$$\text{Coefficient of } x^2 \text{ is } 2p(p-1) = 40$$

$$\Rightarrow p(p-1) = 20$$

$$\Rightarrow p^2 - p - 20 = 0$$

$$\Rightarrow (p-5)(p+4) = 0$$

$$\Rightarrow p = 5$$

- (a) Value of p is 5.
- (b) Coefficient of x is $-2p = -10$.

$$(c) \text{ Term in } x^3 = \frac{p(p-1)(p-2)}{3!} (-2x)^3 = \frac{5 \times 4 \times 3}{3!} \binom{p}{3} (-8x^3) = -80x^3$$

$$\text{Coefficient of } x^3 \text{ is } -80.$$

Solutionbank C2

Edexcel Modular Mathematics for AS and A-Level

The binomial expansion

Exercise D, Question 5

Question:

Write down the first four terms in the expansion of $(1 + 2x)^8$. By substituting an appropriate value of x (which should be stated), find an approximate value of 1.02^8 . State the degree of accuracy of your answer.

Solution:

$$\begin{aligned}(1 + 2x)^8 &= 1 + 8 \times 2x + \frac{8 \times 7}{2!} (2x)^2 + \frac{8 \times 7 \times 6}{3!} (2x)^3 + \dots \\ &= 1 + 16x + 112x^2 + 448x^3 + \dots\end{aligned}$$

If we want an approximate value to $(1.02)^8$ we require

$$1 + 2x = 1.02$$

$$2x = 0.02$$

$$x = 0.01$$

Substitute $x = 0.01$ into our approximation for $(1 + 2x)^8$

$$\begin{aligned}(1.02)^8 &= 1 + 16 \times 0.01 + 112 \times (0.01)^2 + 448 \times (0.01)^3 \\ &= 1 + 0.16 + 0.0112 + 0.000448 \\ &= 1.171648\end{aligned}$$

By using a calculator

$$(1.02)^8 = 1.171659$$

Approximation is correct to 4 s.f. (1.172 for both solutions)

Solutionbank C2

Edexcel Modular Mathematics for AS and A-Level

The binomial expansion

Exercise E, Question 1

Question:

When $\left(1 - \frac{3}{2}x\right)^p$ is expanded in ascending powers of x , the coefficient of x is -24 .

- (a) Find the value of p .
 (b) Find the coefficient of x^2 in the expansion.
 (c) Find the coefficient of x^3 in the expansion.

[E]

Solution:

$$\left(1 - \frac{3x}{2}\right)^p = 1 + p \left(-\frac{3x}{2}\right) + \frac{p(p-1)}{2!} \left(-\frac{3x}{2}\right)^2 + \frac{p(p-1)(p-2)}{3!} \left(-\frac{3x}{2}\right)^3 + \dots$$

- (a) Coefficient of x is $-\frac{3p}{2}$

We are given its value is -24

$$\Rightarrow -\frac{3p}{2} = -24$$

$$\Rightarrow p = 16$$

- (b) Coefficient of x^2 is $\frac{p(p-1)}{2} \times \frac{9}{4} = \frac{16 \times 15}{2} \times \frac{9}{4} = 270$

- (c) Coefficient of x^3 is $-\frac{p(p-1)(p-2)}{3!} \times \frac{27}{8} = -\frac{16 \times 15 \times 14}{3!} \times \frac{27}{8} = -1890$

Solutionbank C2

Edexcel Modular Mathematics for AS and A-Level

The binomial expansion

Exercise E, Question 2

Question:

Given that:

$$(2 - x)^{13} \equiv A + Bx + Cx^2 + \dots$$

Find the values of the integers A , B and C .

[E]

Solution:

$$\begin{aligned}(2 - x)^{13} &= 2^{13} + {}^{13}C_1 2^{12}(-x) + {}^{13}C_2 2^{11}(-x)^2 + \dots \\ &= 8192 + 13 \times (-4096x) + 78 \times 2048x^2 + \dots \\ &= 8192 - 53248x + 159744x^2 + \dots \\ &\equiv A + Bx + Cx^2 + \dots\end{aligned}$$

So $A = 8192$, $B = -53248$, $C = 159744$

© Pearson Education Ltd 2008

Solutionbank C2

Edexcel Modular Mathematics for AS and A-Level

The binomial expansion

Exercise E, Question 3

Question:

(a) Expand $(1 - 2x)^{10}$ in ascending powers of x up to and including the term in x^3 , simplifying each coefficient in the expansion.

(b) Use your expansion to find an approximation to $(0.98)^{10}$, stating clearly the substitution which you have used for x .

[E]

Solution:

$$\begin{aligned} \text{(a) } (1 - 2x)^{10} \\ &= 1 + 10 \binom{10}{1} (-2x) + \frac{10 \times 9}{2!} (-2x)^2 + \frac{10 \times 9 \times 8}{3!} (-2x)^3 + \dots \\ &= 1 + 10 \times (-2x) + 45 \times 4x^2 + 120 \times (-8x^3) + \dots \\ &= 1 - 20x + 180x^2 - 960x^3 + \dots \end{aligned}$$

(b) We need $(1 - 2x) = 0.98$

$$\Rightarrow 2x = 0.02$$

$$\Rightarrow x = 0.01$$

Substitute $x = 0.01$ into our expansion for $(1 - 2x)^{10}$

$$(1 - 2 \times 0.01)^{10} = 1 - 20 \times 0.01 + 180 \times 0.01^2 - 960 \times 0.01^3 + \dots$$

$$(0.98)^{10} = 1 - 0.2 + 0.018 - 0.00096 + \dots$$

$$(0.98)^{10} = 0.81704 + \dots$$

$$\text{So } (0.98)^{10} \approx 0.81704$$

Solutionbank C2

Edexcel Modular Mathematics for AS and A-Level

The binomial expansion

Exercise E, Question 4

Question:

(a) Use the binomial series to expand $(2 - 3x)^{10}$ in ascending powers of x up to and including the term in x^3 , giving each coefficient as an integer.

(b) Use your series expansion, with a suitable value for x , to obtain an estimate for 1.97^{10} , giving your answer to 2 decimal places.

[E]

Solution:

$$\begin{aligned}
 \text{(a)} \quad (2 - 3x)^{10} &= 2^{10} + {}^{10}C_1 2^9 (-3x)^1 + {}^{10}C_2 2^8 (-3x)^2 + {}^{10}C_3 2^7 (-3x)^3 + \dots \\
 &= 1024 + 10 \times (-1536x) + 45 \times 2304x^2 + 120 \times (-3456x^3) + \dots \\
 &= 1024 - 15360x + 103680x^2 - 414720x^3 + \dots
 \end{aligned}$$

(b) We require $2 - 3x = 1.97$

$$\Rightarrow 3x = 0.03$$

$$\Rightarrow x = 0.01$$

Substitute $x = 0.01$ in both sides of our expansion of $(2 - 3x)^{10}$

$$\begin{aligned}
 (2 - 3 \times 0.01)^{10} &= 1024 - 15360 \times 0.01 + 103680 \times 0.01^2 - 414720 \times 0.01^3 + \dots \\
 (1.97)^{10} &\approx 1024 - 153.6 + 10.368 - 0.41472 = 880.35328 = 880.35 \text{ (2 d.p.)}
 \end{aligned}$$

Solutionbank C2

Edexcel Modular Mathematics for AS and A-Level

The binomial expansion

Exercise E, Question 5

Question:

- (a) Expand $(3 + 2x)^4$ in ascending powers of x , giving each coefficient as an integer.
- (b) Hence, or otherwise, write down the expansion of $(3 - 2x)^4$ in ascending powers of x .
- (c) Hence by choosing a suitable value for x show that $(3 + 2\sqrt{2})^4 + (3 - 2\sqrt{2})^4$ is an integer and state its value.

[E]

Solution:

- (a) $(3 + 2x)^4$ has coefficients and terms

$$\begin{array}{ccccccc} 1 & 4 & & 6 & & 4 & & 1 \\ 3^4 & 3^3 & (2x) & 3^2 & (2x)^2 & 3 & (2x)^3 & (2x)^4 \end{array}$$

Putting these together gives

$$\begin{aligned} (3 + 2x)^4 &= 1 \times 3^4 + 4 \times 3^3 \times 2x + 6 \times 3^2 \times (2x)^2 + 4 \times 3 \times (2x)^3 + 1 \times (2x)^4 \\ (3 + 2x)^4 &= 81 + 216x + 216x^2 + 96x^3 + 16x^4 \end{aligned}$$

$$\begin{aligned} (b) \quad (3 - 2x)^4 &= 1 \times 3^4 + 4 \times 3^3 \times (-2x) + 6 \times 3^2 \times (-2x)^2 + 4 \times 3 \times (-2x)^3 + 1 \times (-2x)^4 \\ (3 - 2x)^4 &= 81 - 216x + 216x^2 - 96x^3 + 16x^4 \end{aligned}$$

- (c) Using parts (a) and (b)

$$(3 + 2x)^4 + (3 - 2x)^4 =$$

$$\begin{array}{r} 81 + 216x + 216x^2 + 96x^3 + 16x^4 \\ + 81 - 216x + 216x^2 - 96x^3 + 16x^4 \\ \hline 162 \qquad \qquad + 432x^2 \qquad \qquad + 32x^4 \end{array}$$

Substituting $x = \sqrt{2}$ into both sides of this expansion gives

$$\begin{aligned} (3 + 2\sqrt{2})^4 + (3 - 2\sqrt{2})^4 &= 162 + 432(\sqrt{2})^2 + 32(\sqrt{2})^4 \\ &= 162 + 432 \times 2 + 32 \times 4 = 162 + 864 + 128 = 1154 \end{aligned}$$

Solutionbank C2

Edexcel Modular Mathematics for AS and A-Level

The binomial expansion

Exercise E, Question 6

Question:

The coefficient of x^2 in the binomial expansion of $\left(1 + \frac{x}{2}\right)^n$, where n is a positive integer, is 7.

(a) Find the value of n .

(b) Using the value of n found in part (a), find the coefficient of x^4 .

[E]

Solution:

$$\left(1 + \frac{x}{2}\right)^n = 1 + n \left(\frac{x}{2}\right) + \frac{n(n-1)}{2!} \left(\frac{x}{2}\right)^2 + \frac{n(n-1)(n-2)}{3!} \left(\frac{x}{2}\right)^3 + \frac{n(n-1)(n-2)(n-3)}{4!} \left(\frac{x}{2}\right)^4 + \dots$$

(a) We are told the coefficient of x^2 is 7

$$\Rightarrow \frac{n(n-1)}{2} \times \frac{1}{4} = 7$$

$$\Rightarrow n(n-1) = 56$$

$$\Rightarrow n^2 - n - 56 = 0$$

$$\Rightarrow (n-8)(n+7) = 0$$

$$\Rightarrow n = 8$$

(b) Coefficient of x^4 is

$$\frac{n(n-1)(n-2)(n-3)}{4!} \times \frac{1}{2^4} = \frac{8 \times 7 \times \overset{2}{\cancel{6}} \times 5}{\cancel{4} \times \cancel{3} \times 2 \times 1} \times \frac{1}{\cancel{16}} = \frac{35}{8}$$

Solutionbank C2

Edexcel Modular Mathematics for AS and A-Level

The binomial expansion

Exercise E, Question 7

Question:

- (a) Use the binomial theorem to expand $(3 + 10x)^4$ giving each coefficient as an integer.
- (b) Use your expansion, with an appropriate value for x , to find the exact value of $(1003)^4$. State the value of x which you have used.

[E]

Solution:

$$\begin{aligned}
 \text{(a) } (3 + 10x)^4 &= 3^4 + {}^4C_1 3^3 (10x) + {}^4C_2 (3)^2 (10x)^2 + {}^4C_3 (3)^1 (10x)^3 + (10x)^4 \\
 &= 3^4 + 4 \times 270x + 6 \times 900x^2 + 4 \times 3000x^3 + 10000x^4 \\
 &= 81 + 1080x + 5400x^2 + 12000x^3 + 10000x^4
 \end{aligned}$$

$$\text{(b) We require } 1003 = 3 + 10x$$

$$\Rightarrow 1000 = 10x$$

$$\Rightarrow 100 = x$$

Substitute $x = 100$ in both sides of our expansion

$$(3 + 10 \times 100)^4 = 81 + 1080 \times 100 + 5400 \times 100^2 + 12000 \times 100^3 + 10000 \times 100^4$$

$$(1003)^4 = 81 + 108\,000 + 54\,000\,000 + 12\,000\,000\,000 + 1\,000\,000\,000\,000$$

$$(1003)^4 =$$

$$\begin{array}{r}
 1\,000\,000\,000\,000 \\
 12\,000\,000\,000 \\
 54\,000\,000 \\
 108\,000 \\
 81 \\
 \hline
 1\,012\,054\,108\,081
 \end{array}$$

Solutionbank C2

Edexcel Modular Mathematics for AS and A-Level

The binomial expansion

Exercise E, Question 8

Question:

- (a) Expand $(1 + 2x)^{12}$ in ascending powers of x up to and including the term in x^3 , simplifying each coefficient.
- (b) By substituting a suitable value for x , which must be stated, into your answer to part (a), calculate an approximate value of $(1.02)^{12}$.
- (c) Use your calculator, writing down all the digits in your display, to find a more exact value of $(1.02)^{12}$.
- (d) Calculate, to 3 significant figures, the percentage error of the approximation found in part (b).

[E]

Solution:

$$\begin{aligned} \text{(a)} \quad & (1 + 2x)^{12} \\ &= 1 + 12 \binom{12}{1} (2x)^1 + \frac{12 \times 11}{2!} (2x)^2 + \frac{12 \times 11 \times 10}{3!} (2x)^3 + \dots \\ &= 1 + 24x + 264x^2 + 1760x^3 + \dots \end{aligned}$$

$$\begin{aligned} \text{(b)} \quad & \text{We require } 1 + 2x = 1.02 \\ & \Rightarrow 2x = 0.02 \\ & \Rightarrow x = 0.01 \end{aligned}$$

Substitute $x = 0.01$ in both sides of expansion

$$\begin{aligned} (1 + 2 \times 0.01)^{12} &= 1 + 24 \times 0.01 + 264 \times 0.01^2 + 1760 \times 0.01^3 \\ (1.02)^{12} &= 1 + 0.24 + 0.0264 + 0.00176 \\ (1.02)^{12} &= 1.26816 \end{aligned}$$

$$\begin{aligned} \text{(c)} \quad & \text{Using a calculator} \\ (1.02)^{12} &= 1.268241795 \end{aligned}$$

$$\text{(d)} \quad \% \text{ error} = \frac{|\text{Answer b} - \text{Answer c}|}{\text{Answer c}} \times 100$$

$$\% \text{ error} = 0.006449479$$

$$\% \text{ error} = 0.00645 \%$$

Solutionbank C2

Edexcel Modular Mathematics for AS and A-Level

The binomial expansion

Exercise E, Question 9

Question:

Expand $\left(x - \frac{1}{x}\right)^5$, simplifying the coefficients.

[E]

Solution:

$\left(x - \frac{1}{x}\right)^5$ has coefficients and terms

$${}^1_5 x^5 \quad {}^{10}_4 x^4 \left(-\frac{1}{x}\right) \quad {}^{10}_3 x^3 \left(-\frac{1}{x}\right)^2 \quad {}^5_2 x^2 \left(-\frac{1}{x}\right)^3 \quad {}^1_1 x \left(-\frac{1}{x}\right)^4 \quad \left(-\frac{1}{x}\right)^5$$

Putting these together gives

$$\left(x - \frac{1}{x}\right)^5 = 1x^5 + 5x^4 \left(-\frac{1}{x}\right) + 10x^3 \left(-\frac{1}{x}\right)^2 + 10x^2 \left(-\frac{1}{x}\right)^3 + 5x \left(-\frac{1}{x}\right)^4 + 1 \left(-\frac{1}{x}\right)^5$$

$$\left(x - \frac{1}{x}\right)^5 = x^5 - 5x^3 + 10x - \frac{10}{x} + \frac{5}{x^3} - \frac{1}{x^5}$$

Solutionbank C2

Edexcel Modular Mathematics for AS and A-Level

The binomial expansion

Exercise E, Question 10

Question:

In the binomial expansion of $(2k + x)^n$, where k is a constant and n is a positive integer, the coefficient of x^2 is equal to the coefficient of x^3 .

(a) Prove that $n = 6k + 2$.

(b) Given also that $k = \frac{2}{3}$, expand $(2k + x)^n$ in ascending powers of x up to and including the term in x^3 , giving each coefficient as an exact fraction in its simplest form.

[E]

Solution:

$$(a) (2k + x)^n = (2k)^n + {}^n C_1 (2k)^{n-1}x + {}^n C_2 (2k)^{n-2}x^2 + {}^n C_3 (2k)^{n-3}x^3 + \dots$$

Coefficient of $x^2 =$ coefficient of x^3

$${}^n C_2 (2k)^{n-2} = {}^n C_3 (2k)^{n-3}$$

$$\frac{n!}{(n-2)!2!} (2k)^{n-2} = \frac{n!}{(n-3)!3!} (2k)^{n-3}$$

$$\frac{(2k)^{n-2}}{(2k)^{n-3}} = \frac{(n-2)!2!}{(n-3)!3!} \quad (\text{Use laws of indices})$$

$$(2k)^1 = \frac{(n-2)!2!}{(n-3)!3!} \left[(n-2)! = (n-2) \times (n-3)! \right]$$

$$2k = \frac{(n-2) \times 2}{3}$$

$$3 \times 2k = n - 2$$

$$6k = n - 2$$

$$n = 6k + 2$$

(b) If $k = \frac{2}{3}$ then $n = 6 \times \frac{2}{3} + 2 = 6$

Expression is

$$\left(2 \times \frac{2}{3} + x \right)^6$$

$$= \left(\frac{4}{3} + x \right)^6$$

$$= \left(\frac{4}{3} \right)^6 + {}^6 C_1 \left(\frac{4}{3} \right)^5 x^1 + {}^6 C_2 \left(\frac{4}{3} \right)^4 x^2 + {}^6 C_3 \left(\frac{4}{3} \right)^3 x^3 + \dots$$

$$= \frac{4096}{729} + \frac{2048}{81}x + \frac{1280}{27}x^2 + \frac{1280}{27}x^3 + \dots$$

Solutionbank C2

Edexcel Modular Mathematics for AS and A-Level

The binomial expansion

Exercise E, Question 11

Question:

(a) Expand $(2 + x)^6$ as a binomial series in ascending powers of x , giving each coefficient as an integer.

(b) By making suitable substitutions for x in your answer to part (a), show that $(2 + \sqrt{3})^6 - (2 - \sqrt{3})^6$ can be simplified to the form $k\sqrt{3}$, stating the value of the integer k .

[E]

Solution:

$$\begin{aligned} \text{(a) } (2 + x)^6 &= 2^6 + {}^6C_1 2^5 x + {}^6C_2 2^4 x^2 + {}^6C_3 2^3 x^3 + {}^6C_4 2^2 x^4 + {}^6C_5 2x^5 + x^6 \\ &= 64 + 192x + 240x^2 + 160x^3 + 60x^4 + 12x^5 + x^6 \end{aligned}$$

(b) With $x = \sqrt{3}$

$$(2 + \sqrt{3})^6 = 64 + 192\sqrt{3} + 240(\sqrt{3})^2 + 160(\sqrt{3})^3 + 60(\sqrt{3})^4 + 12(\sqrt{3})^5 + (\sqrt{3})^6 \quad \textcircled{1}$$

with $x = -\sqrt{3}$

$$(2 - \sqrt{3})^6 = 64 + 192(-\sqrt{3}) + 240(-\sqrt{3})^2 + 160(-\sqrt{3})^3 + 60(-\sqrt{3})^4 + 12(-\sqrt{3})^5 + (-\sqrt{3})^6$$

$$(2 - \sqrt{3})^6 = 64 - 192\sqrt{3} + 240(\sqrt{3})^2 - 160(\sqrt{3})^3 + 60(\sqrt{3})^4 - 12(\sqrt{3})^5 + (\sqrt{3})^6 \quad \textcircled{2}$$

$\textcircled{1} - \textcircled{2}$ gives

$$\begin{aligned} (2 + \sqrt{3})^6 - (2 - \sqrt{3})^6 &= 384\sqrt{3} + 320(\sqrt{3})^3 + 24(\sqrt{3})^5 \\ &= 384\sqrt{3} + 320 \times 3\sqrt{3} + 24 \times 3 \times 3\sqrt{3} \\ &= 384\sqrt{3} + 960\sqrt{3} + 216\sqrt{3} \\ &= 1560\sqrt{3} \end{aligned}$$

Hence $k = 1560$

Solutionbank C2

Edexcel Modular Mathematics for AS and A-Level

The binomial expansion

Exercise E, Question 12

Question:

The coefficient of x^2 in the binomial expansion of $(2 + kx)^8$, where k is a positive constant, is 2800.

- (a) Use algebra to calculate the value of k .
- (b) Use your value of k to find the coefficient of x^3 in the expansion.

[E]

Solution:

(a) The term in x^2 of $(2 + kx)^8$ is
 ${}^8C_2 2^6 (kx)^2 = 28 \times 64k^2x^2 = 1792k^2x^2$

Hence $1792k^2 = 2800$

$$k^2 = 1.5625$$

$$k = \pm 1.25$$

Since k is positive $k = 1.25$.

(b) Term in x^3 of $(2 + kx)^8$ is

$${}^8C_3 2^5 (kx)^3 = 56 \times 32k^3x^3$$

Coefficient of x^3 term is $1792k^3 = 1792 \times 1.25^3 = 3500$

Solutionbank C2

Edexcel Modular Mathematics for AS and A-Level

The binomial expansion

Exercise E, Question 13

Question:

(a) Given that

$$(2+x)^5 + (2-x)^5 \equiv A + Bx^2 + Cx^4,$$

find the value of the constants A , B and C .

(b) Using the substitution $y = x^2$ and your answers to part (a), solve

$$(2+x)^5 + (2-x)^5 = 349.$$

[E]

Solution:

(a) $(2+x)^5$ will have coefficients and terms

$$\begin{array}{cccccc} 1 & 5 & 10 & 10 & 5 & 1 \\ 2^5 & 2^4x & 2^3x^2 & 2^2x^3 & 2x^4 & x^5 \end{array}$$

Putting these together we get

$$(2+x)^5 = 1 \times 2^5 + 5 \times 2^4x + 10 \times 2^3x^2 + 10 \times 2^2x^3 + 5 \times 2x^4 + 1 \times x^5$$

$$(2+x)^5 = 32 + 80x + 80x^2 + 40x^3 + 10x^4 + x^5$$

Therefore

$$(2-x)^5 = 32 - 80x + 80x^2 - 40x^3 + 10x^4 - x^5$$

$$\text{Adding } (2+x)^5 + (2-x)^5 = 64 + 160x^2 + 20x^4$$

$$\text{So } A = 64, B = 160, C = 20$$

(b) $(2+x)^5 + (2-x)^5 = 349$

$$64 + 160x^2 + 20x^4 = 349$$

$$20x^4 + 160x^2 - 285 = 0 \quad (\div 5)$$

$$4x^4 + 32x^2 - 57 = 0$$

Substitute $y = x^2$

$$4y^2 + 32y - 57 = 0$$

$$(2y-3)(2y+19) = 0$$

$$y = \frac{3}{2}, -\frac{19}{2}$$

$$\text{But } y = x^2, \text{ so } x^2 = \frac{3}{2} \Rightarrow x = \pm \sqrt{\frac{3}{2}}$$

Solutionbank C2

Edexcel Modular Mathematics for AS and A-Level

The binomial expansion

Exercise E, Question 14

Question:

In the binomial expansion of $(2 + px)^5$, where p is a constant, the coefficient of x^3 is 135. Calculate:

- (a) The value of p ,
- (b) The value of the coefficient of x^4 in the expansion.

[E]

Solution:

(a) The term in x^3 in the expansion of $(2 + px)^5$ is

$${}^5C_3 2^2 (px)^3 = 10 \times 4p^3 x^3 = 40p^3 x^3$$

We are given the coefficient is 135 so

$$40p^3 = 135 \quad (\div 40)$$

$$p^3 = 3.375 \quad \left(\sqrt[3]{\quad} \right)$$

$$p = 1.5$$

(b) The term in x^4 in the expansion of $(2 + px)^5$ is

$${}^5C_4 2^1 (px)^4 = 5 \times 2p^4 x^4 = 5 \times 2(1.5)^4 x^4 = 50.625x^4$$

Coefficient of x^4 is 50.625

Solutionbank C2

Edexcel Modular Mathematics for AS and A-Level

Radian measure and its applications

Exercise A, Question 1

Question:

Convert the following angles in radians to degrees:

(a) $\frac{\pi}{20}$

(b) $\frac{\pi}{15}$

(c) $\frac{5\pi}{12}$

(d) $\frac{\pi}{2}$

(e) $\frac{7\pi}{9}$

(f) $\frac{7\pi}{6}$

(g) $\frac{5\pi}{4}$

(h) $\frac{3\pi}{2}$

(i) 3π

Solution:

(a) $\frac{\pi}{20} \text{ rad} = \frac{180^\circ}{20} = 9^\circ$

(b) $\frac{\pi}{15} \text{ rad} = \frac{180^\circ}{15} = 12^\circ$

(c) $\frac{5\pi}{12} \text{ rad} = \frac{5 \times 180^\circ}{12} = 75^\circ$

(d) $\frac{\pi}{2} \text{ rad} = \frac{180^\circ}{2} = 90^\circ$

(e) $\frac{7\pi}{9} \text{ rad} = \frac{7 \times 180^\circ}{9} = 140^\circ$

$$(f) \frac{7\pi}{6} \text{ rad} = \frac{7 \times 180^\circ}{6} = 210^\circ$$

$$(g) \frac{5\pi}{4} \text{ rad} = \frac{5 \times 180^\circ}{4} = 225^\circ$$

$$(h) \frac{3\pi}{2} \text{ rad} = 3 \times 90^\circ = 270^\circ$$

$$(i) 3\pi \text{ rad} = 3 \times 180^\circ = 540^\circ$$

© Pearson Education Ltd 2008

Solutionbank C2

Edexcel Modular Mathematics for AS and A-Level

Radian measure and its applications

Exercise A, Question 2

Question:

Use your calculator to convert the following angles to degrees, giving your answer to the nearest 0.1° :

(a) 0.46°

(b) 1°

(c) 1.135°

(d) $\sqrt{3}^\circ$

(e) 2.5°

(f) 3.14°

(g) 3.49°

Solution:

(a) $0.46^\circ = 26.356 \dots^\circ = 26.4^\circ$ (nearest 0.1°)

(b) $1^\circ = 57.295 \dots^\circ = 57.3^\circ$ (nearest 0.1°)

(c) $1.135^\circ = 65.030 \dots^\circ = 65.0^\circ$ (nearest 0.1°)

(d) $\sqrt{3}^\circ = 99.239 \dots^\circ = 99.2^\circ$ (nearest 0.1°)

(e) $2.5^\circ = 143.239 \dots^\circ = 143.2^\circ$ (nearest 0.1°)

(f) $3.14^\circ = 179.908 \dots^\circ = 179.9^\circ$ (nearest 0.1°)

(g) $3.49^\circ = 199.96 \dots^\circ = 200.0^\circ$ (nearest 0.1°)

© Pearson Education Ltd 2008

Solutionbank C2

Edexcel Modular Mathematics for AS and A-Level

Radian measure and its applications

Exercise A, Question 3

Question:

Use your calculator to write down the value, to 3 significant figures, of the following trigonometric functions.

(a) $\sin 0.5^\circ$

(b) $\cos \sqrt{2}^\circ$

(c) $\tan 1.05^\circ$

(d) $\sin 2^\circ$

(e) $\cos 3.6^\circ$

Solution:

(a) $\sin 0.5^\circ = 0.47942 \dots = 0.479$ (3 s.f.)

(b) $\cos \sqrt{2}^\circ = 0.1559 \dots = 0.156$ (3 s.f.)

(c) $\tan 1.05^\circ = 1.7433 \dots = 1.74$ (3 s.f.)

(d) $\sin 2^\circ = 0.90929 \dots = 0.909$ (3 s.f.)

(e) $\cos 3.6^\circ = -0.8967 \dots = -0.897$ (3 s.f.)

Solutionbank C2

Edexcel Modular Mathematics for AS and A-Level

Radian measure and its applications

Exercise A, Question 4

Question:

Convert the following angles to radians, giving your answers as multiples of π .

(a) 8°

(b) 10°

(c) 22.5°

(d) 30°

(e) 45°

(f) 60°

(g) 75°

(h) 80°

(i) 112.5°

(j) 120°

(k) 135°

(l) 200°

(m) 240°

(n) 270°

(o) 315°

(p) 330°

Solution:

$$(a) 8^\circ = 8 \times \frac{\pi}{180} \text{ rad} = \frac{2\pi}{45} \text{ rad}$$

$$(b) 10^\circ = 10 \times \frac{\pi}{180} \text{ rad} = \frac{\pi}{18} \text{ rad}$$

$$(c) 22.5^\circ = 22.5 \times \frac{\pi}{180} \text{ rad} = \frac{\pi}{8} \text{ rad}$$

$$(d) 30^\circ = 30 \times \frac{\pi}{180} \text{ rad} = \frac{\pi}{6} \text{ rad}$$

$$(e) 45^\circ = 45 \times \frac{\pi}{180} \text{ rad} = \frac{\pi}{4} \text{ rad}$$

$$(f) 60^\circ = 2 \times \text{answer to (d)} = \frac{\pi}{3} \text{ rad}$$

$$(g) 75^\circ = \frac{75}{12} \times \frac{\pi}{180} \text{ rad} = \frac{5\pi}{12} \text{ rad}$$

$$(h) 80^\circ = \frac{80}{9} \times \frac{\pi}{180} \text{ rad} = \frac{4\pi}{9} \text{ rad}$$

$$(i) 112.5^\circ = 5 \times \text{answer to (c)} = \frac{5\pi}{8} \text{ rad}$$

$$(j) 120^\circ = 2 \times \text{answer to (f)} = \frac{2\pi}{3} \text{ rad}$$

$$(k) 135^\circ = 3 \times \text{answer to (e)} = \frac{3\pi}{4} \text{ rad}$$

$$(l) 200^\circ = \frac{200}{9} \times \frac{\pi}{180} \text{ rad} = \frac{10\pi}{9} \text{ rad}$$

$$(m) 240^\circ = 2 \times \text{answer to (j)} = \frac{4\pi}{3} \text{ rad}$$

$$(n) 270^\circ = 3 \times 90^\circ = \frac{3\pi}{2} \text{ rad}$$

$$(o) 315^\circ = 180^\circ + 135^\circ = \pi + \frac{3\pi}{4} = \frac{7\pi}{4} \text{ rad}$$

$$(p) 330^\circ = 11 \times 30^\circ = \frac{11\pi}{6} \text{ rad}$$

Solutionbank C2

Edexcel Modular Mathematics for AS and A-Level

Radian measure and its applications

Exercise A, Question 5

Question:

Use your calculator to convert the following angles to radians, giving your answers to 3 significant figures:

(a) 50°

(b) 75°

(c) 100°

(d) 160°

(e) 230°

(f) 320°

Solution:

(a) $50^\circ = 0.8726 \dots \text{ rad} = 0.873^\circ \text{ (3 s.f.)}$

(b) $75^\circ = 1.3089 \dots \text{ rad} = 1.31^\circ \text{ (3 s.f.)}$

(c) $100^\circ = 1.7453 \dots \text{ rad} = 1.75^\circ \text{ (3 s.f.)}$

(d) $160^\circ = 2.7925 \dots \text{ rad} = 2.79^\circ \text{ (3 s.f.)}$

(e) $230^\circ = 4.01425 \dots \text{ rad} = 4.01^\circ \text{ (3 s.f.)}$

(f) $320^\circ = 5.585 \dots \text{ rad} = 5.59^\circ \text{ (3 s.f.)}$

Solutionbank C2

Edexcel Modular Mathematics for AS and A-Level

Radian measure and its applications

Exercise B, Question 1

Question:

An arc AB of a circle, centre O and radius r cm, subtends an angle θ radians at O . The length of AB is l cm.

(a) Find l when

(i) $r = 6, \theta = 0.45$

(ii) $r = 4.5, \theta = 0.45$

(iii) $r = 20, \theta = \frac{3}{8}\pi$

(b) Find r when

(i) $l = 10, \theta = 0.6$

(ii) $l = 1.26, \theta = 0.7$

(iii) $l = 1.5\pi, \theta = \frac{5}{12}\pi$

(c) Find θ when

(i) $l = 10, r = 7.5$

(ii) $l = 4.5, r = 5.625$

(iii) $l = \sqrt{12}, r = \sqrt{3}$

Solution:

(a) Using $l = r\theta$

(i) $l = 6 \times 0.45 = 2.7$

(ii) $l = 4.5 \times 0.45 = 2.025$

(iii) $l = 20 \times \frac{3}{8}\pi = 7.5\pi$ (23.6 3 s.f.)

(b) Using $r = \frac{l}{\theta}$

(i) $r = \frac{10}{0.6} = 16 \frac{2}{3}$

(ii) $r = \frac{1.26}{0.7} = 1.8$

(iii) $r = \frac{1.5\pi}{\frac{5}{12}\pi} = 1.5 \times \frac{12}{5} = \frac{18}{5} = 3 \frac{3}{5}$

(c) Using $\theta = \frac{l}{r}$

(i) $\theta = \frac{10}{7.5} = 1 \frac{1}{3}$

(ii) $\theta = \frac{4.5}{5.625} = 0.8$

(iii) $\theta = \frac{\sqrt{12}}{\sqrt{3}} = \frac{2\sqrt{3}}{\sqrt{3}} = 2$

Solutionbank C2

Edexcel Modular Mathematics for AS and A-Level

Radian measure and its applications

Exercise B, Question 2

Question:

A minor arc AB of a circle, centre O and radius 10 cm, subtends an angle x at O . The major arc AB subtends an angle $5x$ at O . Find, in terms of π , the length of the minor arc AB .

Solution:

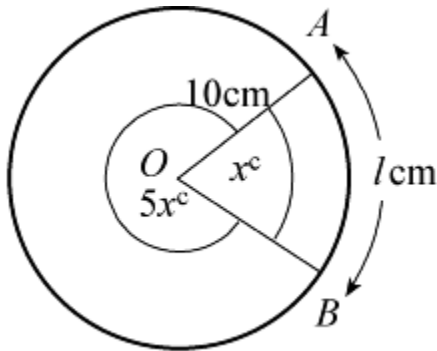

The total angle at the centre is $6x^\circ$ so
 $6x = 2\pi$

$$x = \frac{\pi}{3}$$

Using $l = r\theta$ to find minor arc AB

$$l = 10 \times \frac{\pi}{3} = \frac{10\pi}{3} \text{ cm}$$

Solutionbank C2

Edexcel Modular Mathematics for AS and A-Level

Radian measure and its applications

Exercise B, Question 3

Question:

An arc AB of a circle, centre O and radius 6 cm, has length l cm. Given that the chord AB has length 6 cm, find the value of l , giving your answer in terms of π .

Solution:

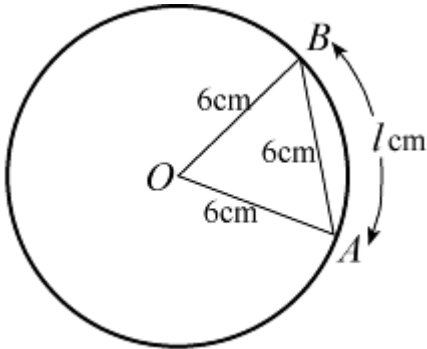

$\triangle OAB$ is equilateral, so $\angle AOB = \frac{\pi}{3}$ rad.

Using $l = r\theta$

$$l = 6 \times \frac{\pi}{3} = 2\pi$$

Solutionbank C2

Edexcel Modular Mathematics for AS and A-Level

Radian measure and its applications

Exercise B, Question 4

Question:

The sector of a circle of radius $\sqrt{10}$ cm contains an angle of $\sqrt{5}$ radians, as shown in the diagram. Find the length of the arc, giving your answer in the form $p\sqrt{q}$ cm, where p and q are integers.

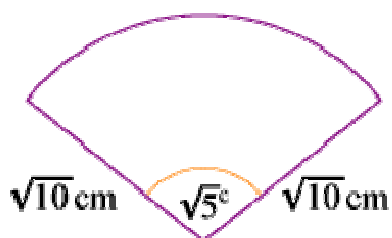

Solution:

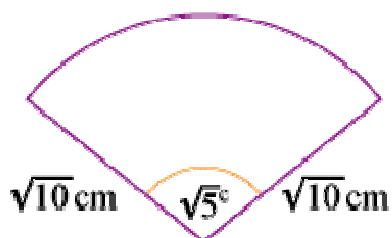

Using $l = r\theta$ with $r = \sqrt{10}$ cm and $\theta = \sqrt{5}$
 $l = \sqrt{10} \times \sqrt{5} = \sqrt{50} = \sqrt{25 \times 2} = 5\sqrt{2}$ cm

© Pearson Education Ltd 2008

Solutionbank C2

Edexcel Modular Mathematics for AS and A-Level

Radian measure and its applications

Exercise B, Question 5

Question:

Referring to the diagram, find:

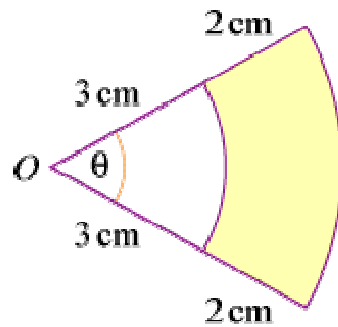

- (a) The perimeter of the shaded region when $\theta = 0.8$ radians.
 (b) The value of θ when the perimeter of the shaded region is 14 cm .

Solution:

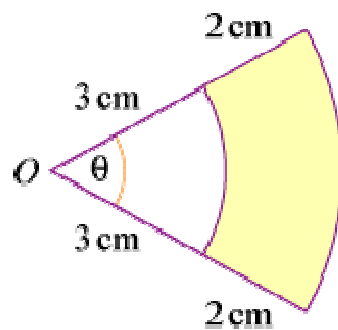

- (a) Using $l = r\theta$,
 the smaller arc $= 3 \times 0.8 = 2.4\text{ cm}$
 the larger arc $= (3 + 2) \times 0.8 = 4\text{ cm}$
 Perimeter $= 2.4\text{ cm} + 2\text{ cm} + 4\text{ cm} + 2\text{ cm} = 10.4\text{ cm}$

- (b) The smaller arc $= 3\theta\text{ cm}$, the larger arc $= 5\theta\text{ cm}$.
 So perimeter $= (3\theta + 5\theta + 2 + 2)\text{ cm}$.
 As perimeter is 14 cm ,
 $8\theta + 4 = 14$
 $8\theta = 10$
 $\theta = \frac{10}{8} = 1\frac{1}{4}$

Solutionbank C2

Edexcel Modular Mathematics for AS and A-Level

Radian measure and its applications

Exercise B, Question 6

Question:

A sector of a circle of radius r cm contains an angle of 1.2 radians. Given that the sector has the same perimeter as a square of area 36 cm^2 , find the value of r .

Solution:

Using $l = r\theta$, the arc length = $1.2r$ cm.

The area of the square = 36 cm^2 , so each side = 6 cm and the perimeter is, therefore, 24 cm.

The perimeter of the sector = arc length + $2r$ cm = $(1.2r + 2r)$ cm = $3.2r$ cm.

The perimeter of square = perimeter of sector so

$$24 = 3.2r$$

$$r = \frac{24}{3.2} = 7.5$$

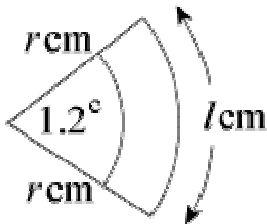

© Pearson Education Ltd 2008

Solutionbank C2

Edexcel Modular Mathematics for AS and A-Level

Radian measure and its applications

Exercise B, Question 7

Question:

A sector of a circle of radius 15 cm contains an angle of θ radians. Given that the perimeter of the sector is 42 cm, find the value of θ .

Solution:

Using $l = r\theta$, the arc length of the sector = 15θ cm.

So the perimeter = $(15\theta + 30)$ cm.

As the perimeter = 42 cm

$$15\theta + 30 = 42$$

$$\Rightarrow 15\theta = 12$$

$$\Rightarrow \theta = \frac{12}{15} = \frac{4}{5}$$

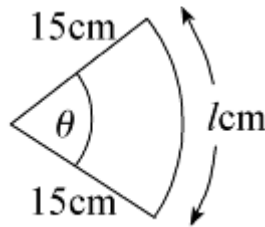

Solutionbank C2

Edexcel Modular Mathematics for AS and A-Level

Radian measure and its applications

Exercise B, Question 8

Question:

In the diagram AB is the diameter of a circle, centre O and radius 2 cm. The point C is on the circumference such that $\angle COB = \frac{2}{3}\pi$ radians.

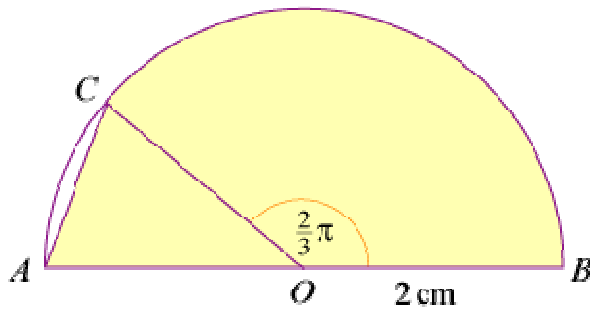

(a) State the value, in radians, of $\angle COA$.

The shaded region enclosed by the chord AC , arc CB and AB is the template for a brooch.

(b) Find the exact value of the perimeter of the brooch.

Solution:

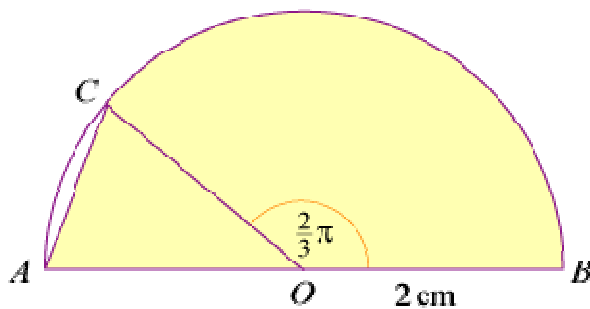

(a) $\angle COA = \pi - \frac{2}{3}\pi = \frac{\pi}{3}$ rad

(b) The perimeter of the brooch = AB + arc BC + chord AC .
 $AB = 4$ cm

arc $BC = r\theta$ with $r = 2$ cm and $\theta = \frac{2}{3}\pi$ so

arc $BC = 2 \times \frac{2}{3}\pi = \frac{4}{3}\pi$ cm

As $\angle COA = \frac{\pi}{3}$ (60°), $\triangle COA$ is equilateral, so

chord $AC = 2$ cm

The perimeter = 4 cm + $\frac{4}{3}\pi$ cm + 2 cm = $\left(6 + \frac{4}{3}\pi\right)$ cm

Solutionbank C2

Edexcel Modular Mathematics for AS and A-Level

Radian measure and its applications

Exercise B, Question 9

Question:

The points A and B lie on the circumference of a circle with centre O and radius 8.5 cm. The point C lies on the major arc AB . Given that $\angle ACB = 0.4$ radians, calculate the length of the minor arc AB .

Solution:

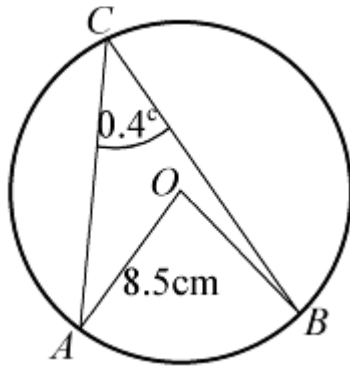

Using the circle theorem:

Angle subtended at the centre of the circle $= 2 \times$ angle subtended at the circumference

$$\angle AOB = 2 \angle ACB = 0.8^\circ$$

Using $l = r\theta$

$$\text{length of minor arc } AB = 8.5 \times 0.8 \text{ cm} = 6.8 \text{ cm}$$

Solutionbank C2

Edexcel Modular Mathematics for AS and A-Level

Radian measure and its applications

Exercise B, Question 10

Question:

In the diagram OAB is a sector of a circle, centre O and radius R cm, and $\angle AOB = 2\theta$ radians. A circle, centre C and radius r cm, touches the arc AB at T , and touches OA and OB at D and E respectively, as shown.

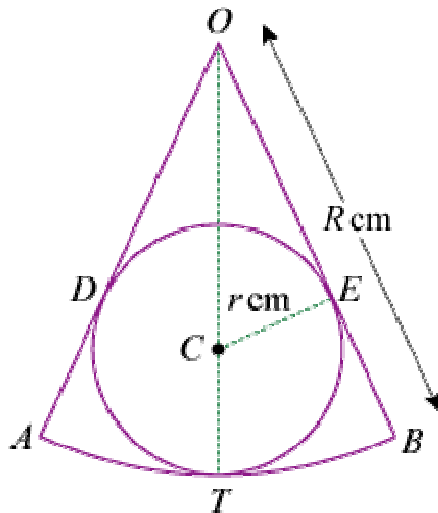

(a) Write down, in terms of R and r , the length of OC .

(b) Using $\triangle OCE$, show that $R \sin \theta = r (1 + \sin \theta)$.

(c) Given that $\sin \theta = \frac{3}{4}$ and that the perimeter of the sector OAB is 21 cm, find r , giving your answer to 3 significant figures.

Solution:

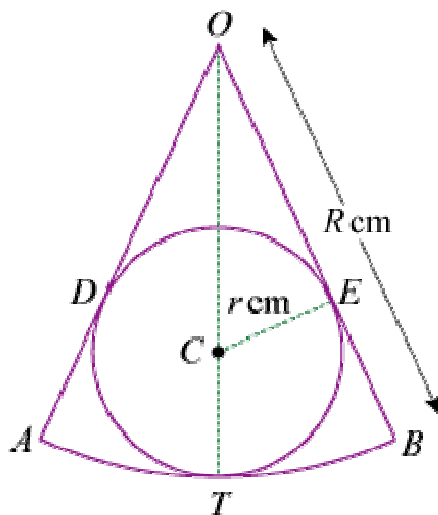

(a) $OC = OT - CT = R \text{ cm} - r \text{ cm} = (R - r) \text{ cm}$

(b) In $\triangle OCE$, $\angle CEO = 90^\circ$ (radius perpendicular to tangent)

and $\angle COE = \theta$ (OT bisects $\angle AOB$)

Using $\sin \angle COE = \frac{CE}{OC}$

$$\sin \theta = \frac{r}{R-r}$$

$$(R-r) \sin \theta = r$$

$$R \sin \theta - r \sin \theta = r$$

$$R \sin \theta = r + r \sin \theta$$

$$R \sin \theta = r(1 + \sin \theta)$$

(c) As $\sin \theta = \frac{3}{4}$, $\frac{3}{4}R = \frac{7}{4}r \Rightarrow R = \frac{7}{3}r$

and $\theta = \sin^{-1} \frac{3}{4} = 0.84806 \dots^\circ$

The perimeter of the sector = $2R + 2R\theta = 2R \left(1 + \theta \right) = \frac{14}{3}r \left(1.84806 \dots \right)$

So $21 = \frac{14}{3}r \left(1.84806 \dots \right)$

$$\Rightarrow r = \frac{21 \times 3}{14(1.84806 \dots)} = \frac{9}{2(1.84806 \dots)} = 2.43 \text{ (3 s.f.)}$$

Solutionbank C2

Edexcel Modular Mathematics for AS and A-Level

Radian measure and its applications

Exercise C, Question 1

Question:

(Note: give non-exact answers to 3 significant figures.)

Find the area of the shaded sector in each of the following circles with centre C . Leave your answer in terms of π , where appropriate.

(a)

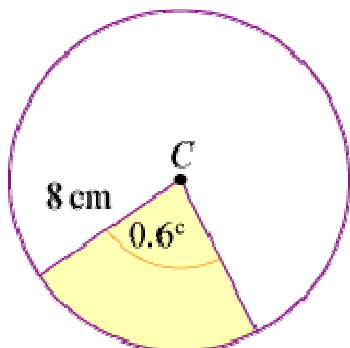

(b)

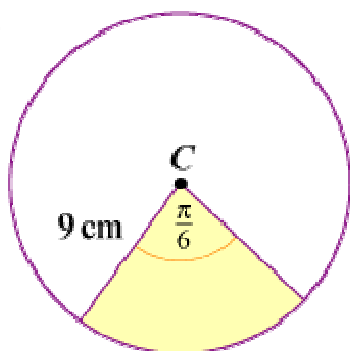

(c)

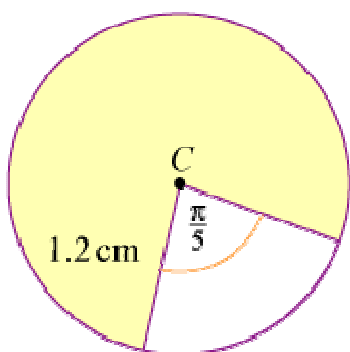

(d)

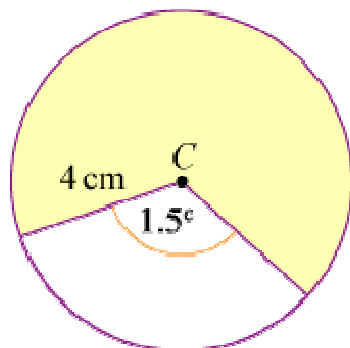

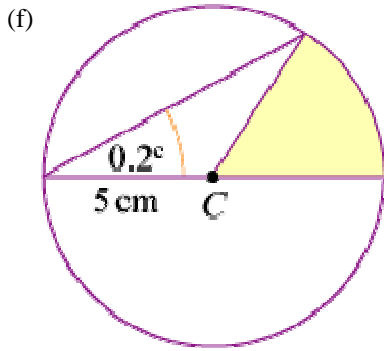
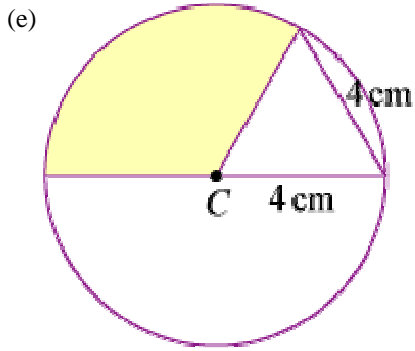

Solution:

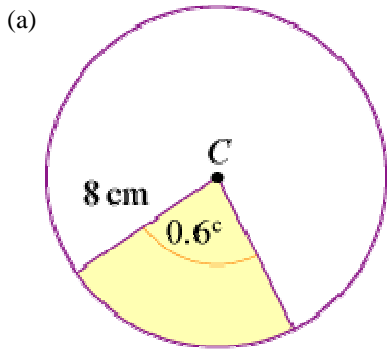

Area of shaded sector = $\frac{1}{2} \times 8^2 \times 0.6 = 19.2 \text{ cm}^2$

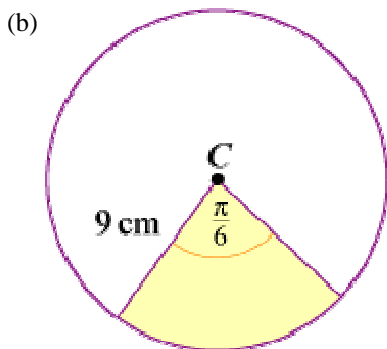

Area of shaded sector = $\frac{1}{2} \times 9^2 \times \frac{\pi}{6} = \frac{27\pi}{4} \text{ cm}^2 = 6.75\pi \text{ cm}^2$

(c)

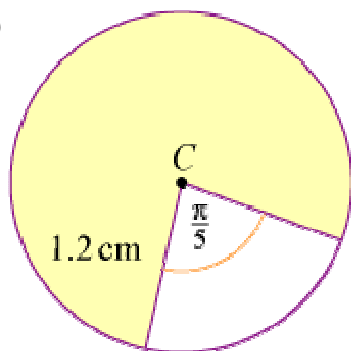

Angle subtended at C by major arc $= 2\pi - \frac{\pi}{5} = \frac{9\pi}{5}$ rad

Area of shaded sector $= \frac{1}{2} \times 1.2^2 \times \frac{9\pi}{5} = 1.296\pi$ cm²

(d)

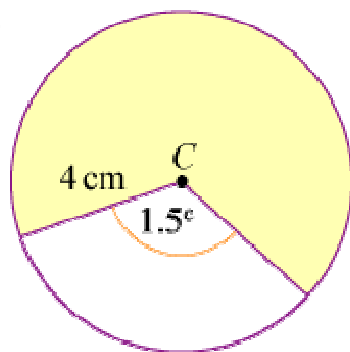

Angle subtended at C by major arc $= (2\pi - 1.5)$ rad

Area of shaded sector $= \frac{1}{2} \times 4^2 \times (2\pi - 1.5) = 38.3$ cm² (3 s.f.)

(e)

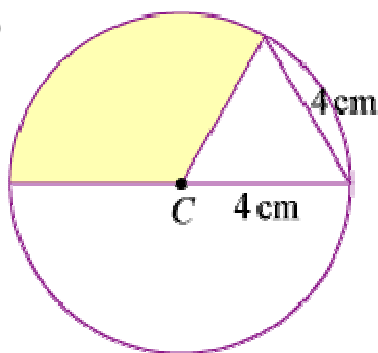

The triangle is equilateral so angle at C in the triangle is $\frac{\pi}{3}$ rad.

Angle subtended at C by shaded sector $= \pi - \frac{\pi}{3}$ rad $= \frac{2\pi}{3}$ rad

Area of shaded sector $= \frac{1}{2} \times 4^2 \times \frac{2\pi}{3} = \frac{16}{3}\pi$ cm²

(f)

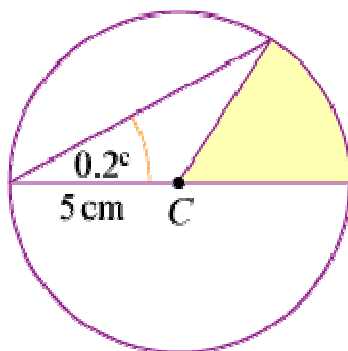

As triangle is isosceles, angle at C in shaded sector is 0.4° .

$$\text{Area of shaded sector} = \frac{1}{2} \times 5^2 \times 0.4 = 5 \text{ cm}^2$$

© Pearson Education Ltd 2008

Solutionbank C2

Edexcel Modular Mathematics for AS and A-Level

Radian measure and its applications

Exercise C, Question 2

Question:

(Note: give non-exact answers to 3 significant figures.)

For the following circles with centre C , the area A of the shaded sector is given. Find the value of x in each case.

(a)

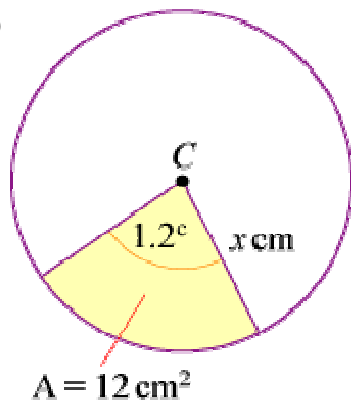

(b)

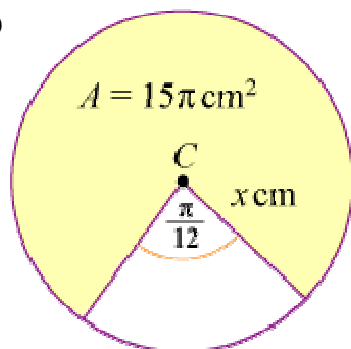

(c)

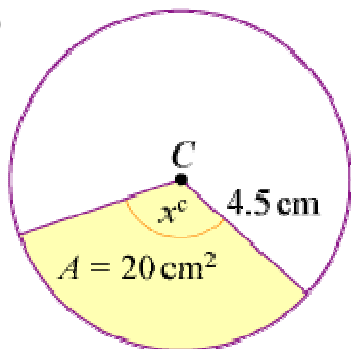

Solution:

(a)

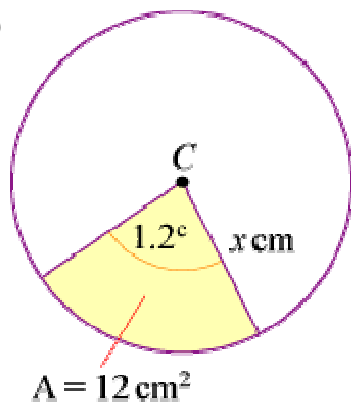

$$\text{Area of shaded sector} = \frac{1}{2} \times x^2 \times 1.2 = 0.6x^2 \text{ cm}^2$$

$$\text{So } 0.6x^2 = 12$$

$$\Rightarrow x^2 = 20$$

$$\Rightarrow x = 4.47 \text{ (3 s.f.)}$$

(b)

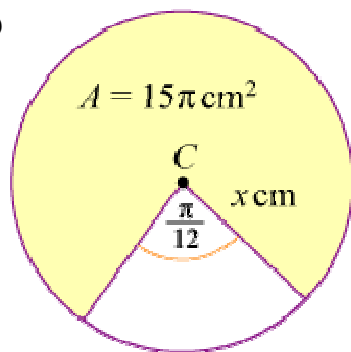

$$\text{Area of shaded sector} = \frac{1}{2} \times x^2 \times \left(2\pi - \frac{\pi}{12} \right) = \frac{1}{2} x^2 \times \frac{23\pi}{12} \text{ cm}^2$$

$$\text{So } 15\pi = \frac{23}{24} \pi x^2$$

$$\Rightarrow x^2 = \frac{24 \times 15}{23}$$

$$\Rightarrow x = 3.96 \text{ (3 s.f.)}$$

(c)

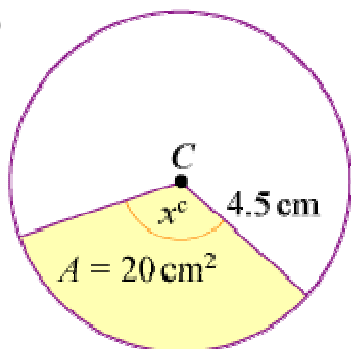

$$\text{Area of shaded sector} = \frac{1}{2} \times 4.5^2 \times x \text{ cm}^2$$

$$\text{So } 20 = \frac{1}{2} \times 4.5^2 x$$

$$\Rightarrow x = \frac{40}{4.5^2} = 1.98 \text{ (3 s.f.)}$$

© Pearson Education Ltd 2008

Solutionbank C2

Edexcel Modular Mathematics for AS and A-Level

Radian measure and its applications

Exercise C, Question 3

Question:

(Note: give non-exact answers to 3 significant figures.)

The arc AB of a circle, centre O and radius 6 cm, has length 4 cm.
Find the area of the minor sector AOB .

Solution:

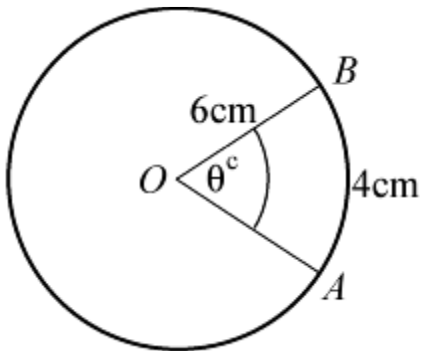

Using $l = r\theta$

$$4 = 6\theta$$

$$\theta = \frac{2}{3}$$

$$\text{So area of sector} = \frac{1}{2} \times 6^2 \times \frac{2}{3} = 12 \text{ cm}^2$$

© Pearson Education Ltd 2008

Solutionbank C2

Edexcel Modular Mathematics for AS and A-Level

Radian measure and its applications

Exercise C, Question 4

Question:

(Note: give non-exact answers to 3 significant figures.)

The chord AB of a circle, centre O and radius 10 cm, has length 18.65 cm and subtends an angle of θ radians at O .

(a) Show that $\theta = 2.40$ (to 3 significant figures).

(b) Find the area of the minor sector AOB .

Solution:

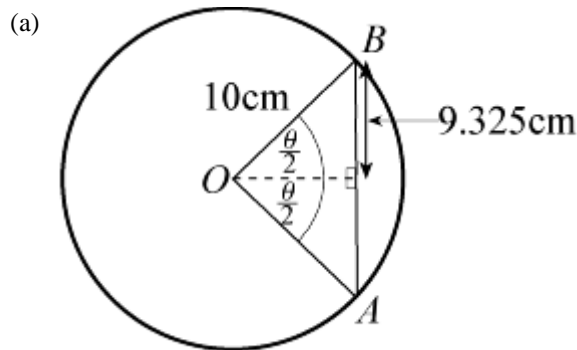

Using the line of symmetry in the isosceles triangle OAB

$$\sin \frac{\theta}{2} = \frac{9.325}{10}$$

$$\frac{\theta}{2} = \sin^{-1} \left(\frac{9.325}{10} \right) \quad (\text{Use radian mode})$$

$$\theta = 2 \sin^{-1} \left(\frac{9.325}{10} \right) = 2.4025 \quad \dots \quad = 2.40 \text{ (3 s.f.)}$$

(b) Area of minor sector $AOB = \frac{1}{2} \times 10^2 \times \theta = 120 \text{ cm}^2$ (3 s.f.)

Solutionbank C2

Edexcel Modular Mathematics for AS and A-Level

Radian measure and its applications

Exercise C, Question 5

Question:

(Note: give non-exact answers to 3 significant figures.)

The area of a sector of a circle of radius 12 cm is 100 cm^2 .
Find the perimeter of the sector.

Solution:

Using area of sector = $\frac{1}{2}r^2\theta$

$$100 = \frac{1}{2} \times 12^2\theta$$

$$\Rightarrow \theta = \frac{100}{72} = \frac{25}{18} \text{ c}$$

$$\text{The perimeter of the sector} = 12 + 12 + 12\theta = 12 \left(2 + \theta \right) = 12 \times \frac{61}{18} = \frac{122}{3} = 40 \frac{2}{3} \text{ cm}$$

© Pearson Education Ltd 2008

Solutionbank C2

Edexcel Modular Mathematics for AS and A-Level

Radian measure and its applications

Exercise C, Question 6

Question:

(Note: give non-exact answers to 3 significant figures.)

The arc AB of a circle, centre O and radius r cm, is such that $\angle AOB = 0.5$ radians. Given that the perimeter of the minor sector AOB is 30 cm:

- Calculate the value of r .
- Show that the area of the minor sector AOB is 36 cm^2 .
- Calculate the area of the segment enclosed by the chord AB and the minor arc AB .

Solution:

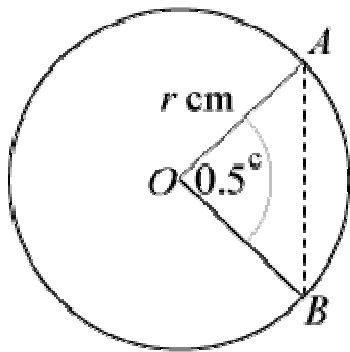

(a) The perimeter of minor sector $AOB = r + r + 0.5r = 2.5r$ cm
So $30 = 2.5r$

$$\Rightarrow r = \frac{30}{2.5} = 12$$

(b) Area of minor sector $= \frac{1}{2} \times r^2 \times \theta = \frac{1}{2} \times 12^2 \times 0.5 = 36 \text{ cm}^2$

(c) Area of segment

$$= \frac{1}{2} r^2 \left(\theta - \sin \theta \right)$$

$$= \frac{1}{2} \times 12^2 \left(0.5 - \sin 0.5 \right)$$

$$= 72 (0.5 - \sin 0.5)$$

$$= 1.48 \text{ cm}^2 \text{ (3 s.f.)}$$

Solutionbank C2

Edexcel Modular Mathematics for AS and A-Level

Radian measure and its applications

Exercise C, Question 7

Question:

(Note: give non-exact answers to 3 significant figures.)

In the diagram, AB is the diameter of a circle of radius r cm and $\angle BOC = \theta$ radians. Given that the area of $\triangle COB$ is equal to that of the shaded segment, show that $\theta + 2 \sin \theta = \pi$.

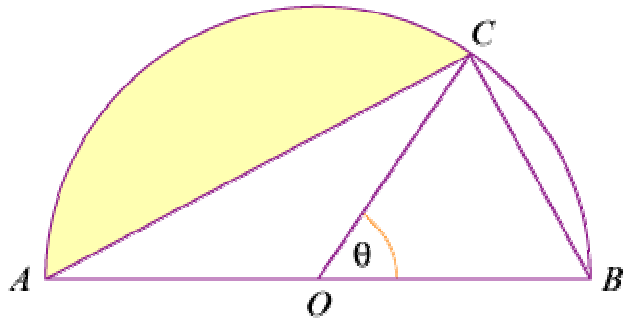

Solution:

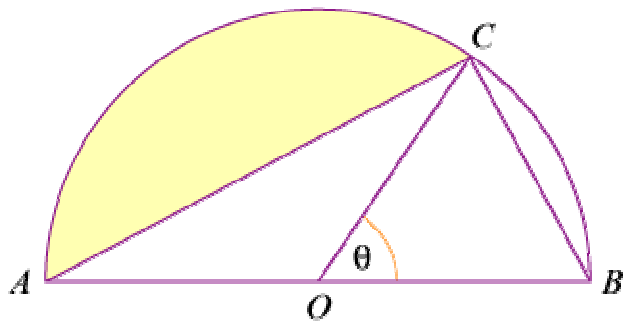

Using the formula

$$\text{area of a triangle} = \frac{1}{2} ab \sin C$$

$$\text{area of } \triangle COB = \frac{1}{2} r^2 \sin \theta \quad \textcircled{1}$$

$$\angle AOC = (\pi - \theta) \text{ rad}$$

$$\text{Area of shaded segment} = \frac{1}{2} r^2 \left[\left(\pi - \theta \right) - \sin \left(\pi - \theta \right) \right] \quad \textcircled{2}$$

As $\textcircled{1}$ and $\textcircled{2}$ are equal

$$\frac{1}{2} r^2 \sin \theta = \frac{1}{2} r^2 \left[\pi - \theta - \sin \left(\pi - \theta \right) \right]$$

$$\sin \theta = \pi - \theta - \sin (\pi - \theta)$$

$$\text{and as } \sin (\pi - \theta) = \sin \theta$$

$$\sin \theta = \pi - \theta - \sin \theta$$

$$\text{So } \theta + 2 \sin \theta = \pi$$

Solutionbank C2

Edexcel Modular Mathematics for AS and A-Level

Radian measure and its applications

Exercise C, Question 8

Question:

(Note: give non-exact answers to 3 significant figures.)

In the diagram, BC is the arc of a circle, centre O and radius 8 cm. The points A and D are such that $OA = OD = 5$ cm. Given that $\angle BOC = 1.6$ radians, calculate the area of the shaded region.

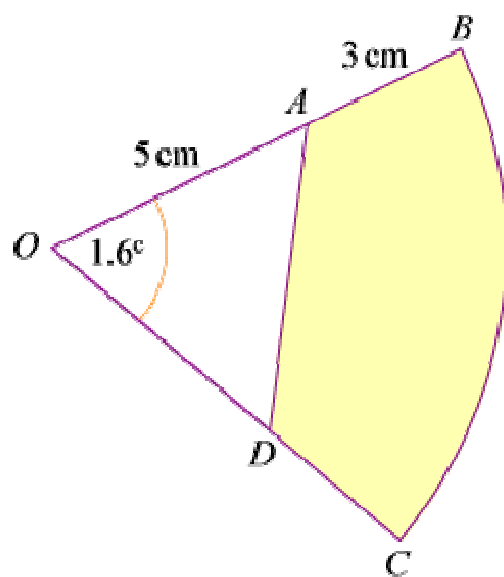

Solution:

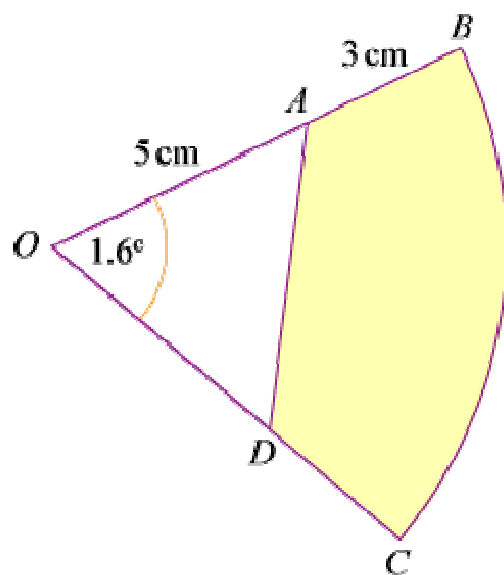

Area of sector OBC = $\frac{1}{2}r^2\theta$ with $r = 8$ cm and $\theta = 1.6$

Area of sector OBC = $\frac{1}{2} \times 8^2 \times 1.6 = 51.2$ cm²

Using area of triangle formula

$$\text{Area of } \triangle OAD = \frac{1}{2} \times 5 \times 5 \times \sin 1.6^\circ = 12.495 \text{ cm}^2$$

$$\text{Area of shaded region} = 51.2 - 12.495 = 38.7 \text{ cm}^2 \text{ (3 s.f.)}$$

© Pearson Education Ltd 2008

Solutionbank C2

Edexcel Modular Mathematics for AS and A-Level

Radian measure and its applications

Exercise C, Question 9

Question:

(Note: give non-exact answers to 3 significant figures.)

In the diagram, AB and AC are tangents to a circle, centre O and radius 3.6 cm. Calculate the area of the shaded region, given that $\angle BOC = \frac{2}{3}\pi$ radians.

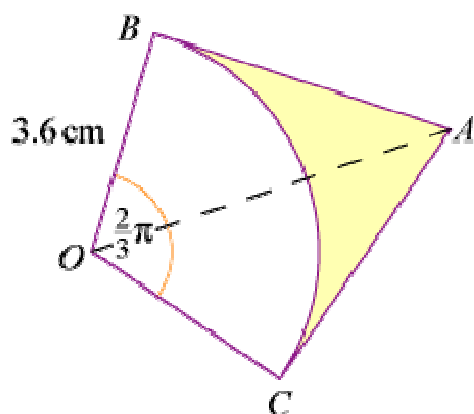

Solution:

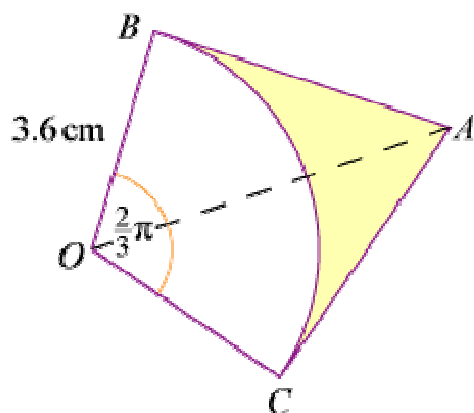

In right-angled $\triangle OBA$: $\tan \frac{\pi}{3} = \frac{AB}{3.6}$

$$\Rightarrow AB = 3.6 \tan \frac{\pi}{3}$$

$$\text{Area of } \triangle OBA = \frac{1}{2} \times 3.6 \times 3.6 \times \tan \frac{\pi}{3}$$

$$\text{So area of quadrilateral } OBAC = 3.6^2 \times \tan \frac{\pi}{3} = 22.447 \dots \text{ cm}^2$$

$$\text{Area of sector} = \frac{1}{2} \times 3.6^2 \times \frac{2}{3}\pi = 13.57 \dots \text{ cm}^2$$

Area of shaded region

$$\begin{aligned} &= \text{area of quadrilateral } OBAC - \text{area of sector } OBC \\ &= 8.88 \text{ cm}^2 \text{ (3 s.f.)} \end{aligned}$$

© Pearson Education Ltd 2008

Solutionbank C2

Edexcel Modular Mathematics for AS and A-Level

Radian measure and its applications

Exercise C, Question 10

Question:

(Note: give non-exact answers to 3 significant figures.)

A chord AB subtends an angle of θ radians at the centre O of a circle of radius 6.5 cm. Find the area of the segment enclosed by the chord AB and the minor arc AB , when:

(a) $\theta = 0.8$

(b) $\theta = \frac{2}{3}\pi$

(c) $\theta = \frac{4}{3}\pi$

Solution:

(a) Area of sector OAB = $\frac{1}{2} \times 6.5^2 \times 0.8$

Area of $\triangle OAB = \frac{1}{2} \times 6.5^2 \times \sin 0.8$

Area of segment = $\frac{1}{2} \times 6.5^2 \times 0.8 - \frac{1}{2} \times 6.5^2 \times \sin 0.8 = 1.75 \text{ cm}^2$ (3 s.f.)

(b) Area of segment = $\frac{1}{2} \times 6.5^2 \left(\frac{2}{3}\pi - \sin \frac{2}{3}\pi \right) = 25.9 \text{ cm}^2$ (3 s.f.)

(c) Area of segment = $\frac{1}{2} \times 6.5^2 \left(\frac{4}{3}\pi - \sin \frac{2}{3}\pi \right) = 25.9 \text{ cm}^2$ (3 s.f.)

Diagram shows why $\frac{2}{3}\pi$ is required.

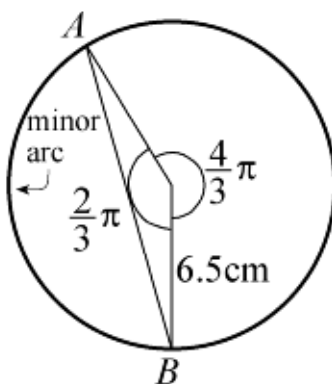

Solutionbank C2

Edexcel Modular Mathematics for AS and A-Level

Radian measure and its applications

Exercise C, Question 11

Question:

(Note: give non-exact answers to 3 significant figures.)

An arc AB subtends an angle of 0.25 radians at the *circumference* of a circle, centre O and radius 6 cm. Calculate the area of the minor sector OAB .

Solution:

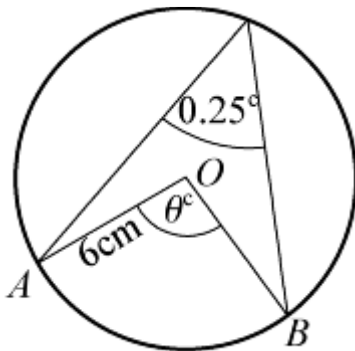

Using the circle theorem: angle at the centre = $2 \times$ angle at circumference
 $\angle AOB = 0.5^\circ$

$$\text{Area of minor sector } AOB = \frac{1}{2} \times 6^2 \times 0.5 = 9 \text{ cm}^2$$

Solutionbank C2

Edexcel Modular Mathematics for AS and A-Level

Radian measure and its applications

Exercise C, Question 12

Question:

(Note: give non-exact answers to 3 significant figures.)

In the diagram, AD and BC are arcs of circles with centre O , such that $OA = OD = r$ cm, $AB = DC = 8$ cm and $\angle BOC = \theta$ radians.

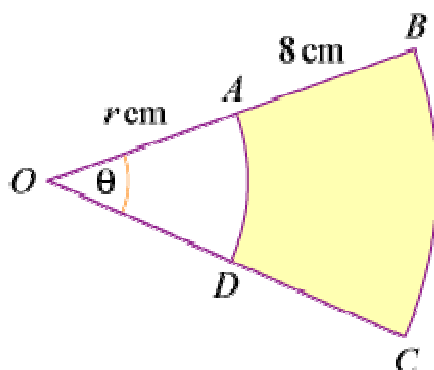

(a) Given that the area of the shaded region is 48 cm^2 , show that

$$r = \frac{6}{\theta} - 4.$$

(b) Given also that $r = 10\theta$, calculate the perimeter of the shaded region.

Solution:

(a)

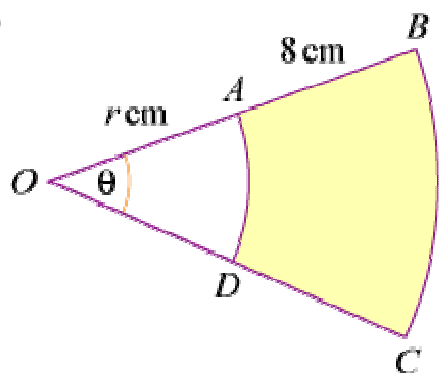

$$\text{Area of larger sector} = \frac{1}{2} (r + 8)^2 \theta \text{ cm}^2$$

$$\text{Area of smaller sector} = \frac{1}{2} r^2 \theta \text{ cm}^2$$

Area of shaded region

$$= \frac{1}{2} (r + 8)^2 \theta - \frac{1}{2} r^2 \theta \text{ cm}^2$$

$$= \frac{1}{2} \theta \left[\left(r^2 + 16r + 64 \right) - r^2 \right] \text{ cm}^2$$

$$= \frac{1}{2}\theta \left(16r + 64 \right) \text{ cm}^2$$

$$= 8\theta (r + 4) \text{ cm}^2$$

$$\text{So } 48 = 8\theta (r + 4)$$

$$\Rightarrow 6 = r\theta + 4\theta \quad *$$

$$\Rightarrow r\theta = 6 - 4\theta$$

$$\Rightarrow r = \frac{6}{\theta} - 4$$

(b) As $r = 10\theta$, using *

$$10\theta^2 + 4\theta - 6 = 0$$

$$5\theta^2 + 2\theta - 3 = 0$$

$$(5\theta - 3)(\theta + 1) = 0$$

$$\text{So } \theta = \frac{3}{5} \text{ and } r = 10\theta = 6$$

$$\text{Perimeter of shaded region} = [r\theta + 8 + (r + 8)\theta + 8] \text{ cm}$$

$$\text{So perimeter} = \frac{18}{5} + 8 + \frac{42}{5} + 8 = 28 \text{ cm}$$

© Pearson Education Ltd 2008

Solutionbank C2

Edexcel Modular Mathematics for AS and A-Level

Radian measure and its applications

Exercise C, Question 13

Question:

(Note: give non-exact answers to 3 significant figures.)

A sector of a circle of radius 28 cm has perimeter P cm and area A cm².
Given that $A = 4P$, find the value of P .

Solution:

$$\text{The area of the sector} = \frac{1}{2} \times 28^2 \times \theta = 392\theta \text{ cm}^2 = A \text{ cm}^2$$

$$\text{The perimeter of the sector} = (28\theta + 56) \text{ cm} = P \text{ cm}$$

$$\text{As } A = 4P$$

$$392\theta = 4(28\theta + 56)$$

$$98\theta = 28\theta + 56$$

$$70\theta = 56$$

$$\theta = \frac{56}{70} = 0.8$$

$$P = 28\theta + 56 = 28(0.8) + 56 = 78.4$$

© Pearson Education Ltd 2008

Solutionbank C2

Edexcel Modular Mathematics for AS and A-Level

Radian measure and its applications

Exercise C, Question 14

Question:

(Note: give non-exact answers to 3 significant figures.)

The diagram shows a triangular plot of land. The sides AB , BC and CA have lengths 12 m, 14 m and 10 m respectively. The lawn is a sector of a circle, centre A and radius 6 m.

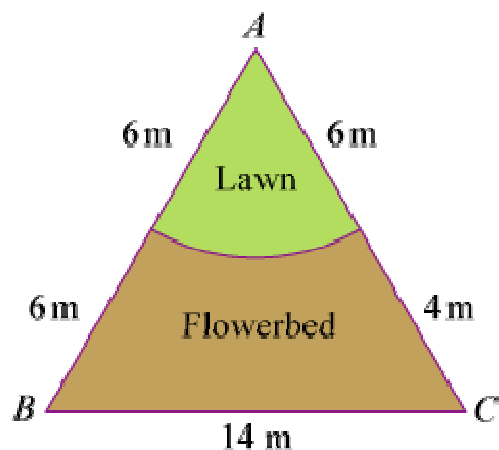

- (a) Show that $\angle BAC = 1.37$ radians, correct to 3 significant figures.
 (b) Calculate the area of the flowerbed.

Solution:

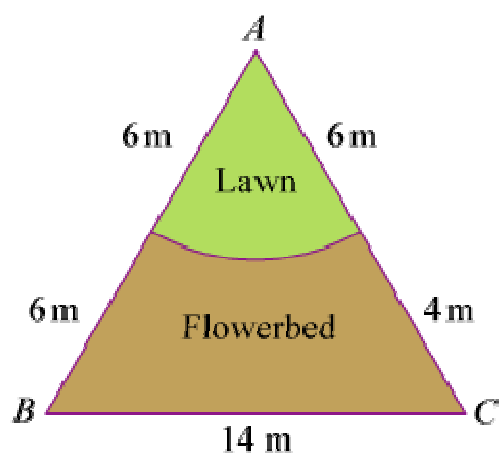

- (a) Using cosine rule

$$\cos A = \frac{b^2 + c^2 - a^2}{2bc}$$

$$\cos A = \frac{10^2 + 12^2 - 14^2}{2 \times 10 \times 12} = 0.2$$

$$A = \cos^{-1} (0.2) \text{ (use in radian mode)}$$

$$A = 1.369 \dots = 1.37 \text{ (3 s.f.)}$$

$$(b) \text{ Area of } \triangle ABC = \frac{1}{2} \times 12 \times 10 \times \sin A = 58.787 \dots \text{ m}^2$$

$$\text{Area of sector (lawn)} = \frac{1}{2} \times 6^2 \times A = 24.649 \dots \text{ m}^2$$

$$\text{Area of flowerbed} = \text{area of } \triangle ABC - \text{area of sector} = 34.1 \text{ m}^2 \text{ (3 s.f.)}$$

© Pearson Education Ltd 2008

Solutionbank C2

Edexcel Modular Mathematics for AS and A-Level

Radian measure and its applications

Exercise D, Question 1

Question:

Triangle ABC is such that $AB = 5$ cm, $AC = 10$ cm and $\angle ABC = 90^\circ$. An arc of a circle, centre A and radius 5 cm, cuts AC at D .

- (a) State, in radians, the value of $\angle BAC$.
- (b) Calculate the area of the region enclosed by BC , DC and the arc BD .

Solution:

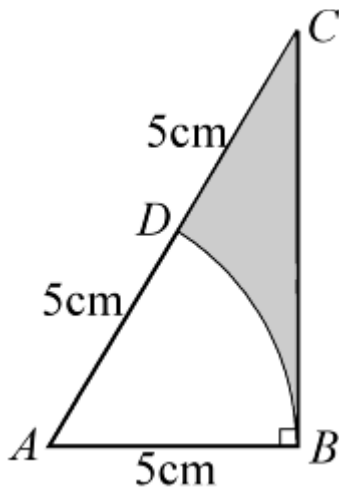

- (a) In the right-angled $\triangle ABC$

$$\cos \angle BAC = \frac{5}{10} = \frac{1}{2}$$

$$\angle BAC = \frac{\pi}{3}$$

(b) Area of $\triangle ABC = \frac{1}{2} \times 5 \times 10 \times \sin \frac{\pi}{3} = 21.650 \dots \text{ cm}^2$

Area of sector $DAB = \frac{1}{2} \times 5^2 \times \frac{\pi}{3} = 13.089 \dots \text{ cm}^2$

Area of shaded region = area of $\triangle ABC$ – area of sector $DAB = 8.56 \text{ cm}^2$ (3 s.f.)

Solutionbank C2

Edexcel Modular Mathematics for AS and A-Level

Radian measure and its applications

Exercise D, Question 2

Question:

The diagram shows a minor sector OMN of a circle centre O and radius r cm. The perimeter of the sector is 100 cm and the area of the sector is A cm².

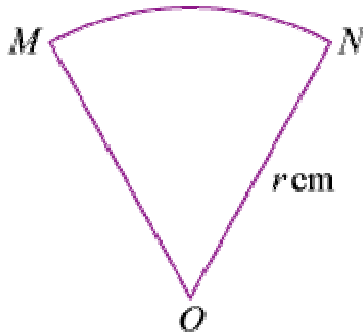

- (a) Show that $A = 50r - r^2$.
- (b) Given that r varies, find:
- The value of r for which A is a maximum and show that A is a maximum.
 - The value of $\angle MON$ for this maximum area.
 - The maximum area of the sector OMN .

[E]

Solution:

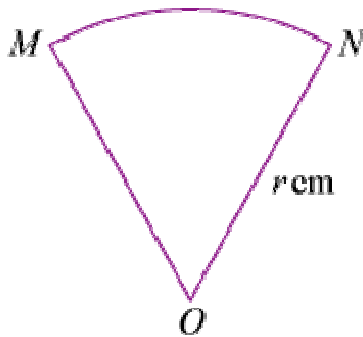

- (a) Let $\angle MON = \theta^\circ$
- Perimeter of sector = $(2r + r\theta)$ cm
- So $100 = 2r + r\theta$
- $$\Rightarrow r\theta = 100 - 2r$$
- $$\Rightarrow \theta = \frac{100}{r} - 2 \text{ *}$$

The area of the sector = A cm² = $\frac{1}{2}r^2\theta$ cm²

$$\text{So } A = \frac{1}{2}r^2 \left(\frac{100}{r} - 2 \right)$$

$$\Rightarrow A = 50r - r^2$$

$$(b) (i) A = - (r^2 - 50r) = - [(r - 25)^2 - 625] = 625 - (r - 25)^2$$

The maximum value occurs when $r = 25$, as for all other values of r something is subtracted from 625.

$$(ii) \text{ Using } *, \text{ when } r = 25, \theta = \frac{100}{25} - 2 = 2^\circ$$

$$(iii) \text{ Maximum area} = 625 \text{ cm}^2$$

© Pearson Education Ltd 2008

Solutionbank C2

Edexcel Modular Mathematics for AS and A-Level

Radian measure and its applications

Exercise D, Question 3

Question:

The diagram shows the triangle OCD with $OC = OD = 17$ cm and $CD = 30$ cm. The mid-point of CD is M . With centre M , a semicircular arc A_1 is drawn on CD as diameter. With centre O and radius 17 cm, a circular arc A_2 is drawn from C to D . The shaded region R is bounded by the arcs A_1 and A_2 . Calculate, giving answers to 2 decimal places:

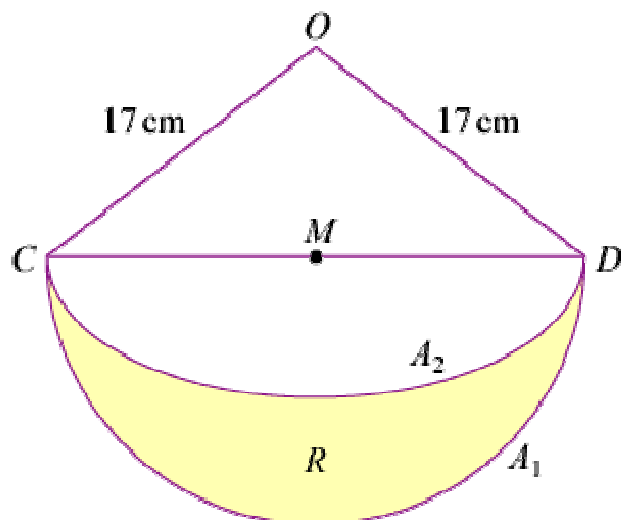

- The area of the triangle OCD .
- The angle COD in radians.
- The area of the shaded region R .

[E]

Solution:

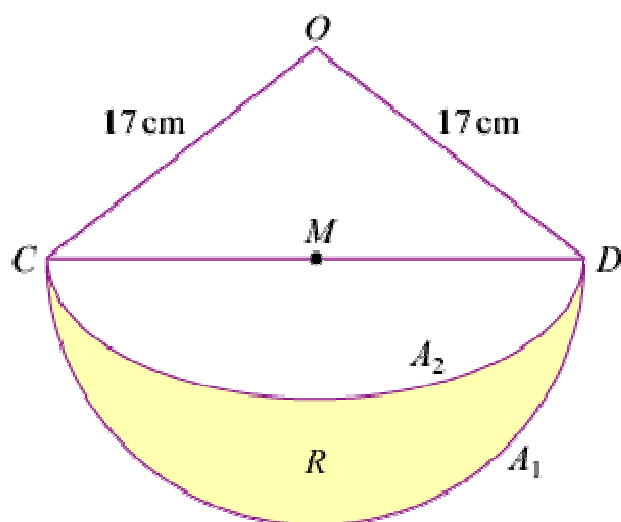

- Using Pythagoras' theorem to find OM :
 $OM^2 = 17^2 - 15^2 = 64$

$$\Rightarrow OM = 8 \text{ cm}$$

$$\text{Area of } \triangle OCD = \frac{1}{2} CD \times OM = \frac{1}{2} \times 30 \times 8 = 120 \text{ cm}^2$$

$$\text{(b) In } \triangle OCM: \sin \angle COM = \frac{15}{17} \Rightarrow \angle COM = 1.0808 \dots^\circ$$

$$\text{So } \angle COD = 2 \times \angle COM = 2.16^\circ \text{ (2 d.p.)}$$

(c) Area of shaded region R = area of semicircle – area of segment CDA_2

Area of segment = area of sector OCD – area of sector $\triangle OCD$

$$= \frac{1}{2} \times 17^2 \left(\angle COD - \sin \angle COD \right) \text{ (angles in radians)}$$

$$= 192.362 \dots \text{ cm}^2 \text{ (use at least 3 d.p.)}$$

$$\text{Area of semicircle} = \frac{1}{2} \times \pi \times 15^2 = 353.429 \dots \text{ cm}^2$$

$$\text{So area of shaded region } R = 353.429 \dots - 192.362 \dots = 161.07 \text{ cm}^2 \text{ (2 d.p.)}$$

Solutionbank C2

Edexcel Modular Mathematics for AS and A-Level

Radian measure and its applications

Exercise D, Question 4

Question:

The diagram shows a circle, centre O , of radius 6 cm. The points A and B are on the circumference of the circle. The area of the shaded major sector is 80 cm^2 . Given that $\angle AOB = \theta$ radians, where $0 < \theta < \pi$, calculate:

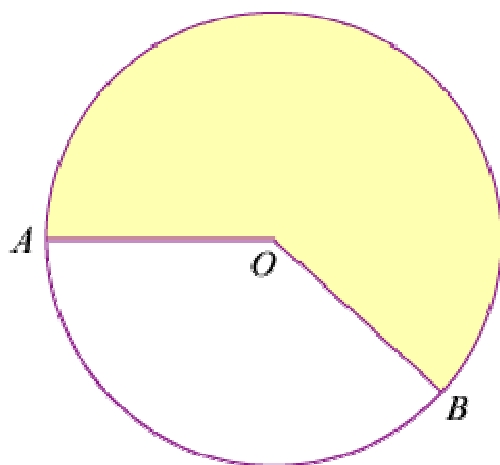

- (a) The value, to 3 decimal places, of θ .
- (b) The length in cm, to 2 decimal places, of the minor arc AB .

[E]

Solution:

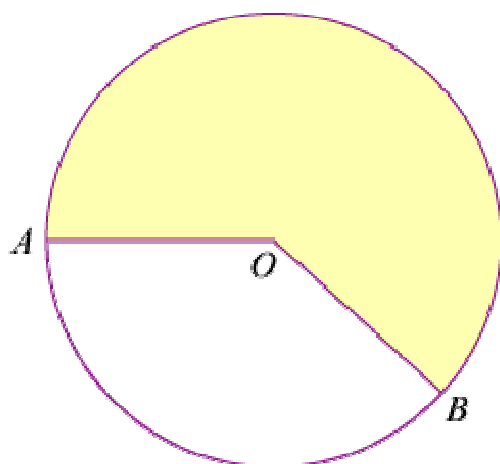

- (a) Reflex angle $AOB = (2\pi - \theta)$ rad

$$\text{Area of shaded sector} = \frac{1}{2} \times 6^2 \times (2\pi - \theta) = 36\pi - 18\theta \text{ cm}^2$$

$$\text{So } 80 = 36\pi - 18\theta$$

$$\Rightarrow 18\theta = 36\pi - 80$$

$$\Rightarrow \theta = \frac{36\pi - 80}{18} = 1.839 \text{ (3 d.p.)}$$

(b) Length of minor arc $AB = 6\theta = 11.03 \text{ cm}$ (2 d.p.)

© Pearson Education Ltd 2008

Solutionbank C2

Edexcel Modular Mathematics for AS and A-Level

Radian measure and its applications

Exercise D, Question 5

Question:

The diagram shows a sector OAB of a circle, centre O and radius r cm. The length of the arc AB is p cm and $\angle AOB$ is θ radians.

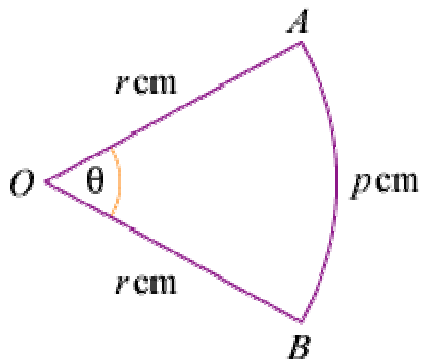

(a) Find θ in terms of p and r .

(b) Deduce that the area of the sector is $\frac{1}{2}pr$ cm².

Given that $r = 4.7$ and $p = 5.3$, where each has been measured to 1 decimal place, find, giving your answer to 3 decimal places:

(c) The least possible value of the area of the sector.

(d) The range of possible values of θ .

[E]

Solution:

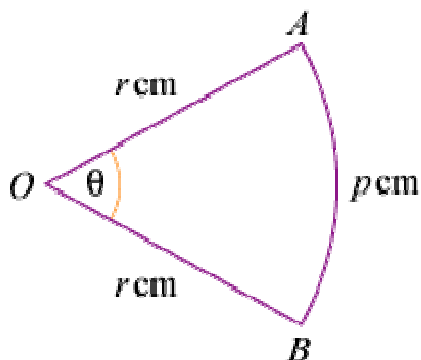

(a) Using $l = r\theta \Rightarrow p = r\theta$

So $\theta = \frac{p}{r}$

(b) Area of sector = $\frac{1}{2}r^2\theta = \frac{1}{2}r^2 \times \frac{p}{r} = \frac{1}{2}pr$ cm²

$$(c) 4.65 \leq r < 4.75, 5.25 \leq p < 5.35$$

$$\text{Least value for area of sector} = \frac{1}{2} \times 5.25 \times 4.65 = 12.207 \text{ cm}^2 \text{ (3 d.p.)}$$

(Note: Lowest is 12.20625, so 12.207 should be given.)

$$(d) \text{ Max value of } \theta = \frac{\max p}{\min r} = \frac{5.35}{4.65} = 1.1505 \dots$$

So give 1.150 (3 d.p.)

$$\text{Min value of } \theta = \frac{\min p}{\max r} = \frac{5.25}{4.75} = 1.10526 \dots$$

So give 1.106 (3 d.p.)

© Pearson Education Ltd 2008

Solutionbank C2

Edexcel Modular Mathematics for AS and A-Level

Radian measure and its applications

Exercise D, Question 6

Question:

The diagram shows a circle centre O and radius 5 cm. The length of the minor arc AB is 6.4 cm.

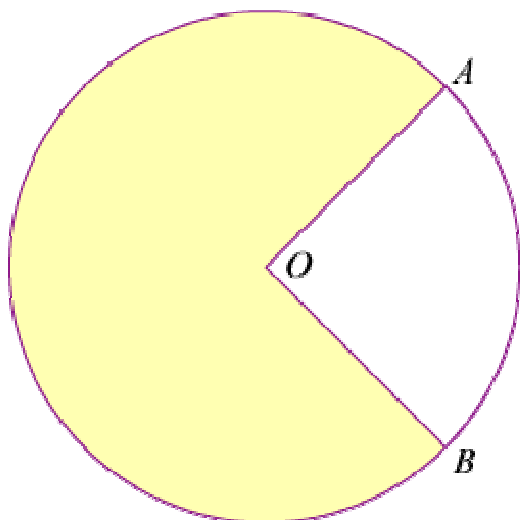

(a) Calculate, in radians, the size of the acute angle AOB .

The area of the minor sector AOB is R_1 cm² and the area of the shaded major sector AOB is R_2 cm².

(b) Calculate the value of R_1 .

(c) Calculate $R_1 : R_2$ in the form $1 : p$, giving the value of p to 3 significant figures.

[E]

Solution:

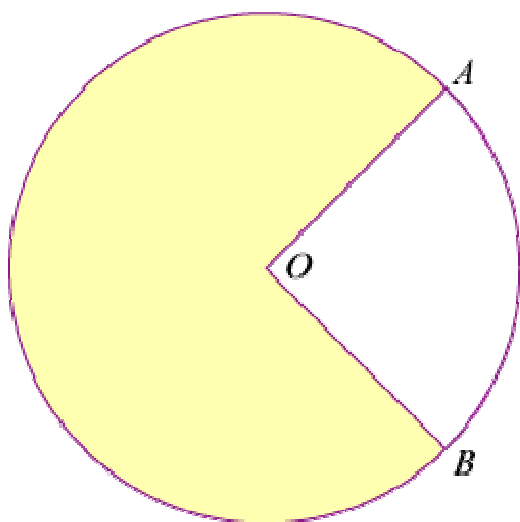

(a) Using $l = r\theta$, $6.4 = 5\theta$

$$\Rightarrow \theta = \frac{6.4}{5} = 1.28^c$$

(b) Using area of sector = $\frac{1}{2}r^2\theta$

$$R_1 = \frac{1}{2} \times 5^2 \times 1.28 = 16$$

(c) $R_2 = \text{area of circle} - R_1 = \pi 5^2 - 16 = 62.5398 \dots$

$$\text{So } \frac{R_1}{R_2} = \frac{16}{62.5398 \dots} = \frac{1}{3.908 \dots} = \frac{1}{p}$$

$$\Rightarrow p = 3.91 \text{ (3 s.f.)}$$

© Pearson Education Ltd 2008

Solutionbank C2

Edexcel Modular Mathematics for AS and A-Level

Radian measure and its applications

Exercise D, Question 7

Question:

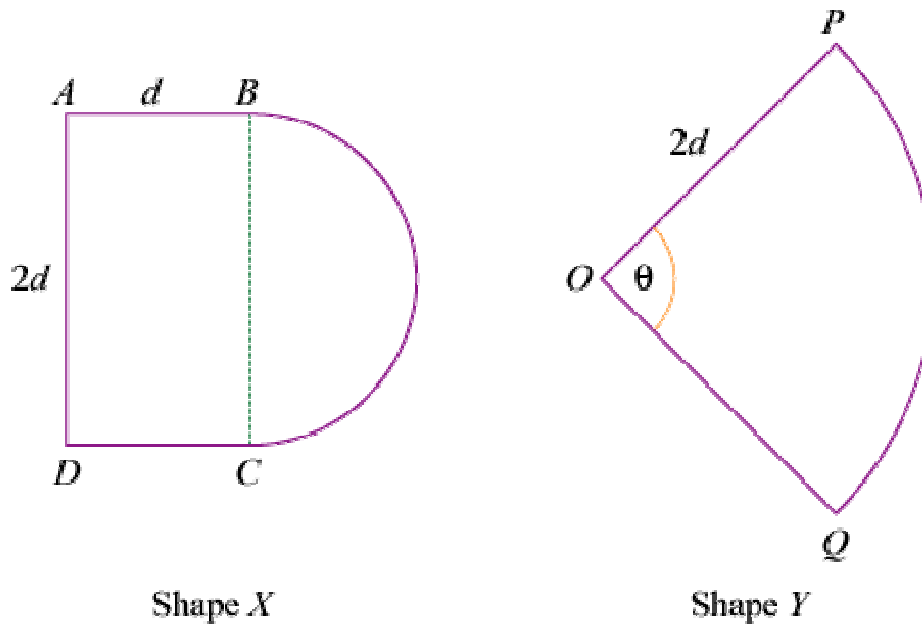

The diagrams show the cross-sections of two drawer handles.

Shape X is a rectangle $ABCD$ joined to a semicircle with BC as diameter. The length $AB = d$ cm and $BC = 2d$ cm. Shape Y is a sector OPQ of a circle with centre O and radius $2d$ cm. Angle POQ is θ radians.

Given that the areas of shapes X and Y are equal:

(a) Prove that $\theta = 1 + \frac{1}{4}\pi$.

Using this value of θ , and given that $d = 3$, find in terms of π :

(b) The perimeter of shape X .

(c) The perimeter of shape Y .

(d) Hence find the difference, in mm, between the perimeters of shapes X and Y . **[E]**

Solution:

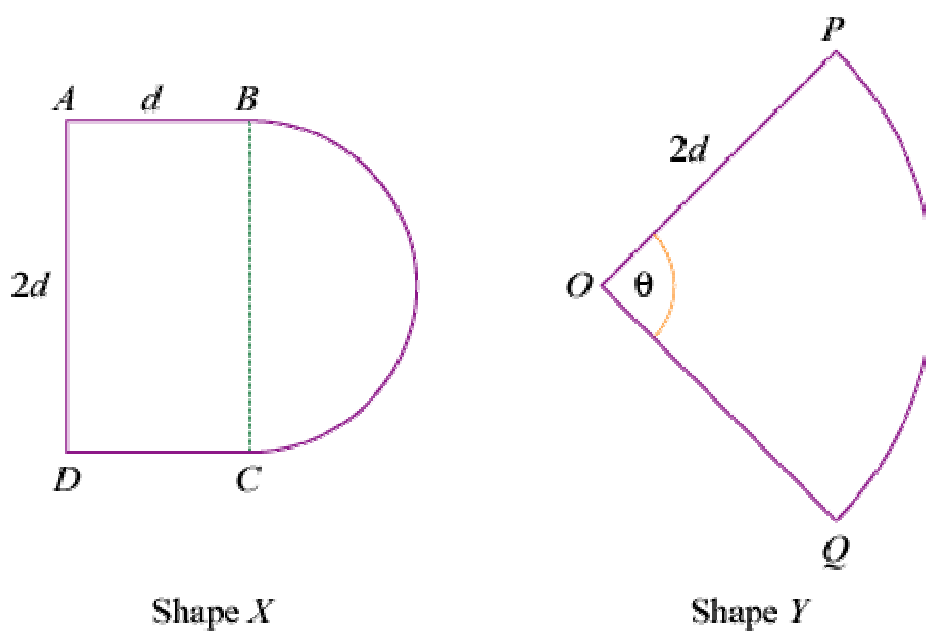

Shape X

Shape Y

(a) Area of shape X
 = area of rectangle + area of semicircle
 = $2d^2 + \frac{1}{2}\pi d^2$ cm²

Area of shape Y = $\frac{1}{2} (2d)^2 \theta = 2d^2 \theta$ cm²

As X = Y: $2d^2 + \frac{1}{2}\pi d^2 = 2d^2 \theta$

Divide by $2d^2$: $1 + \frac{\pi}{4} = \theta$

(b) Perimeter of X
 = $(d + 2d + d + \pi d)$ cm with $d = 3$
 = $(3\pi + 12)$ cm

(c) Perimeter of Y
 = $(2d + 2d + 2d\theta)$ cm with $d = 3$ and $\theta = 1 + \frac{\pi}{4}$
 = $12 + 6 \left(1 + \frac{\pi}{4} \right)$
 = $\left(18 + \frac{3\pi}{2} \right)$ cm

(d) Difference (in mm)
 = $\left[\left(18 + \frac{3\pi}{2} \right) - (3\pi + 12) \right] \times 10$
 = $10 \left(6 - \frac{3\pi}{2} \right)$
 = 12.87 ...
 = 12.9 (3 s.f.)

Solutionbank C2

Edexcel Modular Mathematics for AS and A-Level

Radian measure and its applications

Exercise D, Question 8

Question:

The diagram shows a circle with centre O and radius 6 cm. The chord PQ divides the circle into a minor segment R_1 of area A_1 cm² and a major segment R_2 of area A_2 cm². The chord PQ subtends an angle θ radians at O .

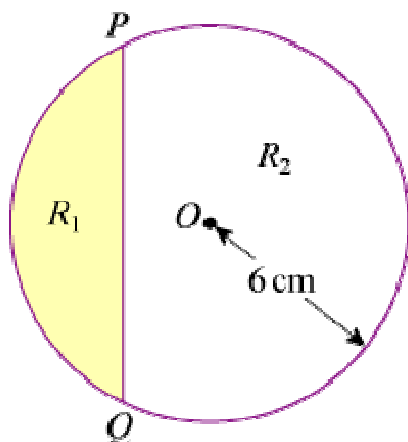

(a) Show that $A_1 = 18 (\theta - \sin \theta)$.

Given that $A_2 = 3A_1$ and $f(\theta) = 2\theta - 2 \sin \theta - \pi$:

(b) Prove that $f(\theta) = 0$.

(c) Evaluate $f(2.3)$ and $f(2.32)$ and deduce that $2.3 < \theta < 2.32$. **[E]**

Solution:

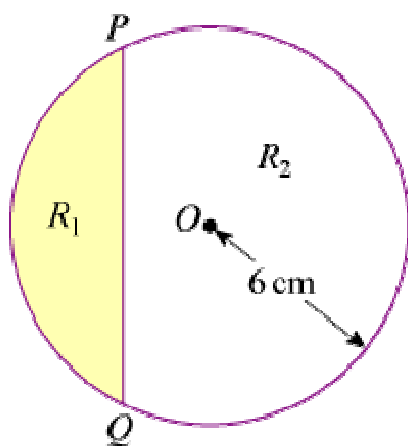

(a) Area of segment R_1 = area of sector OPQ - area of triangle OPQ

$$\Rightarrow A_1 = \frac{1}{2} \times 6^2 \times \theta - \frac{1}{2} \times 6^2 \times \sin \theta$$

$$\Rightarrow A_1 = 18 (\theta - \sin \theta)$$

(b) Area of segment R_2 = area of circle - area of segment R_1

$$\Rightarrow A_2 = \pi 6^2 - 18 (\theta - \sin \theta)$$

$$\Rightarrow A_2 = 36\pi - 18\theta + 18 \sin \theta$$

$$\text{As } A_2 = 3A_1$$

$$36\pi - 18\theta + 18 \sin \theta = 3 (18\theta - 18 \sin \theta) = 54\theta - 54 \sin \theta$$

$$\text{So } 72\theta - 72 \sin \theta - 36\pi = 0$$

$$\Rightarrow 36 (2\theta - 2 \sin \theta - \pi) = 0$$

$$\Rightarrow 2\theta - 2 \sin \theta - \pi = 0$$

$$\text{So } f (\theta) = 0$$

$$\text{(c) } f (2.3) = - 0.0330 \quad \dots$$

$$f (2.32) = + 0.0339 \quad \dots$$

As there is a change of sign θ lies between 2.3 and 2.32.

© Pearson Education Ltd 2008

Solutionbank C2

Edexcel Modular Mathematics for AS and A-Level

Radian measure and its applications

Exercise D, Question 9

Question:

Triangle ABC has $AB = 9$ cm, $BC = 10$ cm and $CA = 5$ cm. A circle, centre A and radius 3 cm, intersects AB and AC at P and Q respectively, as shown in the diagram.

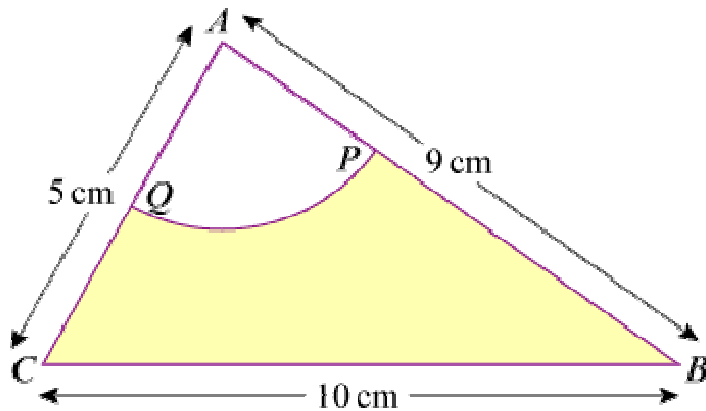

(a) Show that, to 3 decimal places, $\angle BAC = 1.504$ radians.

(b) Calculate:

(i) The area, in cm^2 , of the sector APQ .

(ii) The area, in cm^2 , of the shaded region $BPQC$.

(iii) The perimeter, in cm, of the shaded region $BPQC$. [E]

Solution:

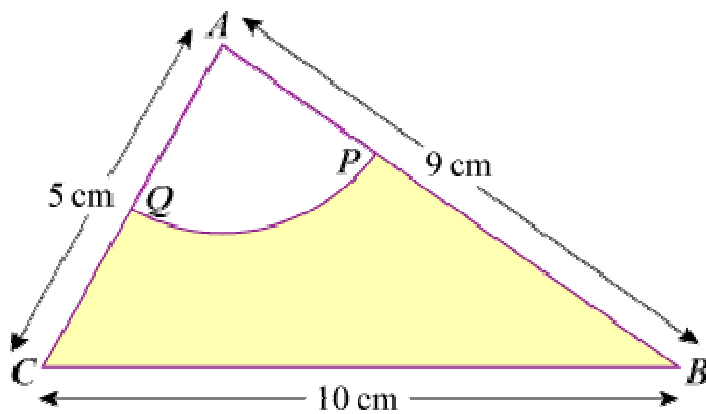

(a) In $\triangle ABC$ using the cosine rule:

$$\cos A = \frac{b^2 + c^2 - a^2}{2bc}$$

$$\Rightarrow \cos \angle BAC = \frac{5^2 + 9^2 - 10^2}{2 \times 5 \times 9} = 0.06$$

$$\Rightarrow \angle BAC = 1.50408 \dots \text{ radians} = 1.504^\circ \text{ (3 d.p.)}$$

(b) (i) Using the sector area formula: area of sector = $\frac{1}{2}r^2\theta$

$$\Rightarrow \text{area of sector APQ} = \frac{1}{2} \times 3^2 \times 1.504 = 6.77 \text{ cm}^2 \text{ (3 s.f.)}$$

(ii) Area of shaded region $BPQC$

= area of $\triangle ABC$ – area of sector APQ

$$= \frac{1}{2} \times 5 \times 9 \times \sin 1.504^\circ - \frac{1}{2} \times 3^2 \times 1.504 \text{ cm}^2$$

$$= 15.681 \dots \text{ cm}^2$$

$$= 15.7 \text{ cm}^2 \text{ (3 s.f.)}$$

(iii) Perimeter of shaded region $BPQC$

= $QC + CB + BP + \text{arc } PQ$

$$= 2 + 10 + 6 + (3 \times 1.504) \text{ cm}$$

$$= 22.51 \dots \text{ cm}$$

$$= 22.5 \text{ cm (3 s.f.)}$$

© Pearson Education Ltd 2008

Solutionbank C2

Edexcel Modular Mathematics for AS and A-Level

Radian measure and its applications

Exercise D, Question 10

Question:

The diagram shows the sector OAB of a circle of radius r cm. The area of the sector is 15 cm^2 and $\angle AOB = 1.5$ radians.

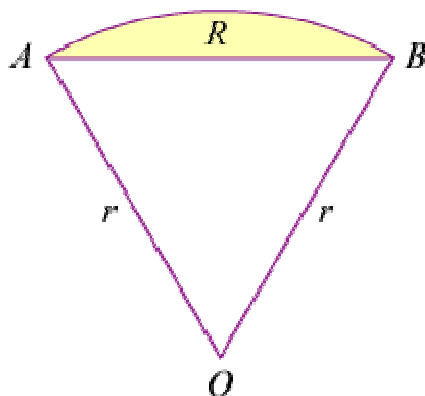

(a) Prove that $r = 2\sqrt{5}$.

(b) Find, in cm, the perimeter of the sector OAB .

The segment R , shaded in the diagram, is enclosed by the arc AB and the straight line AB .

(c) Calculate, to 3 decimal places, the area of R .

[E]

Solution:

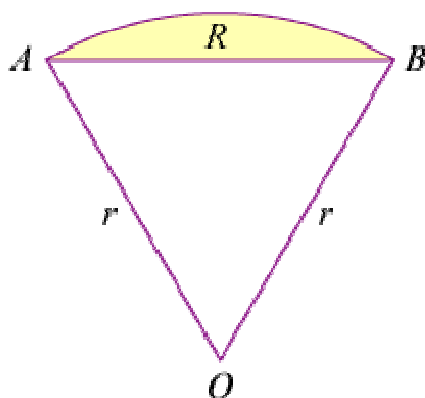

$$(a) \text{ Area of sector} = \frac{1}{2}r^2 \left(1.5 \right) \text{ cm}^2$$

$$\text{So } \frac{3}{4}r^2 = 15$$

$$\Rightarrow r^2 = \frac{60}{3} = 20$$

$$\Rightarrow r = \sqrt{20} = \sqrt{4 \times 5} = \sqrt{4} \times \sqrt{5} = 2\sqrt{5}$$

$$(b) \text{ Arc length } AB = r (1.5) = 3 \sqrt{5} \text{ cm}$$

Perimeter of sector

$$= AO + OB + \text{arc } AB$$

$$= (2 \sqrt{5} + 2 \sqrt{5} + 3 \sqrt{5}) \text{ cm}$$

$$= 7 \sqrt{5} \text{ cm}$$

$$= 15.7 \text{ cm (3 s.f.)}$$

(c) Area of segment R

= area of sector – area of triangle

$$= 15 - \frac{1}{2} r^2 \sin 1.5^\circ \text{ cm}^2$$

$$= (15 - 10 \sin 1.5^\circ) \text{ cm}^2$$

$$= 5.025 \text{ cm}^2 \text{ (3 d.p.)}$$

© Pearson Education Ltd 2008

Solutionbank C2

Edexcel Modular Mathematics for AS and A-Level

Radian measure and its applications

Exercise D, Question 11

Question:

The shape of a badge is a sector ABC of a circle with centre A and radius AB , as shown in the diagram. The triangle ABC is equilateral and has perpendicular height 3 cm.

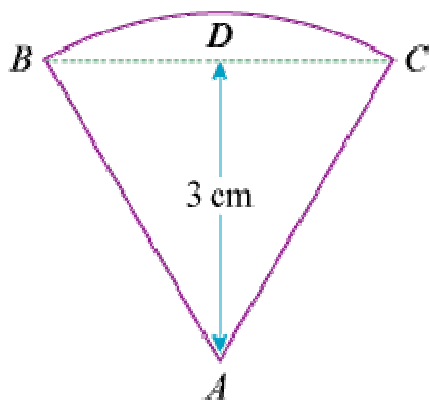

(a) Find, in surd form, the length of AB .

(b) Find, in terms of π , the area of the badge.

(c) Prove that the perimeter of the badge is $\frac{2\sqrt{3}}{3} (\pi + 6)$ cm.

[E]

Solution:

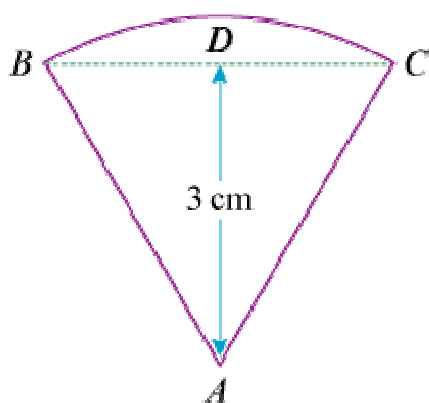

(a) Using the right-angled $\triangle ABD$, with $\angle ABD = 60^\circ$,

$$\sin 60^\circ = \frac{3}{AB}$$

$$\Rightarrow AB = \frac{3}{\sin 60^\circ} = \frac{3}{\frac{\sqrt{3}}{2}} = 3 \times \frac{2}{\sqrt{3}} = 2\sqrt{3} \text{ cm}$$

(b) Area of badge

= area of sector

$$= \frac{1}{2} \times (2\sqrt{3})^2 \theta \text{ where } \theta = \frac{\pi}{3}$$

$$= \frac{1}{2} \times 12 \times \frac{\pi}{3}$$

$$= 2\pi \text{ cm}^2$$

(c) Perimeter of badge

= AB + AC + arc BC

$$= \left(2\sqrt{3} + 2\sqrt{3} + 2\sqrt{3} \frac{\pi}{3} \right) \text{ cm}$$

$$= 2\sqrt{3} \left(2 + \frac{\pi}{3} \right) \text{ cm}$$

$$= \frac{2\sqrt{3}}{3} \left(6 + \pi \right) \text{ cm}$$

© Pearson Education Ltd 2008

Solutionbank C2

Edexcel Modular Mathematics for AS and A-Level

Radian measure and its applications

Exercise D, Question 12

Question:

There is a straight path of length 70 m from the point A to the point B . The points are joined also by a railway track in the form of an arc of the circle whose centre is C and whose radius is 44 m, as shown in the diagram.

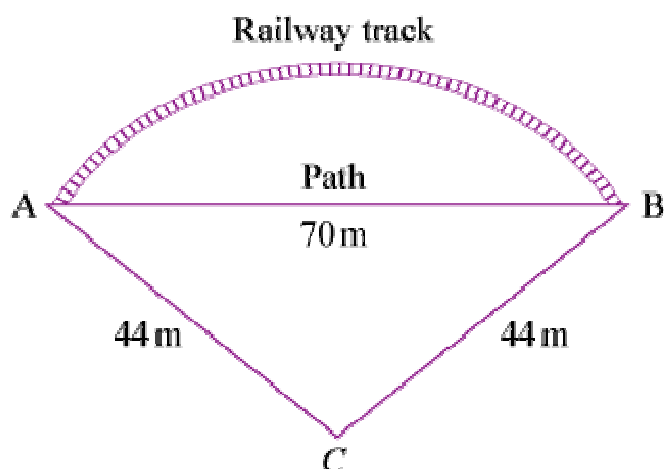

(a) Show that the size, to 2 decimal places, of $\angle ACB$ is 1.84 radians.

(b) Calculate:

- The length of the railway track.
- The shortest distance from C to the path.
- The area of the region bounded by the railway track and the path.

[E]

Solution:

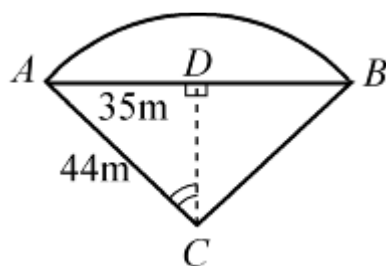

(a) Using right-angled $\triangle ADC$

$$\sin \angle ACD = \frac{35}{44}$$

$$\text{So } \angle ACD = \sin^{-1} \left(\frac{35}{44} \right)$$

$$\text{and } \angle ACB = 2 \sin^{-1} \left(\frac{35}{44} \right) \quad (\text{work in radian mode})$$

$$\Rightarrow \angle ACB = 1.8395 \dots = 1.84^\circ \text{ (2 d.p.)}$$

(b) (i) Length of railway track = length of arc $AB = 44 \times 1.8395 \dots = 80.9 \text{ m}$ (3 s.f.)

(ii) Shortest distance from C to AB is DC .

Using Pythagoras' theorem:

$$DC^2 = 44^2 - 35^2$$

$$DC = \sqrt{44^2 - 35^2} = 26.7 \text{ m}$$
 (3 s.f.)

(iii) Area of region = area of segment

= area of sector ABC - area of $\triangle ABC$

$$= \frac{1}{2} \times 44^2 \times 1.8395 \dots - \frac{1}{2} \times 70 \times DC \quad (\text{or } \frac{1}{2} \times 44^2 \times \sin 1.8395 \dots \text{ } ^\circ)$$

$$= 847 \text{ m}^2 \text{ (3 s.f.)}$$

© Pearson Education Ltd 2008

Solutionbank C2

Edexcel Modular Mathematics for AS and A-Level

Radian measure and its applications

Exercise D, Question 13

Question:

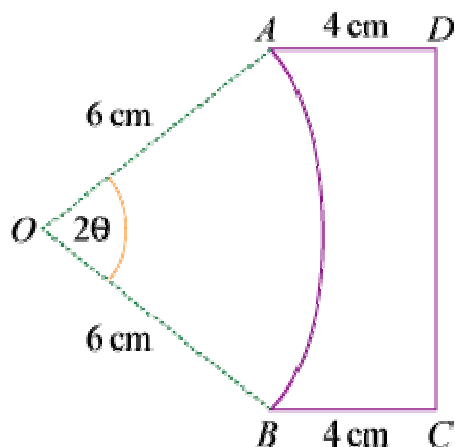

The diagram shows the cross-section $ABCD$ of a glass prism. $AD = BC = 4$ cm and both are at right angles to DC . AB is the arc of a circle, centre O and radius 6 cm. Given that $\angle AOB = 2\theta$ radians, and that the perimeter of the cross-section is $2(7 + \pi)$ cm:

(a) Show that $\left(2\theta + 2 \sin \theta - 1 \right) = \frac{\pi}{3}$.

(b) Verify that $\theta = \frac{\pi}{6}$.

(c) Find the area of the cross-section.

Solution:

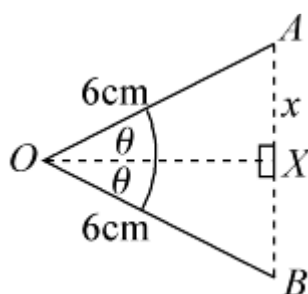

(a) In $\triangle OAX$ (see diagram)

$$\frac{x}{6} = \sin \theta$$

$$\Rightarrow x = 6 \sin \theta$$

So $AB = 2x = 12 \sin \theta$ ($AB = DC$)

The perimeter of cross-section

$$= \text{arc } AB + AD + DC + BC$$

$$= [6(2\theta) + 4 + 12 \sin \theta + 4] \text{ cm}$$

$$= (8 + 12\theta + 12 \sin \theta) \text{ cm}$$

$$\begin{aligned}\text{So } 2(7 + \pi) &= 8 + 12\theta + 12 \sin \theta \\ \Rightarrow 14 + 2\pi &= 8 + 12\theta + 12 \sin \theta \\ \Rightarrow 12\theta + 12 \sin \theta - 6 &= 2\pi\end{aligned}$$

$$\text{Divide by 6: } 2\theta + 2 \sin \theta - 1 = \frac{\pi}{3}$$

$$\text{(b) When } \theta = \frac{\pi}{6}, 2\theta + 2 \sin \theta - 1 = \frac{\pi}{3} + \left(2 \times \frac{1}{2}\right) - 1 = \frac{\pi}{3} \quad \checkmark$$

(c)

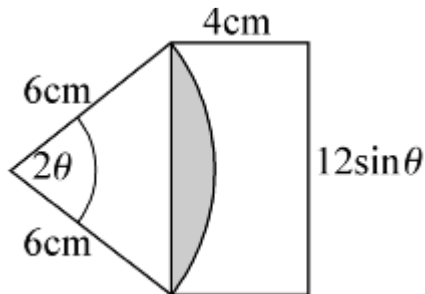

The area of cross-section = area of rectangle $ABCD$ - area of shaded segment

$$\text{Area of rectangle} = 4 \times \left(12 \sin \frac{\pi}{6}\right) = 24 \text{ cm}^2$$

Area of shaded segment

= area of sector - area of triangle

$$= \frac{1}{2} \times 6^2 \times \frac{\pi}{3} - \frac{1}{2} \times 6^2 \sin \frac{\pi}{3}$$

$$= 3.261 \dots \text{ cm}^2$$

So area of cross-section = 20.7 cm^2 (3 s.f.)

Solutionbank C2

Edexcel Modular Mathematics for AS and A-Level

Radian measure and its applications

Exercise D, Question 14

Question:

Two circles C_1 and C_2 , both of radius 12 cm, have centres O_1 and O_2 respectively. O_1 lies on the circumference of C_2 ; O_2 lies on the circumference of C_1 . The circles intersect at A and B , and enclose the region R .

(a) Show that $\angle AO_1B = \frac{2}{3}\pi$ radians.

(b) Hence write down, in terms of π , the perimeter of R .

(c) Find the area of R , giving your answer to 3 significant figures.

Solution:

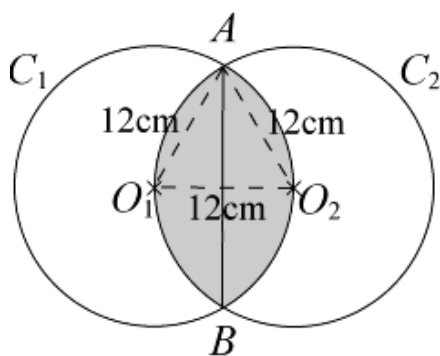

(a) $\triangle AO_1O_2$ is equilateral.

So $\angle AO_1O_2 = \frac{\pi}{3}$ radians

$$\angle AO_1B = 2 \angle AO_1O_2 = \frac{2\pi}{3} \text{ radians}$$

(b) Consider arc AO_2B in circle C_1 .

Using arc length = $r\theta$

$$\text{arc } AO_2B = 12 \times \frac{2\pi}{3} = 8\pi \text{ cm}$$

$$\text{Perimeter of } R = \text{arc } AO_2B + \text{arc } AO_1B = 2 \times 8\pi = 16\pi \text{ cm}$$

(c) Consider the segment AO_2B in circle C_1 .

Area of segment AO_2B

= area of sector O_1AB - area of $\triangle O_1AB$

$$= \frac{1}{2} \times 12^2 \times \frac{2\pi}{3} - \frac{1}{2} \times 12^2 \times \sin \frac{2\pi}{3}$$

$$= 88.442 \dots \text{ cm}^2$$

Area of region R

= area of segment AO_2B + area of segment AO_1B

$$= 2 \times 88.442 \dots \text{ cm}^2$$

$$= 177 \text{ cm}^2 \text{ (3 s.f.)}$$

Solutionbank C2

Edexcel Modular Mathematics for AS and A-Level

Geometric sequences and series

Exercise A, Question 1

Question:

Which of the following are geometric sequences? For the ones that are, give the value of r in the sequence:

(a) 1, 2, 4, 8, 16, 32, ...

(b) 2, 5, 8, 11, 14, ...

(c) 40, 36, 32, 28, ...

(d) 2, 6, 18, 54, 162, ...

(e) 10, 5, 2.5, 1.25, ...

(f) 5, -5, 5, -5, 5, ...

(g) 3, 3, 3, 3, 3, 3, ...

(h) 4, -1, 0.25, -0.0625, ...

Solution:

(a) $1 \xrightarrow{\times 2} 2 \xrightarrow{\times 2} 4 \xrightarrow{\times 2} 8 \xrightarrow{\times 2} 16 \xrightarrow{\times 2} 32$

Geometric $r = 2$

(b) $2 \xrightarrow{+3} 5 \xrightarrow{+3} 8 \xrightarrow{+3} 11 \xrightarrow{+3} 14$

Not geometric (this is an arithmetic sequence)

(c) $40 \xrightarrow{-4} 36 \xrightarrow{-4} 32 \xrightarrow{-4} 28$

Not geometric (arithmetic)

(d) $2 \xrightarrow{\times 3} 6 \xrightarrow{\times 3} 18 \xrightarrow{\times 3} 54$

Geometric $r = 3$

(e) $10 \xrightarrow{\times \frac{1}{2}} 5 \xrightarrow{\times \frac{1}{2}} 2.5 \xrightarrow{\times \frac{1}{2}} 1.25$

Geometric $r = \frac{1}{2}$

$$(f) \begin{array}{ccccccc} 5 & & -5 & & 5 & & -5 \\ \downarrow & & \downarrow & & \downarrow & & \downarrow \\ \times -1 & & \times -1 & & \times -1 & & \end{array}$$

Geometric $r = -1$

$$(g) \begin{array}{ccccccc} 3 & & 3 & & 3 & & 3 \\ \downarrow & & \downarrow & & \downarrow & & \downarrow \\ \times 1 & & \times 1 & & \times 1 & & \times 1 \end{array}$$

Geometric $r = 1$

$$(h) \begin{array}{ccccccc} 4 & & -1 & & 0.25 & & -0.0625 \\ \downarrow & & \downarrow & & \downarrow & & \downarrow \\ \times \frac{-1}{4} & & \times \frac{-1}{4} & & \times \frac{-1}{4} & & \end{array}$$

Geometric $r = -\frac{1}{4}$

© Pearson Education Ltd 2008

Solutionbank C2

Edexcel Modular Mathematics for AS and A-Level

Geometric sequences and series

Exercise A, Question 2

Question:

Continue the following geometric sequences for three more terms:

(a) 5, 15, 45, ...

(b) 4, -8, 16, ...

(c) 60, 30, 15, ...

(d) $1, \frac{1}{4}, \frac{1}{16}, \dots$

(e) $1, p, p^2, \dots$

(f) $x, -2x^2, 4x^3, \dots$

Solution:

(a) $5 \xrightarrow{\times 3} 15 \xrightarrow{\times 3} 45 \xrightarrow{\times 3} 135 \xrightarrow{\times 3} 405 \xrightarrow{\times 3} 1215$

(b) $4 \xrightarrow{\times -2} -8 \xrightarrow{\times -2} 16 \xrightarrow{\times -2} -32 \xrightarrow{\times -2} 64 \xrightarrow{\times -2} -128$

(c) $60 \xrightarrow{\times \frac{1}{2}} 30 \xrightarrow{\times \frac{1}{2}} 15 \xrightarrow{\times \frac{1}{2}} 7.5 \xrightarrow{\times \frac{1}{2}} 3.75 \xrightarrow{\times \frac{1}{2}} 1.875$

(d) $1 \xrightarrow{\times \frac{1}{4}} \frac{1}{4} \xrightarrow{\times \frac{1}{4}} \frac{1}{16} \xrightarrow{\times \frac{1}{4}} \frac{1}{64} \xrightarrow{\times \frac{1}{4}} \frac{1}{256} \xrightarrow{\times \frac{1}{4}} \frac{1}{1024}$

(e) $1 \xrightarrow{\times p} p \xrightarrow{\times p} p^2 \xrightarrow{\times p} p^3 \xrightarrow{\times p} p^4 \xrightarrow{\times p} p^5$

(f) $x \xrightarrow{\times -2x} -2x^2 \xrightarrow{\times -2x} 4x^3 \xrightarrow{\times -2x} -8x^4 \xrightarrow{\times -2x} 16x^5 \xrightarrow{\times -2x} -32x^6$

Solutionbank C2

Edexcel Modular Mathematics for AS and A-Level

Geometric sequences and series

Exercise A, Question 3

Question:

If 3, x and 9 are the first three terms of a geometric sequence. Find:

- (a) The exact value of x .
- (b) The exact value of the 4th term.

Solution:

(a) 3 x 9

$$\text{Common ratio} = \frac{\text{term 2}}{\text{term 1}} \text{ or } \frac{\text{term 3}}{\text{term 2}} = \frac{x}{3} \text{ or } \frac{9}{x}$$

Therefore,

$$\frac{x}{3} = \frac{9}{x} \text{ (cross multiply)}$$

$$x^2 = 27 \quad (\sqrt{\quad})$$

$$x = \sqrt{27}$$

$$x = \sqrt{9 \times 3}$$

$$x = 3\sqrt{3}$$

(b) Term 4 = term 3 $\times r$

$$\text{Term 3} = 9 \text{ and } r = \frac{\text{term 2}}{\text{term 1}} = \frac{3\sqrt{3}}{3} = \sqrt{3}$$

$$\text{So term 4} = 9\sqrt{3}$$

Solutionbank C2

Edexcel Modular Mathematics for AS and A-Level

Geometric sequences and series

Exercise B, Question 1

Question:

Find the sixth, tenth and n th terms of the following geometric sequences:

(a) 2, 6, 18, 54, ...

(b) 100, 50, 25, 12.5, ...

(c) 1, -2, 4, -8, ...

(d) 1, 1.1, 1.21, 1.331, ...

Solution:

(a)
$$\begin{array}{cccc} 2 & 6 & 18 & 54 \\ \downarrow & \downarrow & \downarrow & \\ \times 3 & \times 3 & \times 3 & \end{array}$$

In this series $a = 2$ and $r = 3$

$$6\text{th term} = ar^{6-1} = ar^5 = 2 \times 3^5 = 486$$

$$10\text{th term} = ar^{10-1} = ar^9 = 2 \times 3^9 = 39366$$

$$n\text{th term} = ar^{n-1} = 2 \times 3^{n-1}$$

(b)
$$\begin{array}{cccc} 100 & 50 & 25 & 12.5 \\ \downarrow & \downarrow & \downarrow & \\ \times \frac{1}{2} & \times \frac{1}{2} & \times \frac{1}{2} & \end{array}$$

In this series $a = 100$, $r = \frac{1}{2}$

$$6\text{th term} = ar^{6-1} = ar^5 = 100 \times \left(\frac{1}{2}\right)^5 = \frac{25}{8}$$

$$10\text{th term} = ar^{10-1} = ar^9 = 100 \times \left(\frac{1}{2}\right)^9 = \frac{25}{128}$$

$$n\text{th term} = ar^{n-1} = 100 \times \left(\frac{1}{2}\right)^{n-1} = \frac{4 \times 25}{2^{n-1}} = \frac{25}{2^{n-3}}$$

(c)
$$\begin{array}{cccc} 1 & -2 & 4 & -8 \\ \downarrow & \downarrow & \downarrow & \\ \times -2 & \times -2 & \times -2 & \end{array}$$

In this series $a = 1$ and $r = -2$

$$6\text{th term} = ar^{6-1} = ar^5 = 1 \times (-2)^5 = -32$$

$$10\text{th term} = ar^{10-1} = ar^9 = 1 \times (-2)^9 = -512$$

$$n\text{th term} = ar^{n-1} = 1 \times (-2)^{n-1} = (-2)^{n-1}$$

(d)
$$\begin{array}{cccc} 1 & 1.1 & 1.21 & 1.331 \\ \downarrow & \downarrow & \downarrow & \\ \times 1.1 & \times 1.1 & \times 1.1 & \end{array}$$

In this series $a = 1$ and $r = 1.1$

$$\text{6th term is } ar^{6-1} = ar^5 = 1 \times (1.1)^5 = 1.61051$$

$$\text{10th term is } ar^{10-1} = ar^9 = 1 \times (1.1)^9 = 2.35795 \text{ (5 d.p.)}$$

$$\text{nth term is } ar^{n-1} = 1 \times (1.1)^{n-1} = (1.1)^{n-1}$$

© Pearson Education Ltd 2008

Solutionbank C2

Edexcel Modular Mathematics for AS and A-Level

Geometric sequences and series

Exercise B, Question 2

Question:

The n th term of a geometric sequence is $2 \times (5)^n$. Find the first and 5th terms.

Solution:

$$n\text{th term} = 2 \times (5)^n$$

$$\text{1st term } (n = 1) = 2 \times 5^1 = 10$$

$$\text{5th term } (n = 5) = 2 \times 5^5 = 2 \times 3125 = 6250$$

© Pearson Education Ltd 2008

Solutionbank C2

Edexcel Modular Mathematics for AS and A-Level

Geometric sequences and series

Exercise B, Question 3

Question:

The sixth term of a geometric sequence is 32 and the 3rd term is 4. Find the first term and the common ratio.

Solution:

Let the first term = a and common ratio = r

6th term is 32

$$\Rightarrow ar^{6-1} = 32$$

$$\Rightarrow ar^5 = 32 \quad \textcircled{1}$$

3rd term is 4

$$\Rightarrow ar^{3-1} = 4$$

$$\Rightarrow ar^2 = 4 \quad \textcircled{2}$$

$\textcircled{1} \div \textcircled{2}$:

$$\frac{ar^5}{ar^2} = \frac{32}{4}$$

$$r^3 = 8$$

$$r = 2$$

Common ratio is 2

Substitute $r = 2$ into equation $\textcircled{2}$

$$a \times 2^2 = 4$$

$$a \times 4 = 4 \quad (\div 4)$$

$$a = 1$$

First term is 1

Solutionbank C2

Edexcel Modular Mathematics for AS and A-Level

Geometric sequences and series

Exercise B, Question 4

Question:

Given that the first term of a geometric sequence is 4, and the third is 1, find possible values for the 6th term.

Solution:

$$\text{First term is } 4 \Rightarrow a = 4 \quad \textcircled{1}$$

$$\text{Third term is } 1 \Rightarrow ar^{3-1} = 1 \Rightarrow ar^2 = 1 \quad \textcircled{2}$$

Substitute $a = 4$ into $\textcircled{2}$

$$4r^2 = 1 \quad (\div 4)$$

$$r^2 = \frac{1}{4} \quad \left(\sqrt{\quad} \right)$$

$$r = \pm \frac{1}{2}$$

$$\text{The sixth term} = ar^{6-1} = ar^5$$

$$\text{If } r = \frac{1}{2} \text{ then sixth term} = 4 \times \left(\frac{1}{2} \right)^5 = \frac{1}{8}$$

$$\text{If } r = -\frac{1}{2} \text{ then sixth term} = 4 \times \left(-\frac{1}{2} \right)^5 = -\frac{1}{8}$$

Possible values for sixth term are $\frac{1}{8}$ and $-\frac{1}{8}$.

Solutionbank C2

Edexcel Modular Mathematics for AS and A-Level

Geometric sequences and series

Exercise B, Question 5

Question:

The expressions $x - 6$, $2x$ and x^2 form the first three terms of a geometric progression. By calculating two different expressions for the common ratio, form and solve an equation in x to find possible values of the first term.

Solution:

If $x - 6$, $2x$ and x^2 are terms in a geometric progression then

$$\frac{2x}{x-6} = \frac{x^2}{2x} \quad (\text{cancel first})$$

$$\frac{2x}{x-6} = \frac{x}{2} \quad (\text{cross multiply})$$

$$4x = x(x - 6)$$

$$4x = x^2 - 6x$$

$$0 = x^2 - 10x$$

$$0 = x(x - 10)$$

$$x = 0 \text{ or } 10$$

$$\text{If } x = 0 \text{ then first term} = 0 - 6 = -6$$

$$\text{If } x = 10 \text{ then first term} = 10 - 6 = 4$$

Solutionbank C2

Edexcel Modular Mathematics for AS and A-Level

Geometric sequences and series

Exercise C, Question 1

Question:

A population of ants is growing at a rate of 10% a year. If there were 200 ants in the initial population, write down the number after

- (a) 1 year,
- (b) 2 years,
- (c) 3 years and
- (d) 10 years.

Solution:

A growth of 10% a year gives a multiplication factor of 1.1.

- (a) After 1 year number is $200 \times 1.1 = 220$
- (b) After 2 years number is $200 \times 1.1^2 = 242$
- (c) After 3 years number is
 $200 \times 1.1^3 = 266.2 = 266$ (to nearest whole number)
- (d) After 10 years number is
 $200 \times 1.1^{10} = 518.748 \dots = 519$ (to nearest whole number)

Solutionbank C2

Edexcel Modular Mathematics for AS and A-Level

Geometric sequences and series

Exercise C, Question 2

Question:

A motorcycle has four gears. The maximum speed in bottom gear is 40 km h^{-1} and the maximum speed in top gear is 120 km h^{-1} . Given that the maximum speeds in each successive gear form a geometric progression, calculate, in km h^{-1} to one decimal place, the maximum speeds in the two intermediate gears.

[E]

Solution:

Let maximum speed in bottom gear be $a \text{ km h}^{-1}$

This gives maximum speeds in each successive gear to be

$$a \quad ar^2 \quad ar^3$$

Where r is the common ratio.

We are given

$$a = 40 \text{ ①}$$

$$ar^3 = 120 \text{ ②}$$

Substitute ① into ②:

$$40r^3 = 120 \quad (\div 40)$$

$$r^3 = 3$$

$$r = \sqrt[3]{3}$$

$$r = 1.442 \quad \dots \quad (3 \text{ d.p.})$$

Maximum speed in 2nd gear is

$$ar = 40 \times 1.442 \quad \dots \quad = 57.7 \text{ km h}^{-1}$$

Maximum speed in 3rd gear is

$$ar^2 = 40 \times (1.442 \quad \dots \quad)^2 = 83.2 \text{ km h}^{-1}$$

Solutionbank C2

Edexcel Modular Mathematics for AS and A-Level

Geometric sequences and series

Exercise C, Question 3

Question:

A car depreciates in value by 15% a year. If it is worth £11 054.25 after 3 years, what was its new price and when will it first be worth less than £5000?

Solution:

Let the car be worth £A when new.

If it depreciates by 15% each year the multiplication factor is 0.85 for every year.

We are given

price after 3 years is £11 054.25

$$\Rightarrow A \times (0.85)^3 = 11\,054.25$$

$$\Rightarrow A = \frac{11\,054.25}{(0.85)^3} = 18\,000$$

Its new price is £18 000

If its value is less than £5000

$$18\,000 \times (0.85)^n < 5000$$

$$(0.85)^n < \frac{5000}{18\,000}$$

$$\log (0.85)^n < \log \left(\frac{5000}{18\,000} \right)$$

$$n \log (0.85) < \log \left(\frac{5000}{18\,000} \right)$$

$$n > \frac{\log \left(\frac{5000}{18\,000} \right)}{\log (0.85)}$$

Note: < changes to > because $\log(0.85)$ is negative.

So $n > 7.88$

n must be an integer.

So number of years is 8.

It is often easier to solve these problems using an equality rather than an inequality.

E.g. solve $18\,000 \times (0.85)^n = 5000$

Solutionbank C2

Edexcel Modular Mathematics for AS and A-Level

Geometric sequences and series

Exercise C, Question 4

Question:

The population decline in a school of whales can be modelled by a geometric progression. Initially there were 80 whales in the school. Four years later there were 40. Find out how many there will be at the end of the fifth year. (Round to the nearest whole number.)

Solution:

Let the common ratio be r —the multiplication factor.

Initially there are 80 whales

After 1 year there is $80r$

After 2 years there will be $80r^2$

After 3 years there will be $80r^3$

After 4 years there will be $80r^4$

We are told this number is 40

$$80r^4 = 40 \quad (\div 80)$$

$$r^4 = \frac{40}{80}$$

$$r^4 = \frac{1}{2}$$

$$r = \sqrt[4]{\frac{1}{2}}$$

$$r = 0.840896 \quad \dots$$

After 5 years there will be

$$40 \times 0.840896 \quad \dots = 33.635 \quad \dots = 34 \text{ whales}$$

Solutionbank C2

Edexcel Modular Mathematics for AS and A-Level

Geometric sequences and series

Exercise C, Question 5

Question:

Find which term in the progression 3, 12, 48, ... is the first to exceed 1 000 000.

Solution:

$$3 \quad 12 \quad 48 \quad \dots$$

This is a geometric series with $a = 3$ and $r = 4$.

If the term exceeds 1 000 000 then

$$ar^{n-1} > 1\,000\,000$$

Substitute $a = 3$, $r = 4$

$$3 \times 4^{n-1} > 1\,000\,000$$

$$4^{n-1} > \frac{1\,000\,000}{3}$$

$$\log 4^{n-1} > \log \left(\frac{1\,000\,000}{3} \right)$$

$$(n-1) \log 4 > \log \left(\frac{1\,000\,000}{3} \right)$$

$$(n-1) > \frac{\log \left(\frac{1\,000\,000}{3} \right)}{\log 4}$$

$$n-1 > 9.173 \quad \dots$$

$$n > 10.173 \quad \dots$$

So $n = 11$

Solutionbank C2

Edexcel Modular Mathematics for AS and A-Level

Geometric sequences and series

Exercise C, Question 6

Question:

A virus is spreading such that the number of people infected increases by 4% a day. Initially 100 people were diagnosed with the virus. How many days will it be before 1000 are infected?

Solution:

If the number of people infected increases by 4% the multiplication factor is 1.04.

After n days $100 \times (1.04)^n$ people will be infected.

If 1000 people are infected

$$100 \times (1.04)^n = 1000$$

$$(1.04)^n = 10$$

$$\log (1.04)^n = \log 10$$

$$n \log (1.04) = 1$$

$$n = \frac{1}{\log (1.04)}$$

$$n = 58.708 \dots$$

It would take 59 days.

Solutionbank C2

Edexcel Modular Mathematics for AS and A-Level

Geometric sequences and series

Exercise C, Question 7

Question:

I invest £ A in the bank at a rate of interest of 3.5% per annum. How long will it be before I double my money?

Solution:

If the increase is 3.5% per annum the multiplication factor is 1.035.

Therefore after n years I will have £ $A \times (1.035)^n$

If the money is doubled it will equal $2A$, therefore

$$A \times (1.035)^n = 2A$$

$$(1.035)^n = 2$$

$$\log (1.035)^n = \log 2$$

$$n \log (1.035) = \log 2$$

$$n = \frac{\log 2}{\log (1.035)} = 20.14879 \dots$$

My money will double after 20.15 years.

Solutionbank C2

Edexcel Modular Mathematics for AS and A-Level

Geometric sequences and series

Exercise C, Question 8

Question:

The fish in a particular area of the North Sea are being reduced by 6% each year due to overfishing. How long would it be before the fish stocks are halved?

Solution:

The reduction is 6% which gives a multiplication factor of 0.94.

Let the number of fish now be F .

After n years there will be $F \times (0.94)^n$

When their number is halved the number will be $\frac{1}{2}F$

Set these equal to each other:

$$F \times (0.94)^n = \frac{1}{2}F$$

$$(0.94)^n = \frac{1}{2}$$

$$\log (0.94)^n = \log \left(\frac{1}{2} \right)$$

$$n \log (0.94) = \log \left(\frac{1}{2} \right)$$

$$n = \frac{\log \left(\frac{1}{2} \right)}{\log (0.94)}$$

$$n = 11.2$$

The fish stocks will half in 11.2 years.

Solutionbank C2

Edexcel Modular Mathematics for AS and A-Level

Geometric sequences and series

Exercise D, Question 1

Question:

Find the sum of the following geometric series (to 3 d.p. if necessary):

(a) $1 + 2 + 4 + 8 + \dots$ (8 terms)

(b) $32 + 16 + 8 + \dots$ (10 terms)

(c) $4 - 12 + 36 - 108 \dots$ (6 terms)

(d) $729 - 243 + 81 - \dots - \frac{1}{3}$

(e) $\sum_{r=1}^6 4^r$

(f) $\sum_{r=1}^8 2 \times (3)^r$

(g) $\sum_{r=1}^{10} 6 \times \left(\frac{1}{2}\right)^r$

(h) $\sum_{r=0}^5 60 \times \left(-\frac{1}{3}\right)^r$

Solution:

(a) $1 + 2 + 4 + 8 + \dots$ (8 terms)

In this series $a = 1, r = 2, n = 8$.

As $|r| > 1$ use $S_n = \frac{a(r^n - 1)}{r - 1}$.

$$S_8 = \frac{a(r^8 - 1)}{r - 1} = \frac{1 \times (2^8 - 1)}{2 - 1} = 256 - 1 = 255$$

(b) $32 + 16 + 8 + \dots$ (10 terms)

In this series $a = 32, r = \frac{1}{2}, n = 10$.

As $|r| < 1$ use $S_n = \frac{a(1 - r^n)}{1 - r}$.

$$S_{10} = \frac{a(1-r^{10})}{1-r} = \frac{32[1 - (\frac{1}{2})^{10}]}{1 - \frac{1}{2}} = 63.938 \text{ (3 d.p.)}$$

(c) $4 - 12 + 36 - 108 + \dots$ (6 terms)

In this series $a = 4$, $r = -3$, $n = 6$.

As $|r| > 1$ use $S_n = \frac{a(r^n - 1)}{r - 1}$.

$$S_6 = \frac{a(r^6 - 1)}{r - 1} = \frac{4[(-3)^6 - 1]}{-3 - 1} = -728$$

(d) $729 - 243 + 81 - \dots - \frac{1}{3}$

In this series $a = 729$, $r = \frac{-243}{729} = -\frac{1}{3}$ and the n th term is $-\frac{1}{3}$.

Using n th term $= ar^{n-1}$

$$-\frac{1}{3} = 729 \times \left(-\frac{1}{3}\right)^{n-1}$$

$$-\frac{1}{2187} = \left(-\frac{1}{3}\right)^{n-1}$$

$$\left(-\frac{1}{3}\right)^7 = \left(-\frac{1}{3}\right)^{n-1}$$

So $n - 1 = 7$

$$\Rightarrow n = 8$$

There are 8 terms in the series.

As $|r| < 1$ use $S_n = \frac{a(1-r^n)}{1-r}$ with $a = 729$, $r = -\frac{1}{3}$ and $n = 8$.

$$S_8 = \frac{729[1 - (-\frac{1}{3})^8]}{1 - (-\frac{1}{3})} = 546\frac{2}{3}$$

6

$$(e) \sum_{r=1} 4^r = 4^1 + 4^2 + 4^3 + \dots + 4^6$$

A geometric series with $a = 4$, $r = 4$ and $n = 6$.

Use $S_n = \frac{a(r^n - 1)}{r - 1}$.

$$\sum_{r=1}^6 4^r = \frac{4(4^6 - 1)}{4 - 1} = 5460$$

8

$$(f) \sum_{r=1} 2 \times (3)^r$$

$$r = 1$$

$$= 2 \times 3^1 + 2 \times 3^2 + 2 \times 3^3 + \dots + 2 \times 3^8$$

$$= 2 \times \underbrace{(3^1 + 3^2 + 3^3 + \dots + 3^8)}$$

A geometric series with $a = 3$, $r = 3$ and $n = 8$.

$$\text{Use } S_n = \frac{a(r^n - 1)}{r - 1}.$$

$$\sum_{r=1}^8 2 \times (3)^r = 2 \times \left[\frac{3(3^8 - 1)}{3 - 1} \right] = 19680$$

$$\begin{aligned} \text{(g) } \sum_{r=1}^{10} 6 \times \left(\frac{1}{2}\right)^r \\ &= 6 \times \left(\frac{1}{2}\right)^1 + 6 \times \left(\frac{1}{2}\right)^2 + \dots + 6 \times \left(\frac{1}{2}\right)^{10} \\ &= 6 \times \left[\left(\frac{1}{2}\right) + \left(\frac{1}{2}\right)^2 + \dots + \left(\frac{1}{2}\right)^{10} \right] \end{aligned}$$

A geometric series with $a = \frac{1}{2}$, $r = \frac{1}{2}$ and $n = 10$.

$$\text{Use } S_n = \frac{a(1 - r^n)}{1 - r}$$

$$\sum_{r=1}^{10} 6 \times \left(\frac{1}{2}\right)^r = 6 \times \frac{\frac{1}{2} [1 - (\frac{1}{2})^{10}]}{1 - \frac{1}{2}} = 5.994 \text{ (3 d.p.)}$$

$$\begin{aligned} \text{(h) } \sum_{r=0}^5 60 \times \left(-\frac{1}{3}\right)^r \\ &= 60 \times \left(-\frac{1}{3}\right)^0 + 60 \times \left(-\frac{1}{3}\right)^1 + \dots + 60 \times \left(-\frac{1}{3}\right)^5 \\ &= 60 \times \left[\left(-\frac{1}{3}\right)^0 + \left(-\frac{1}{3}\right)^1 + \dots + \left(-\frac{1}{3}\right)^5 \right] \\ &= 60 \times \underbrace{\left(1 - \frac{1}{3} + \frac{1}{9} - \dots - \frac{1}{243}\right)} \end{aligned}$$

A geometric series with $a = 1$, $r = -\frac{1}{3}$ and $n = 6$.

$$\text{Use } S_n = \frac{a(1 - r^n)}{1 - r}$$

$$\sum_{r=0}^5 60 \times \left(-\frac{1}{3}\right)^r = 60 \times \frac{1 [1 - (-\frac{1}{3})^6]}{1 - (-\frac{1}{3})} = 44.938 \text{ (3 d.p.)}$$

© Pearson Education Ltd 2008

Solutionbank C2

Edexcel Modular Mathematics for AS and A-Level

Geometric sequences and series

Exercise D, Question 2

Question:

The sum of the first three terms of a geometric series is 30.5. If the first term is 8, find possible values of r .

Solution:

Let the common ratio be r

The first three terms are 8, $8r$ and $8r^2$.

Given that the first three terms add up to 30.5

$$8 + 8r + 8r^2 = 30.5 \quad (\times 2)$$

$$16 + 16r + 16r^2 = 61$$

$$16r^2 + 16r - 45 = 0$$

$$(4r - 5)(4r + 9) = 0$$

$$r = \frac{5}{4}, \frac{-9}{4}$$

Possible values of r are $\frac{5}{4}$ and $\frac{-9}{4}$.

Solutionbank C2

Edexcel Modular Mathematics for AS and A-Level

Geometric sequences and series

Exercise D, Question 3

Question:

The man who invented the game of chess was asked to name his reward. He asked for 1 grain of corn to be placed on the first square of his chessboard, 2 on the second, 4 on the third and so on until all 64 squares were covered. He then said he would like as many grains of corn as the chessboard carried. How many grains of corn did he claim as his prize?

Solution:

$$\text{Number of grains} = \underbrace{1 + 2 + 4 + 8 + \dots}_{64 \text{ terms}}$$

This is a geometric series with $a = 1$, $r = 2$ and $n = 64$.

$$\text{As } |r| > 1 \text{ use } S_n = \frac{a(r^n - 1)}{r - 1}.$$

$$\text{Number of grains} = \frac{1(2^{64} - 1)}{2 - 1} = 2^{64} - 1$$

Solutionbank C2

Edexcel Modular Mathematics for AS and A-Level

Geometric sequences and series

Exercise D, Question 4

Question:

Jane invests £4000 at the start of every year. She negotiates a rate of interest of 4% per annum, which is paid at the end of the year. How much is her investment worth at the end of (a) the 10th year and (b) the 20th year?

Solution:

Start of year 1 Jane has £4000

End of year 1 Jane has 4000×1.04

Start of year 2 Jane has $4000 \times 1.04 + 4000$

End of year 2 Jane has $(4000 \times 1.04 + 4000) \times 1.04$

$= 4000 \times 1.04^2 + 4000 \times 1.04$

⋮

(a) End of year 10 Jane has

$4000 \times 1.04^{10} + 4000 \times 1.04^9 + \dots + 4000 \times 1.04$

$= 4000 \times (1.04^{10} + 1.04^9 + \dots + 1.04)$

A geometric series with $a = 1.04$, $r = 1.04$ and $n = 10$.

$$= 4000 \times \frac{1.04 (1.04^{10} - 1)}{1.04 - 1}$$

$= \text{£}49\,945.41$

(b) End of 20th year

$= 4000 \times (1.04^{20} + 1.04^{19} + \dots + 1.04)$

A geometric series with $a = 1.04$, $r = 1.04$ and $n = 20$.

$$= 4000 \times \frac{1.04 (1.04^{20} - 1)}{1.04 - 1}$$

$= \text{£}123\,876.81$

Solutionbank C2

Edexcel Modular Mathematics for AS and A-Level

Geometric sequences and series

Exercise D, Question 5

Question:

A ball is dropped from a height of 10 m. It bounces to a height of 7 m and continues to bounce. Subsequent heights to which it bounces follow a geometric sequence. Find out:

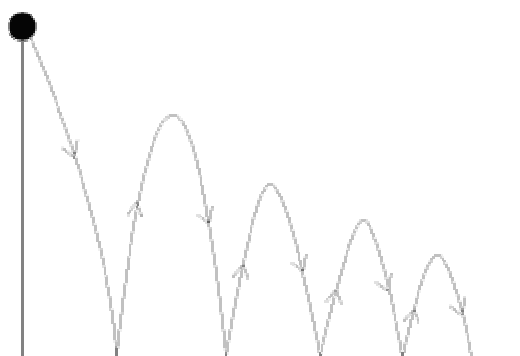

- (a) How high it will bounce after the fourth bounce.
 (b) The total distance travelled after it hits the ground for the sixth time.

Solution:

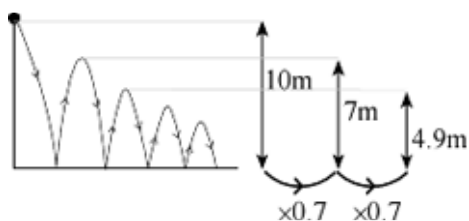

- (a) After the first bounce it bounces to 7m } $\times 0.7$
 After the 2nd bounce it bounces to 4.9m } $\times 0.7$
 After the 3rd bounce it bounces to 3.43m } $\times 0.7$
 After the 4th bounce it bounces to 2.401m } $\times 0.7$

- (b) Total distance travelled

$$= 10 + 7 + 7 + 4.9 + 4.9 + \dots$$

\uparrow 1st bounce \uparrow 2nd bounce \uparrow 3rd bounce

$$= 2 \times (10 + 7 + 4.9 + \dots) - 10$$

$\underbrace{\hspace{10em}}_{\text{6 terms}}$
 $a = 10, r = 0.7, n = 6$

$$= 2 \times \frac{10(1 - 0.7^6)}{1 - 0.7} - 10$$

$$= 48.8234 \text{ m}$$

Solutionbank C2

Edexcel Modular Mathematics for AS and A-Level

Geometric sequences and series

Exercise D, Question 6

Question:

Find the least value of n such that the sum $3 + 6 + 12 + 24 + \dots$ to n terms would first exceed 1.5 million.

Solution:

$3 + 6 + 12 + 24 + \dots$ is a geometric series with $a = 3$, $r = 2$.

$$\text{So } S_n = \frac{a(r^n - 1)}{r - 1} = \frac{3(2^n - 1)}{2 - 1} = 3(2^n - 1)$$

We want $S_n > 1.5$ million

$$S_n > 1\,500\,000$$

$$3(2^n - 1) > 1\,500\,000$$

$$2^n - 1 > 500\,000$$

$$2^n > 500\,001$$

$$\log 2^n > \log 500\,001$$

$$n \log 2 > \log 500\,001$$

$$n > \frac{\log 500\,001}{\log 2}$$

$$n > 18.9$$

Least value of n is 19.

Solutionbank C2

Edexcel Modular Mathematics for AS and A-Level

Geometric sequences and series

Exercise D, Question 7

Question:

Find the least value of n such that the sum $5 + 4.5 + 4.05 + \dots$ to n terms would first exceed 45.

Solution:

$5 + 4.5 + 4.05 + \dots$ is a geometric series with $a = 5$ and $r = \frac{4.5}{5} = 0.9$.

$$\text{Using } S_n = \frac{a(1-r^n)}{1-r} = \frac{5(1-0.9^n)}{1-0.9} = 50 \left(1 - 0.9^n \right)$$

We want $S_n > 45$

$$50(1 - 0.9^n) > 45$$

$$\left(1 - 0.9^n \right) > \frac{45}{50}$$

$$1 - 0.9^n > 0.9$$

$$0.9^n < 0.1$$

$$\log (0.9)^n < \log (0.1)$$

$$n \log (0.9) < \log (0.1)$$

$$n > \frac{\log (0.1)}{\log (0.9)}$$

$$n > 21.85$$

$$\text{So } n = 22$$

Solutionbank C2

Edexcel Modular Mathematics for AS and A-Level

Geometric sequences and series

Exercise D, Question 8

Question:

Richard is sponsored to cycle 1000 miles over a number of days. He cycles 10 miles on day 1, and increases this distance by 10% a day. How long will it take him to complete the challenge? What was the greatest number of miles he completed in a single day?

Solution:

$$\begin{array}{l}
 \text{Day one} = 10 \text{ miles} \\
 \text{Day two} = 10 \times 1.1 = 11 \text{ miles} \\
 \text{Day three} = 11 \times 1.1 = 12.1 \text{ miles} \\
 \vdots \\
 \text{We want } \underbrace{10 + 11 + 12.1 + \dots}_{n \text{ days}} = 1000
 \end{array}$$

Use the sum formula $S_n = \frac{a(r^n - 1)}{r - 1}$ with $a = 10$, $r = 1.1$.

$$\frac{10(1.1^n - 1)}{1.1 - 1} = 1000$$

$$\frac{10(1.1^n - 1)}{0.1} = 1000$$

$$1.1^n - 1 = 10$$

$$1.1^n = 11$$

$$\log 1.1^n = \log 11$$

$$n \log 1.1 = \log 11$$

$$n = \frac{\log 11}{\log 1.1}$$

$$n = 25.16 \text{ days}$$

It would take him 26 days to complete the challenge.

He would complete most miles on day 25

$$= 10 \times 1.1^{24} \text{ (using } ar^{n-1} \text{)}$$

$$= 98.5 \text{ miles (3 s.f.)}$$

Solutionbank C2

Edexcel Modular Mathematics for AS and A-Level

Geometric sequences and series

Exercise D, Question 9

Question:

A savings scheme is offering a rate of interest of 3.5% per annum for the lifetime of the plan. Alan wants to save up £20 000. He works out that he can afford to save £500 every year, which he will deposit on January 1st. If interest is paid on 31st of December, how many years will it be before he has saved up his £20 000?

Solution:

Jan. 1st year 1 = £500

Dec. 31st year 1 = 500×1.035

Jan. 1st year 2 = $500 \times 1.035 + 500$

Dec. 31st year 2 = $(500 \times 1.035 + 500) \times 1.035 = 500 \times 1.035^2 + 500 \times 1.035$

⋮

Dec. 31st year n

= $500 \times 1.035^n + \dots + 500 \times 1.035^2 + 500 \times 1.035$

= $500 \times \underbrace{(1.035^n + \dots + 1.035^2 + 1.035)}$

A geometric series with $a = 1.035$, $r = 1.035$ and n .

Use $S_n = \frac{a(r^n - 1)}{r - 1}$.

Dec. 31st year $n = 500 \times \frac{1.035(1.035^n - 1)}{1.035 - 1}$

Set this equal to £20 000

$20\,000 = 500 \times \frac{1.035(1.035^n - 1)}{1.035 - 1}$

$$\left(1.035^n - 1 \right) = \frac{20\,000 \times (1.035 - 1)}{500 \times 1.035}$$

$1.035^n - 1 = 1.3526570 \dots$

$1.035^n = 2.3526570 \dots$

$\log(1.035^n) = \log 2.3526570 \dots$

$n \log(1.035) = \log 2.3526570 \dots$

$n = \frac{\log 2.3526570 \dots}{\log 1.035}$

$n = 24.9$ years (3 s.f.)

It takes Alan 25 years to save £20 000.

Solutionbank C2

Edexcel Modular Mathematics for AS and A-Level

Geometric sequences and series

Exercise E, Question 1

Question:

Find the sum to infinity, if it exists, of the following series:

(a) $1 + 0.1 + 0.01 + 0.001 + \dots$

(b) $1 + 2 + 4 + 8 + 16 + \dots$

(c) $10 - 5 + 2.5 - 1.25 + \dots$

(d) $2 + 6 + 10 + 14$

(e) $1 + 1 + 1 + 1 + 1 + \dots$

(f) $3 + 1 + \frac{1}{3} + \frac{1}{9} + \dots$

(g) $0.4 + 0.8 + 1.2 + 1.6 + \dots$

(h) $9 + 8.1 + 7.29 + 6.561 + \dots$

(i) $1 + r + r^2 + r^3 + \dots$

(j) $1 - 2x + 4x^2 - 8x^3 + \dots$

Solution:

(a) $1 + 0.1 + 0.01 + 0.001 + \dots$

As $r = 0.1$, S_{∞} exists.

$$S_{\infty} = \frac{a}{1-r} = \frac{1}{1-0.1} = \frac{1}{0.9} = \frac{10}{9}$$

(b) $1 + 2 + 4 + 8 + 16 + \dots$

As $r = 2$, S_{∞} does not exist.

(c) $10 - 5 + 2.5 - 1.25 + \dots$

As $r = -\frac{1}{2}$, S_{∞} exists.

$$S_{\infty} = \frac{a}{1-r} = \frac{10}{1 - (-\frac{1}{2})} = \frac{10}{\frac{3}{2}} = 10 \times \frac{2}{3} = \frac{20}{3} = 6\frac{2}{3}$$

(d) $2 + 6 + 10 + 14 + \dots$

This is an arithmetic series.

S_{∞} does not exist.

(e) $1 + 1 + 1 + 1 + 1 + \dots$

As $r = 1$, S_{∞} does not exist.

$$(f) 3 + 1 + \frac{1}{3} + \frac{1}{9} + \dots$$

As $r = \frac{1}{3}$, S_{∞} exists.

$$S_{\infty} = \frac{a}{1-r} = \frac{3}{1-\frac{1}{3}} = \frac{3}{\frac{2}{3}} = 3 \times \frac{3}{2} = \frac{9}{2} = 4 \frac{1}{2}$$

$$(g) 0.4 + 0.8 + 1.2 + 1.6 + \dots$$

This is an arithmetic series.

S_{∞} does not exist.

$$(h) 9 + 8.1 + 7.29 + 6.561 + \dots$$

As $r = \frac{8.1}{9} = 0.9$, S_{∞} exists.

$$S_{\infty} = \frac{a}{1-r} = \frac{9}{1-0.9} = \frac{9}{0.1} = 90$$

$$(i) 1 + r + r^2 + r^3 + \dots$$

S_{∞} exists if $|r| < 1$.

$$S_{\infty} = \frac{1}{1-r} \text{ if } |r| < 1$$

$$(j) 1 - 2x + 4x^2 - 8x^3 + \dots$$

As $r = -2x$, S_{∞} exists if $\left| -2x \right| < 1 \Rightarrow \left| x \right| < \frac{1}{2}$.

$$S_{\infty} = \frac{1}{1-(-2x)} = \frac{1}{1+2x} \text{ if } \left| x \right| < \frac{1}{2}$$

Solutionbank C2

Edexcel Modular Mathematics for AS and A-Level

Geometric sequences and series

Exercise E, Question 2

Question:

Find the common ratio of a geometric series with a first term of 10 and a sum to infinity of 30.

Solution:

Substitute $a = 10$ and $S_{\infty} = 30$ into

$$S_{\infty} = \frac{a}{1-r}$$

$$30 = \frac{10}{1-r} \times (1-r)$$

$$30(1-r) = 10 \quad (\div 30)$$

$$1-r = \frac{10}{30}$$

$$1-r = \frac{1}{3}$$

$$1 = \frac{1}{3} + r$$

$$\frac{2}{3} = r$$

The common ratio is $\frac{2}{3}$.

Solutionbank C2

Edexcel Modular Mathematics for AS and A-Level

Geometric sequences and series

Exercise E, Question 3

Question:

Find the common ratio of a geometric series with a first term of -5 and a sum to infinity of -3 .

Solution:

Substitute $a = -5$ and $S_{\infty} = -3$ into

$$S_{\infty} = \frac{a}{1-r}$$

$$-3 = \frac{-5}{1-r}$$

$$-3(1-r) = -5$$

$$1-r = \frac{-5}{-3}$$

$$1-r = +\frac{5}{3}$$

$$1 = \frac{5}{3} + r$$

$$1 - \frac{5}{3} = r$$

$$-\frac{2}{3} = r$$

© Pearson Education Ltd 2008

Solutionbank C2

Edexcel Modular Mathematics for AS and A-Level

Geometric sequences and series

Exercise E, Question 4

Question:

Find the first term of a geometric series with a common ratio of $\frac{2}{3}$ and a sum to infinity of 60.

Solution:

Substitute $r = \frac{2}{3}$ and $S_{\infty} = 60$ into

$$S_{\infty} = \frac{a}{1-r}$$

$$60 = \frac{a}{1 - \frac{2}{3}} \text{ (simplify denominator)}$$

$$60 = \frac{a}{\frac{1}{3}} \text{ (multiply by } \frac{1}{3} \text{)}$$

$$60 \times \frac{1}{3} = a$$

$$20 = a$$

The first term is 20.

© Pearson Education Ltd 2008

Solutionbank C2

Edexcel Modular Mathematics for AS and A-Level

Geometric sequences and series

Exercise E, Question 5

Question:

Find the first term of a geometric series with a common ratio of $-\frac{1}{3}$ and a sum to infinity of 10.

Solution:

Substitute $S_{\infty} = 10$ and $r = -\frac{1}{3}$ into

$$S_{\infty} = \frac{a}{1-r}$$

$$10 = \frac{a}{1 - \left(-\frac{1}{3}\right)}$$

$$10 = \frac{a}{\frac{4}{3}}$$

$$\frac{4}{3} \times 10 = a$$

$$a = \frac{40}{3}$$

The first term is $\frac{40}{3}$.

Solutionbank C2

Edexcel Modular Mathematics for AS and A-Level

Geometric sequences and series

Exercise E, Question 6

Question:

Find the fraction equal to the recurring decimal 0.2323232323.

Solution:

$$0.23232323 \dots =$$

$$\frac{23}{100} + \frac{23}{10000} + \frac{23}{1000000} + \dots$$

This is an infinite geometric series with $a = \frac{23}{100}$ and $r = \frac{1}{100}$.

Use $S_{\infty} = \frac{a}{1-r}$.

$$0.23232323 \dots = \frac{\frac{23}{100}}{1 - \frac{1}{100}} = \frac{\frac{23}{100}}{\frac{99}{100}} = \frac{23}{100} \times \frac{100}{99} = \frac{23}{99}$$

Solutionbank C2

Edexcel Modular Mathematics for AS and A-Level

Geometric sequences and series

Exercise E, Question 7

Question:

$$\text{Find } \sum_{r=1}^{\infty} 4(0.5)^r.$$

Solution:

$$\begin{aligned} & \sum_{r=1}^{\infty} 4(0.5)^r \\ &= 4(0.5)^1 + 4(0.5)^2 + 4(0.5)^3 + \dots \\ &= 4 \times \underbrace{(0.5^1 + 0.5^2 + 0.5^3 + \dots)} \end{aligned}$$

This is an infinite geometric series with $a = 0.5$ and $r = 0.5$.

$$\text{Use } S_{\infty} = \frac{a}{1-r}.$$

$$\begin{aligned} \sum_{r=1}^{\infty} 4(0.5)^r &= 4 \times \frac{0.5}{1-0.5} = 4 \times \frac{0.5}{0.5} = 4 \\ & r = 1 \end{aligned}$$

Solutionbank C2

Edexcel Modular Mathematics for AS and A-Level

Geometric sequences and series

Exercise E, Question 8

Question:

A ball is dropped from a height of 10 m. It bounces to a height of 6 m, then 3.6, and so on following a geometric sequence.

Find the total distance travelled by the ball.

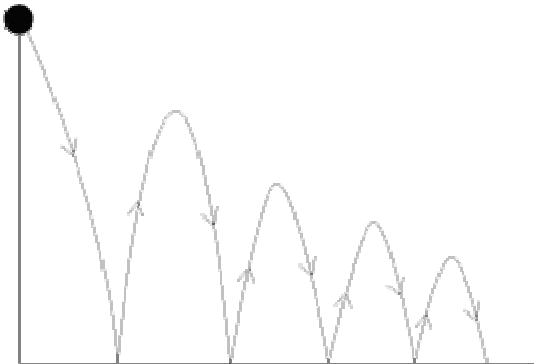

Solution:

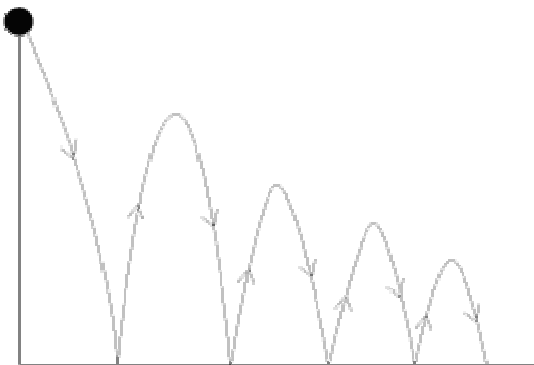

Total distance

$$\begin{aligned}
 &= 10 + 6 + 6 + 3.6 + 3.6 + 2.16 + 2.16 + \dots \\
 &\quad \underbrace{\hspace{1.5cm}}_{\times 0.6} \quad \underbrace{\hspace{1.5cm}}_{\times 0.6} \quad \underbrace{\hspace{1.5cm}}_{\times 0.6} \\
 &= 2 \times (10 + 6 + 3.6 + 2.16 + \dots) - 10
 \end{aligned}$$

This is an infinite geometric series with $a = 10$, $r = 0.6$.

Use $S_{\infty} = \frac{a}{1-r}$.

$$\text{Total distance} = 2 \times \frac{10}{1-0.6} - 10 = 2 \times \frac{10}{0.4} - 10 = 50 - 10 = 40 \text{ m}$$

Solutionbank C2

Edexcel Modular Mathematics for AS and A-Level

Geometric sequences and series

Exercise E, Question 9

Question:

The sum to three terms of a geometric series is 9 and its sum to infinity is 8. What could you deduce about the common ratio? Why? Find the first term and common ratio.

Solution:

Let a = first term and r = common ratio.

If S_{∞} exists then $|r| < 1$.

In fact as $S_{\infty} < S_3$ r must also be negative.

$$\text{Using } S_3 = 9 \Rightarrow \frac{a(1-r^3)}{1-r} = 9 \quad \textcircled{1}$$

$$\text{and } S_{\infty} = 8 \Rightarrow \frac{a}{1-r} = 8 \quad \textcircled{2}$$

Substitute $\textcircled{2}$ in $\textcircled{1}$:

$$8(1-r^3) = 9$$

$$1-r^3 = \frac{9}{8}$$

$$r^3 = -\frac{1}{8}$$

$$r = -\frac{1}{2}$$

Substitute $r = -\frac{1}{2}$ back into Equation $\textcircled{2}$:

$$\frac{a}{1 - (-\frac{1}{2})} = 8$$

$$a = 8 \times \frac{3}{2}$$

$$a = 12$$

Solutionbank C2

Edexcel Modular Mathematics for AS and A-Level

Geometric sequences and series

Exercise E, Question 10

Question:

The sum to infinity of a geometric series is three times the sum to 2 terms. Find all possible values of the common ratio.

Solution:

Let a = first term and r = common ratio.

We are told $S_{\infty} = 3 \times S_2$

$$\Rightarrow \frac{a}{1-r} = 3 \times \frac{a(1+r)}{1-r}$$

$$\Rightarrow 1 = 3(1+r)$$

$$\Rightarrow 1 = 3 + 3r$$

$$\Rightarrow 3r = -2$$

$$\Rightarrow r = -\frac{2}{3}$$

$$\Rightarrow r = \pm \sqrt{\frac{2}{3}}$$

Solutionbank C2

Edexcel Modular Mathematics for AS and A-Level

Geometric sequences and series

Exercise F, Question 1

Question:

State which of the following series are geometric. For the ones that are, give the value of the common ratio r .

(a) $4 + 7 + 10 + 13 + 16 + \dots$

(b) $4 + 6 + 9 + 13.5 + \dots$

(c) $20 + 10 + 5 + 2.5 + \dots$

(d) $4 - 8 + 16 - 32 + \dots$

(e) $4 - 2 - 8 - 14 - \dots$

(f) $1 + 1 + 1 + 1 + \dots$

Solution:

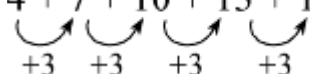
(a) $4 + 7 + 10 + 13 + 16 + \dots$

Not geometric—you are adding 3 each time.

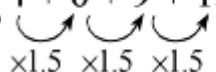
(b) $4 + 6 + 9 + 13.5 + \dots$

Geometric with $a = 4$ and $r = 1.5$.

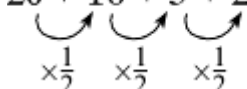
(c) $20 + 10 + 5 + 2.5 + \dots$

Geometric with $a = 20$ and $r = \frac{1}{2}$.

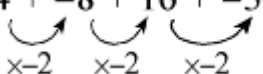
(d) $4 - 8 + 16 - 32 + \dots$
 $4 + -8 + 16 + -32 + \dots$

Geometric with $a = 4$ and $r = -2$.

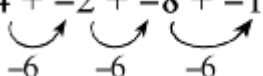
(e) $4 - 2 - 8 - 14 + \dots$
 $4 + -2 + -8 + -14 + \dots$

Not geometric—you are subtracting 6 each time.

(f) $1 + 1 + 1 + 1 + \dots$

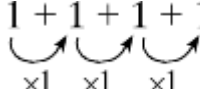

$\times 1 \quad \times 1 \quad \times 1$

Geometric with $a = 1$ and $r = 1$.

© Pearson Education Ltd 2008

Solutionbank C2

Edexcel Modular Mathematics for AS and A-Level

Geometric sequences and series

Exercise F, Question 2

Question:

Find the 8th and n th terms of the following geometric sequences:

(a) 10, 7, 4.9, ...

(b) 5, 10, 20, ...

(c) 4, -4, 4, ...

(d) 3, -1.5, 0.75, ...

Solution:

(a) 10, 7, 4.9, ...

$$a = 10, r = \frac{\text{2nd term}}{\text{1st term}} = \frac{7}{10} = 0.7$$

$$\text{8th term} = 10 \times (0.7)^{8-1} = 10 \times 0.7^7 = 0.823543$$

$$\text{nth term} = 10 \times (0.7)^{n-1}$$

(b) 5, 10, 20, ...

$$a = 5, r = \frac{10}{5} = 2$$

$$\text{8th term} = 5 \times 2^{8-1} = 5 \times 2^7 = 640$$

$$\text{nth term} = 5 \times 2^{n-1}$$

(c) 4, -4, 4, ...

$$a = 4, r = \frac{-4}{4} = -1$$

$$\text{8th term} = 4 \times (-1)^{8-1} = 4 \times (-1)^7 = -4$$

$$\text{nth term} = 4 \times (-1)^{n-1}$$

(d) 3, -1.5, 0.75, ...

$$a = 3, r = \frac{-1.5}{3} = -0.5$$

$$\text{8th term} = 3 \times (-0.5)^{8-1} = 3 \times (-0.5)^7 = \frac{-3}{128} = -0.0234375$$

$$\text{nth term} = 3 \times (-0.5)^{n-1} = 3 \times \left(-\frac{1}{2}\right)^{n-1}$$

Solutionbank C2

Edexcel Modular Mathematics for AS and A-Level

Geometric sequences and series

Exercise F, Question 3

Question:

Find the sum to 10 terms of the following geometric series:

(a) $4 + 8 + 16 + \dots$

(b) $30 - 15 + 7.5 - \dots$

(c) $5 + 5 + 5 + \dots$

(d) $2 + 0.8 + 0.32 - \dots$

Solution:

(a) $4 + 8 + 16 + \dots$

$a = 4, r = 2$

As $|r| > 1$ use $S_n = \frac{a(r^n - 1)}{r - 1}$

$$S_{10} = \frac{4(2^{10} - 1)}{2 - 1} = 4092$$

(b) $30 - 15 + 7.5 + \dots$

$a = 30, r = -\frac{1}{2}$

As $|r| < 1$ use $S_n = \frac{a(1 - r^n)}{1 - r}$

$$S_{10} = \frac{30[1 - (-\frac{1}{2})^{10}]}{1 - (-\frac{1}{2})} = \frac{30[1 - (-\frac{1}{2})^{10}]}{1 + \frac{1}{2}} = 19.98 \text{ (2 d.p.)}$$

(c) $5 + 5 + 5 + \dots$

$a = 5, r = 1$

As $r = 1$ the sum formulae cannot be used.

$$S_{10} = \underbrace{5+5+5+\dots+5}_{10 \text{ terms}} = 50$$

(d) $2 + 0.8 + 0.32 + \dots$

$a = 2, r = \frac{0.8}{2} = 0.4$

As $|r| < 1$ use $S_n = \frac{a(1 - r^n)}{1 - r}$

$$S_{10} = \frac{2[1 - (0.4)^{10}]}{1 - 0.4} = \frac{2[1 - (0.4)^{10}]}{0.6} = 3.33 \text{ (2 d.p.)}$$

Solutionbank C2

Edexcel Modular Mathematics for AS and A-Level

Geometric sequences and series

Exercise F, Question 4

Question:

Determine which of the following geometric series converge. For the ones that do, give the limiting value of this sum (i.e. S_{∞}).

(a) $6 + 2 + \frac{2}{3} + \dots$

(b) $4 - 2 + 1 - \dots$

(c) $5 + 10 + 20 + \dots$

(d) $4 + 1 + 0.25 + \dots$

Solution:

(a) $6 + 2 + \frac{2}{3} + \dots$

$$a = 6 \text{ and } r = \frac{2}{6} = \frac{1}{3}$$

As $|r| < 1$ series converges with limit

$$S_{\infty} = \frac{a}{1-r} = \frac{6}{1-\frac{1}{3}} = \frac{6}{\frac{2}{3}} = 9$$

(b) $4 - 2 + 1 - \dots$
 $= (4) + (-2) + (1) + \dots$

$$a = 4 \text{ and } r = -\frac{2}{4} = -\frac{1}{2}$$

As $|r| < 1$ series converges with limit

$$S_{\infty} = \frac{a}{1-r} = \frac{4}{1-(-\frac{1}{2})} = \frac{4}{\frac{3}{2}} = \frac{8}{3}$$

(c) $5 + 10 + 20 + \dots$

$$a = 5, r = 2$$

As $|r| > 1$ series does not converge.

(d) $4 + 1 + 0.25 + \dots$

$$a = 4 \text{ and } r = \frac{1}{4}$$

As $|r| < 1$ series converges with limit

$$S_{\infty} = \frac{a}{1-r} = \frac{4}{1-\frac{1}{4}} = \frac{4}{\frac{3}{4}} = \frac{16}{3}$$

Solutionbank C2

Edexcel Modular Mathematics for AS and A-Level

Geometric sequences and series

Exercise F, Question 5

Question:

A geometric series has third term 27 and sixth term 8:

(a) Show that the common ratio of the series is $\frac{2}{3}$.

(b) Find the first term of the series.

(c) Find the sum to infinity of the series.

(d) Find, to 3 significant figures, the difference between the sum of the first 10 terms of the series and the sum to infinity of the series.

[E]

Solution:

(a) Let a = first term and r = common ratio.

$$3\text{rd term} = 27 \Rightarrow ar^2 = 27 \quad \textcircled{1}$$

$$6\text{th term} = 8 \Rightarrow ar^5 = 8 \quad \textcircled{2}$$

Equation $\textcircled{2} \div \textcircled{1}$:

$$\frac{ar^5}{ar^2} = \frac{8}{27} \quad \left(\frac{r^5}{r^2} = r^{5-2} \right)$$

$$r^3 = \frac{8}{27}$$

$$r = \sqrt[3]{\frac{8}{27}} = \frac{2}{3}$$

The common ratio is $\frac{2}{3}$.

(b) Substitute $r = \frac{2}{3}$ back into Equation $\textcircled{1}$:

$$a \times \left(\frac{2}{3} \right)^2 = 27$$

$$a \times \frac{4}{9} = 27$$

$$a = \frac{27 \times 9}{4}$$

$$a = 60.75$$

The first term is 60.75

(c) Sum to infinity = $\frac{a}{1-r}$

$$\Rightarrow S_{\infty} = \frac{60.75}{1 - \frac{2}{3}} = \frac{60.75}{\frac{1}{3}} = 182.25$$

Sum to infinity is 182.25

$$(d) \text{ Sum to ten terms} = \frac{a(1-r^{10})}{1-r}$$

$$\text{So } S_{10} = \frac{60.75 [1 - (\frac{2}{3})^{10}]}{(1 - \frac{2}{3})} = \frac{60.75 [1 - (\frac{2}{3})^{10}]}{\frac{1}{3}} = 179.0895 \dots$$

$$\text{Difference between } S_{10} \text{ and } S_{\infty} = 182.25 - 179.0895 = 3.16 \text{ (3 s.f.)}$$

© Pearson Education Ltd 2008

Solutionbank C2

Edexcel Modular Mathematics for AS and A-Level

Geometric sequences and series

Exercise F, Question 6

Question:

The second term of a geometric series is 80 and the fifth term of the series is 5.12:

(a) Show that the common ratio of the series is 0.4.

Calculate:

(b) The first term of the series.

(c) The sum to infinity of the series, giving your answer as an exact fraction.

(d) The difference between the sum to infinity of the series and the sum of the first 14 terms of the series, giving your answer in the form $a \times 10^n$, where $1 \leq a < 10$ and n is an integer.

[E]

Solution:

$$(a) \text{ 2nd term is } 80 \Rightarrow ar^{2-1} = 80 \Rightarrow ar = 80 \quad \textcircled{1}$$

$$\text{5th term is } 5.12 \Rightarrow ar^{5-1} = 5.12 \Rightarrow ar^4 = 5.12 \quad \textcircled{2}$$

Equation $\textcircled{2} \div$ Equation $\textcircled{1}$:

$$\frac{ar^4}{ar} = \frac{5.12}{80}$$

$$r^3 = 0.064 \quad \left(\sqrt[3]{\quad} \right)$$

$$r = 0.4$$

Hence common ratio = 0.4

(b) substitute $r = 0.4$ into Equation $\textcircled{1}$:

$$a \times 0.4 = 80 \quad (\div 0.4)$$

$$a = 200$$

The first term in the series is 200.

$$(c) \text{ Sum to infinity} = \frac{a}{1-r} = \frac{200}{1-0.4} = \frac{200}{0.6} = 333 \frac{1}{3}$$

$$(d) \text{ Sum to } n \text{ terms} = \frac{a(1-r^n)}{1-r}$$

$$\text{So } S_{14} = \frac{200(1-0.4^{14})}{(1-0.4)} = 333.3324385$$

$$\text{Required difference } S_{14} - S_{\infty} = 333.3324385 - 333 \frac{1}{3} = 0.0008947 = 8.95 \times 10^{-4} \text{ (3 s.f.)}$$

Solutionbank C2

Edexcel Modular Mathematics for AS and A-Level

Geometric sequences and series

Exercise F, Question 7

Question:

The n th term of a sequence is u_n , where $u_n = 95 \left(\frac{4}{5} \right)^n$, $n = 1, 2, 3, \dots$

(a) Find the value of u_1 and u_2 .

Giving your answers to 3 significant figures, calculate:

(b) The value of u_{21} .

(c) $\sum_{n=1}^{15} u_n$

(d) Find the sum to infinity of the series whose first term is u_1 and whose n th term is u_n .

[E]

Solution:

$$(a) u_n = 95 \left(\frac{4}{5} \right)^n$$

$$\text{Replace } n \text{ with } 1 \Rightarrow u_1 = 95 \left(\frac{4}{5} \right)^1 = 76$$

$$\text{Replace } n \text{ with } 2 \Rightarrow u_2 = 95 \left(\frac{4}{5} \right)^2 = 60.8$$

$$(b) \text{ Replace } n \text{ with } 21 \Rightarrow u_{21} = 95 \left(\frac{4}{5} \right)^{21} = 0.876 \text{ (3 s.f.)}$$

$$(c) \sum_{n=1}^{15} u_n = \underbrace{76 + 60.8 + \dots + 95\left(\frac{4}{5}\right)^{15}}_{15 \text{ terms}}$$

A geometric series with $a = 76$ and $r = \frac{4}{5}$.

$$\text{Use } S_n = \frac{a(1-r^n)}{1-r}$$

$$\sum_{n=1}^{15} u_n = \frac{76 \left[1 - \left(\frac{4}{5} \right)^{15} \right]}{1 - \frac{4}{5}} = \frac{76 \left[1 - \left(\frac{4}{5} \right)^{15} \right]}{\frac{1}{5}} \quad \left(\div \frac{1}{5} \text{ is equivalent to } \times 5 \right)$$

$$\sum_{n=1}^{15} u_n = 76 \times 5 \times \left[1 - \left(\frac{4}{5} \right)^{15} \right] = 366.63 = 367 \text{ (to 3 s.f.)}$$

$$(d) S_{\infty} = \frac{a}{1-r} = \frac{76}{1 - \frac{4}{5}} = \frac{76}{\frac{1}{5}} = 76 \times 5 = 380$$

Sum to infinity is 380.

© Pearson Education Ltd 2008

Solutionbank C2

Edexcel Modular Mathematics for AS and A-Level

Geometric sequences and series

Exercise F, Question 8

Question:

A sequence of numbers $u_1, u_2, \dots, u_n, \dots$ is given by the formula $u_n = 3 \left(\frac{2}{3} \right)^n - 1$ where n is a positive integer.

(a) Find the values of u_1, u_2 and u_3 .

15

(b) Show that $\sum_{n=1}^{15} u_n = -9.014$ to 4 significant figures.

(c) Prove that $u_{n+1} = 2 \left(\frac{2}{3} \right)^n - 1$.

[E]

Solution:

$$(a) u_n = 3 \left(\frac{2}{3} \right)^n - 1$$

$$\text{Replace } n \text{ with } 1 \Rightarrow u_1 = 3 \times \left(\frac{2}{3} \right)^1 - 1 = 2 - 1 = 1$$

$$\text{Replace } n \text{ with } 2 \Rightarrow u_2 = 3 \times \left(\frac{2}{3} \right)^2 - 1 = 3 \times \frac{4}{9} - 1 = \frac{1}{3}$$

$$\text{Replace } n \text{ with } 3 \Rightarrow u_3 = 3 \times \left(\frac{2}{3} \right)^3 - 1 = 3 \times \frac{8}{27} - 1 = -\frac{1}{9}$$

$$(b) \sum_{n=1}^{15} u_n = \left[3 \times \left(\frac{2}{3} \right)^1 - 1 \right] + \left[3 \times \left(\frac{2}{3} \right)^2 - 1 \right] + \left[3 \times \left(\frac{2}{3} \right)^3 - 1 \right] \\ + \dots + \left[3 \times \left(\frac{2}{3} \right)^{15} - 1 \right]$$

$$= \underbrace{3 \times \left(\frac{2}{3} \right) + 3 \times \left(\frac{2}{3} \right)^2 + 3 \times \left(\frac{2}{3} \right)^3 + \dots + 3 \times \left(\frac{2}{3} \right)^{15}}_{\substack{\text{a geometric series with 15 terms,} \\ \text{where } a = 3 \times \frac{2}{3} = 2 \text{ and } r = \frac{2}{3}}} - \underbrace{1 - 1 - 1 - \dots - 1}_{15 \text{ times}}$$

$$\text{Use } S_n = \frac{a(1-r^n)}{1-r}$$

$$\sum_{n=1}^{15} u_n = \frac{2[1 - (\frac{2}{3})^{15}]}{1 - \frac{2}{3}} - 15 = 5.986 \dots - 15 = -9.0137 \dots = -9.014 \text{ (4 s.f.)}$$

$$(c) u_{n+1} = 3 \times \left(\frac{2}{3}\right)^{n+1} - 1 = 3 \times \frac{2}{3} \times \left(\frac{2}{3}\right)^n - 1 = 2 \left(\frac{2}{3}\right)^n - 1$$

© Pearson Education Ltd 2008

Solutionbank C2

Edexcel Modular Mathematics for AS and A-Level

Geometric sequences and series

Exercise F, Question 9

Question:

The third and fourth terms of a geometric series are 6.4 and 5.12 respectively. Find:

- The common ratio of the series.
- The first term of the series.
- The sum to infinity of the series.
- Calculate the difference between the sum to infinity of the series and the sum of the first 25 terms of the series.

[E]

Solution:

- (a) Let a = first term and r = the common ratio of the series.

We are given

$$3\text{rd term} = 6.4 \Rightarrow ar^2 = 6.4 \quad \textcircled{1}$$

$$4\text{th term} = 5.12 \Rightarrow ar^3 = 5.12 \quad \textcircled{2}$$

Equation $\textcircled{2} \div$ Equation $\textcircled{1}$:

$$\frac{ar^3}{ar^2} = \frac{5.12}{6.4}$$

$$r = 0.8$$

The common ratio is 0.8.

- (b) Substitute $r = 0.8$ into Equation $\textcircled{1}$:

$$a \times 0.8^2 = 6.4$$

$$a = \frac{6.4}{0.8^2}$$

$$a = 10$$

The first term is 10.

- (c) Use $S_{\infty} = \frac{a}{1-r}$ with $a = 10$ and $r = 0.8$.

$$S_{\infty} = \frac{10}{1-0.8} = \frac{10}{0.2} = 50$$

Sum to infinity is 50.

$$(d) S_{25} = \frac{a(1-r^{25})}{1-r} = \frac{10(1-0.8^{25})}{1-0.8} = 49.8111 \dots$$

$$S_{\infty} - S_{25} = 50 - 49.8111 \dots \\ = 0.189 \text{ (3 s.f.)}$$

Solutionbank C2

Edexcel Modular Mathematics for AS and A-Level

Geometric sequences and series

Exercise F, Question 10

Question:

The price of a car depreciates by 15% per annum. If its new price is £20 000, find:

- (a) A formula linking its value £ V with its age a years.
- (b) Its value after 5 years.
- (c) The year in which it will be worth less than £4000.

Solution:

(a) If rate of depreciation is 15%, then car is worth 0.85 of its value at the start of the year.

New price = £20 000

After 1 year value = $20\,000 \times 0.85$

After 2 years value = $20\,000 \times 0.85 \times 0.85 = 20\,000 \times (0.85)^2$

⋮

After a year value $V = 20\,000 \times (0.85)^a$

(b) Substitute $a = 5$:

$V = 20\,000 \times (0.85)^5 = 8874.10625$

Value of car after 5 years is £8874.11

(c) When value equals £4000

$4000 = 20\,000 \times (0.85)^a$ ($\div 20\,000$)

$0.2 = (0.85)^a$ (take logs both sides)

$\log (0.2) = \log (0.85)^a$ (use $\log a^n = n \log a$)

$\log (0.2) = a \log (0.85)$ [$\div \log (0.85)$]

$$a = \frac{\log (0.2)}{\log (0.85)}$$

$a = 9.90 \dots$

It will be worth less than £4000 in the 10th year.

Solutionbank C2

Edexcel Modular Mathematics for AS and A-Level

Geometric sequences and series

Exercise F, Question 11

Question:

The first three terms of a geometric series are $p(3q + 1)$, $p(2q + 2)$ and $p(2q - 1)$ respectively, where p and q are non-zero constants.

(a) Use algebra to show that one possible value of q is 5 and to find the other possible value of q .

(b) For each possible value of q , calculate the value of the common ratio of the series.

Given that $q = 5$ and that the sum to infinity of the geometric series is 896, calculate:

(c) The value of p .

(d) The sum, to 2 decimal places, of the first twelve terms of the series.

[E]

Solution:

(a) If $p(3q + 1)$, $p(2q + 2)$ and $p(2q - 1)$ are consecutive terms in a geometric series then

$$\frac{p(2q+2)}{p(3q+1)} = \frac{p(2q-1)}{p(2q+2)}$$

$$\frac{2q+2}{3q+1} = \frac{2q-1}{2q+2} \text{ (cross multiply)}$$

$$(2q+2)(2q+2) = (2q-1)(3q+1)$$

$$4q^2 + 8q + 4 = 6q^2 - 1q - 1$$

$$0 = 2q^2 - 9q - 5$$

$$0 = (2q+1)(q-5)$$

$$q = -\frac{1}{2}, 5$$

(b) When $q = 5$ terms are $p(3 \times 5 + 1)$, $p(2 \times 5 + 2)$, $p(2 \times 5 - 1) = 16p$, $12p$ and $9p$

$$\text{Common ratio} = \frac{12p}{16p} = \frac{3}{4}$$

$$\text{When } q = -\frac{1}{2} \text{ terms are } p \left(3 \times -\frac{1}{2} + 1 \right), p \left(2 \times -\frac{1}{2} + 2 \right), p \left(2 \times -\frac{1}{2} - 1 \right) = -\frac{1}{2}p, 1p, -2p$$

$$\text{Common ratio} = \frac{1p}{-\frac{1}{2}p} = -2$$

(c) When $q = 5$ terms are $16p$, $12p$ and $9p$

$$\text{Using } S_{\infty} = \frac{a}{1-r}$$

$$896 = \frac{16p}{1 - \frac{3}{4}}$$

$$896 = \frac{16p}{\frac{1}{4}} \left(\times \frac{1}{4} \right)$$

$$224 = 16p$$

$$14 = p$$

Therefore $p = 14$

(d) Using $S_n = \frac{a(1-r^n)}{1-r}$

$$S_{12} = \frac{16p \left[1 - \left(\frac{3}{4} \right)^{12} \right]}{1 - \frac{3}{4}}$$

$$p = 14 \Rightarrow S_{12} = \frac{16 \times 14 \left[1 - \left(\frac{3}{4} \right)^{12} \right]}{\frac{1}{4}} = 867.617 \dots = 867.62 \text{ (2 d.p.)}$$

© Pearson Education Ltd 2008

Solutionbank C2

Edexcel Modular Mathematics for AS and A-Level

Geometric sequences and series

Exercise F, Question 12

Question:

A savings scheme pays 5% per annum compound interest. A deposit of £100 is invested in this scheme at the start of each year.

(a) Show that at the start of the third year, after the annual deposit has been made, the amount in the scheme is £315.25.

(b) Find the amount in the scheme at the start of the fortieth year, after the annual deposit has been made.

[E]

Solution:

(a) Start of year 1 = £100

End of year 1 = 100×1.05

Start of year 2 = $(100 \times 1.05 + 100)$

End of year 2 = $(100 \times 1.05 + 100) \times 1.05 = 100 \times 1.05^2 + 100 \times 1.05$

Start of year 3 = $100 \times 1.05^2 + 100 \times 1.05 + 100 = 110.25 + 105 + 100 = \text{£ } 315.25$

(b) Amount at start of year 40

$= 100 \times 1.05^{39} + 100 \times 1.05^{38} + \dots + 100 \times 1.05 + 100$

$= 100 \times \underbrace{(1.05^{39} + 1.05^{38} + \dots + 1.05 + 1)}$

A geometric series with $a = 1$, $r = 1.05$ and $n = 40$.

$$\text{Use } S_n = \frac{a(r^n - 1)}{r - 1}$$

Amount at start of year 40

$$= 100 \times \frac{1(1.05^{40} - 1)}{1.05 - 1}$$

$= \text{£ } 12\,079.98$

Solutionbank C2

Edexcel Modular Mathematics for AS and A-Level

Geometric sequences and series

Exercise F, Question 13

Question:

A competitor is running in a 25 km race. For the first 15 km, she runs at a steady rate of 12 km h^{-1} . After completing 15 km, she slows down and it is now observed that she takes 20% longer to complete each kilometre than she took to complete the previous kilometre.

(a) Find the time, in hours and minutes, the competitor takes to complete the first 16 km of the race. The time taken to complete the r th kilometre is u_r hours.

(b) Show that, for $16 \leq r \leq 25$, $u_r = \frac{1}{12} (1.2)^{r-15}$.

(c) Using the answer to (b), or otherwise, find the time, to the nearest minute, that she takes to complete the race.

[E]

Solution:

(a) Using time = $\frac{\text{distance}}{\text{speed}} = \frac{15}{12} = 1.25 \text{ hours} = 1 \text{ hour } 15 \text{ mins}$.

The competitor takes 1 hour 15 mins for the first 15 km.

Time for each km is $\frac{1 \text{ hour } 15 \text{ mins}}{15} = \frac{75}{15} = 5 \text{ mins}$

Time for the 16th km is $5 \times 1.2 = 6 \text{ mins}$

Total time for first 16 km is 1 hour 15 mins + 6 mins = 1 hour 21 mins

(b) Time for the 17th km is $5 \times 1.2 \times 1.2 = 5 \times 1.2^2 \text{ mins}$

Time for the 18th km is $5 \times 1.2^3 \text{ mins}$

Time for the r th km is $5 \times (1.2)^{r-15} \text{ mins} = \frac{5 \times (1.2)^{r-15}}{60} \text{ hours}$

So $u_r = \frac{1}{12} (1.2)^{r-15}$

(c) Consider the 16th to the 25th kilometre.

Total time for this distance

$$= 5 \times 1.2 + 5 \times 1.2^2 + 5 \times 1.2^3 + \dots + 5 \times 1.2^{10}$$

$$= 5 \times \underbrace{(1.2 + 1.2^2 + 1.2^3 + \dots + 1.2^{10})}$$

A geometric series with $a = 1.2$, $r = 1.2$ and $n = 10$.

$$= 5 \times \frac{1.2(1.2^{10} - 1)}{1.2 - 1}$$

$$= 155.75 \text{ mins}$$

$$= 156 \text{ mins (to the nearest minute)}$$

Total time for the race

$$= \text{time for 1st 15 km} + \text{time for last 10 km}$$

$$= 75 + 156$$

$$= 231 \text{ mins}$$

$$= 3 \text{ hours } 51 \text{ mins}$$

Solutionbank C2

Edexcel Modular Mathematics for AS and A-Level

Geometric sequences and series

Exercise F, Question 14

Question:

A liquid is kept in a barrel. At the start of a year the barrel is filled with 160 litres of the liquid. Due to evaporation, at the end of every year the amount of liquid in the barrel is reduced by 15% of its volume at the start of the year.

- (a) Calculate the amount of liquid in the barrel at the end of the first year.
- (b) Show that the amount of liquid in the barrel at the end of ten years is approximately 31.5 litres.
At the start of each year a new barrel is filled with 160 litres of liquid so that, at the end of 20 years, there are 20 barrels containing liquid.
- (c) Calculate the total amount of liquid, to the nearest litre, in the barrels at the end of 20 years.

[E]

Solution:

(a) Liquid at start of year = 160 litres
Liquid at end of year = $160 \times 0.85 = 136$ litres

(b) Liquid at end of year 2 = $160 \times 0.85 \times 0.85 = 160 \times 0.85^2$
 \vdots
 Liquid at end of year 10 = $160 \times 0.85^{10} = 31.499 \dots = 31.5$ litres

(c) Barrel 1 would have 20 years of evaporation. Amount = $160 \times (0.85)^{20}$
 Barrel 2 would have 19 years of evaporation. Amount = $160 \times (0.85)^{19}$
 \vdots

Barrel 20 would have 1 year of evaporation. Amount = $160 \times (0.85)^1$
 Total amount of liquid
 $= 160 \times 0.85^{20} + 160 \times 0.85^{19} + \dots + 160 \times 0.85$
 $= 160 \times \underbrace{(0.85^{20} + 0.85^{19} + \dots + 0.85)}$

A geometric series with $a = 0.85$, $r = 0.85$ and $n = 20$.

$$\text{Use } S_n = \frac{a(1-r^n)}{1-r}$$

Total amount of liquid
 $= 160 \times \frac{0.85(1-0.85^{20})}{1-0.85}$
 $= 871.52$
 $= 872$ litres (to nearest litre)

Solutionbank C2

Edexcel Modular Mathematics for AS and A-Level

Geometric sequences and series

Exercise F, Question 15

Question:

At the beginning of the year 2000 a company bought a new machine for £15 000. Each year the value of the machine decreases by 20% of its value at the start of the year.

- (a) Show that at the start of the year 2002, the value of the machine was £9600.
- (b) When the value of the machine falls below £500, the company will replace it. Find the year in which the machine will be replaced.
- (c) To plan for a replacement machine, the company pays £1000 at the start of each year into a savings account. The account pays interest of 5% per annum. The first payment was made when the machine was first bought and the last payment will be made at the start of the year in which the machine is replaced. Using your answer to part (b), find how much the savings account will be worth when the machine is replaced.

[E]

Solution:

(a) Beginning of 2000 value is £15 000
 Beginning of 2001 value is $15\ 000 \times 0.8$
 Beginning of 2002 value is $15\ 000 \times 0.8 \times 0.8 = \text{£}9600$

(b) Beginning of 2003 value is $15\ 000 \times (0.8)^3$
 After n years it will be worth $15\ 000 \times (0.8)^n$
 Value falls below £500 when
 $15\ 000 \times (0.8)^n < 500$

$$(0.8)^n < \frac{500}{15\ 000}$$

$$(0.8)^n < \frac{1}{30}$$

$$\log (0.8)^n < \log \left(\frac{1}{30} \right)$$

$$n \log \left(0.8 \right) < \log \left(\frac{1}{30} \right)$$

$$n > \frac{\log \left(\frac{1}{30} \right)}{\log (0.8)}$$

$n > 15.24$
 It will be replaced in 2015.

(c) Beginning of 2000 amount in account is £1000
 End of 2000 amount in account is 1000×1.05
 Beginning of 2001 amount in account is $1000 \times 1.05 + 1000$
 End of 2001 amount in account is
 $(1000 \times 1.05 + 1000) \times 1.05 = 1000 \times 1.05^2 + 1000 \times 1.05$
 Beginning of 2002 amount in account is $1000 \times 1.05^2 + 1000 \times 1.05 + 1000$
 ⋮

Beginning of 2015 amount in account

$$\begin{aligned} &= 1000 \times 1.05^{15} + 1000 \times 1.05^{14} + \dots + 1000 \times 1.05 + 1000 \\ &= 1000 \times \underbrace{(1.05^{15} + 1.05^{14} + \dots + 1.05 + 1)} \end{aligned}$$

A geometric series with $a = 1$, $r = 1.05$ and $n = 16$.

$$\text{Use } S_n = \frac{a(r^n - 1)}{r - 1}$$

Beginning of 2015 amount in account

$$= 1000 \times \frac{1(1.05^{16} - 1)}{1.05 - 1}$$

$$= \text{£}23\,657.49$$

© Pearson Education Ltd 2008

Solutionbank C2

Edexcel Modular Mathematics for AS and A-Level

Geometric sequences and series

Exercise F, Question 16

Question:

A mortgage is taken out for £80 000. It is to be paid by annual instalments of £5000 with the first payment being made at the end of the first year that the mortgage was taken out. Interest of 4% is then charged on any outstanding debt. Find the total time taken to pay off the mortgage.

Solution:

Mortgage = £ 80 000

Debt at end of year 1 = (80 000 - 5000)

Debt at start of year 2 = (80 000 - 5000) × 1.04

Debt at end of year 2

$$= (80 000 - 5000) \times 1.04 - 5000$$

$$= 80 000 \times 1.04 - 5000 \times 1.04 - 5000$$

Debt at start of year 3

$$= (80 000 \times 1.04 - 5000 \times 1.04 - 5000) \times 1.04$$

$$= 80 000 \times 1.04^2 - 5000 \times 1.04^2 - 5000 \times 1.04$$

$$\text{Debt at end of year 3} = 80 000 \times 1.04^2 - 5000 \times 1.04^2 - 5000 \times 1.04 - 5000$$

⋮

Debt at end of year n

$$= 80 000 \times 1.04^{n-1} - 5000 \times 1.04^{n-1} - 5000 \times 1.04^{n-2} - \dots - 5000 \times 1.04 - 5000$$

Mortgage is paid off when this is zero.

$$\Rightarrow 80 000 \times 1.04^{n-1} - 5000 \times 1.04^{n-1} - 5000 \times 1.04^{n-2} - \dots - 5000 = 0$$

$$\Rightarrow 80 000 \times 1.04^{n-1} = 5000 \times 1.04^{n-1} + 5000 \times 1.04^{n-2} + \dots + 5000$$

$$\Rightarrow 80 000 \times 1.04^{n-1} = 5000 \underbrace{(1.04^{n-1} + 1.04^{n-2} + \dots + 1)}$$

A geometric series with $a = 1$, $r = 1.04$ and n terms.

$$\text{Use } S_n = \frac{a(r^n - 1)}{r - 1}$$

$$80 000 \times 1.04^{n-1} = 5000 \times \frac{1(1.04^n - 1)}{1.04 - 1}$$

$$80 000 \times 1.04^{n-1} = 125 000 (1.04^n - 1)$$

$$80 000 \times 1.04^{n-1} = 125 000 \times 1.04^n - 125 000$$

$$80 000 \times 1.04^{n-1} = 125 000 \times 1.04 \times 1.04^{n-1} - 125 000$$

$$80 000 \times 1.04^{n-1} = 130 000 \times 1.04^{n-1} - 125 000$$

$$125 000 = 50 000 \times 1.04^{n-1}$$

$$\frac{125 000}{50 000} = 1.04^{n-1}$$

$$\frac{5}{2} = 1.04^{n-1}$$

$$\log \left(\frac{5}{2} \right) = \log (1.04)^{n-1}$$

$$\log \left(\frac{5}{2} \right) = (n-1) \log 1.04$$

$$\frac{\log \left(\frac{5}{2} \right)}{\log 1.04} = n - 1$$

$$23.36 = n - 1$$

$$24.36 = n$$

It takes 25 years to pay off the mortgage.

© Pearson Education Ltd 2008

Solutionbank C2

Edexcel Modular Mathematics for AS and A-Level

Graphics of trigonometric functions

Exercise A, Question 1

Question:

Draw diagrams, as in Examples 1 and 2, to show the following angles. Mark in the acute angle that OP makes with the x -axis.

(a) -80°

(b) 100°

(c) 200°

(d) 165°

(e) -145°

(f) 225°

(g) 280°

(h) 330°

(i) -160°

(j) -280°

(k) $\frac{3\pi}{4}$

(l) $\frac{7\pi}{6}$

(m) $-\frac{5\pi}{3}$

(n) $-\frac{5\pi}{8}$

(o) $\frac{19\pi}{9}$

Solution:

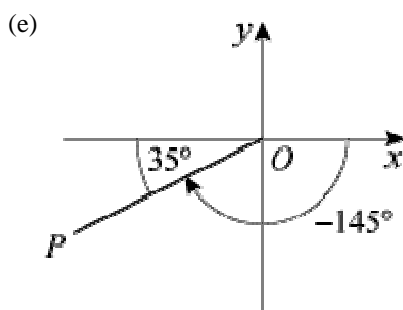
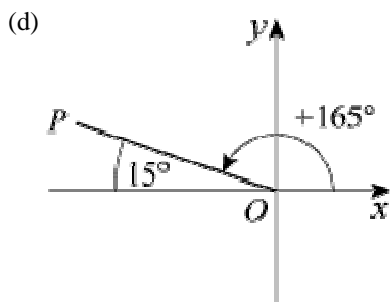
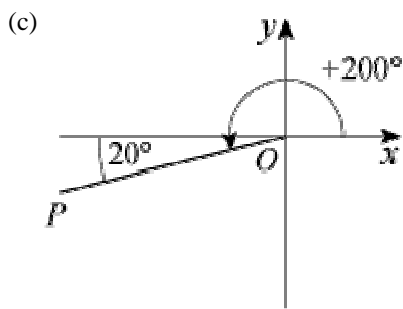
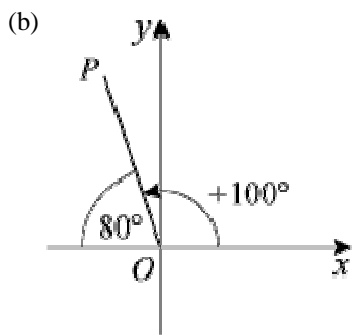
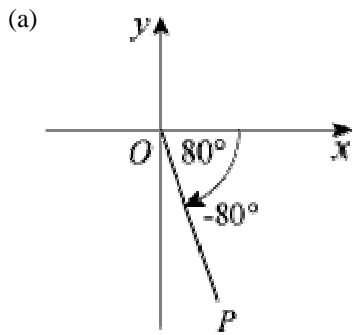

(f)

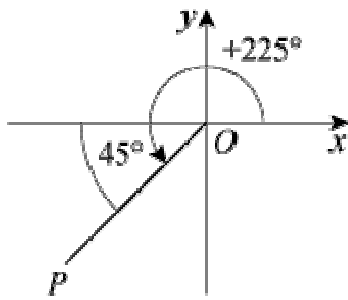

(g)

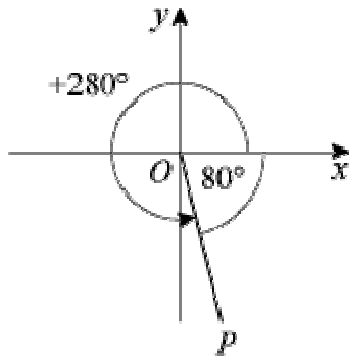

(h)

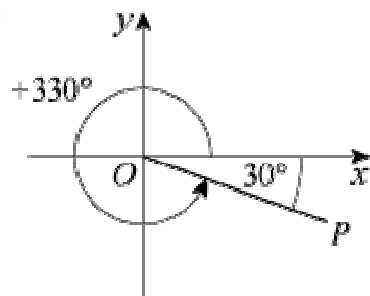

(i)

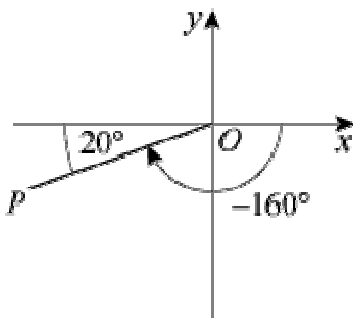

(j)

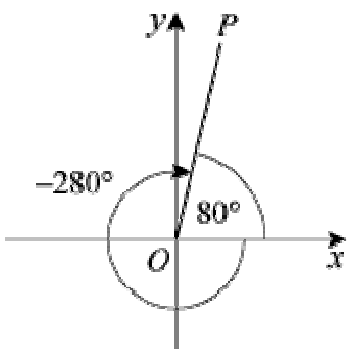

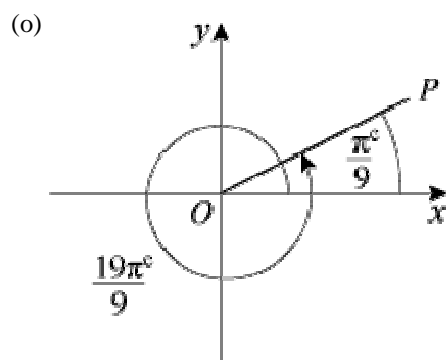
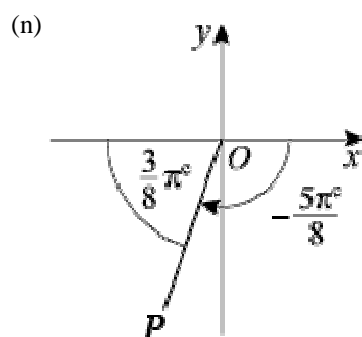
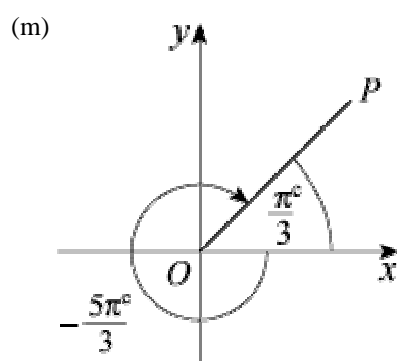
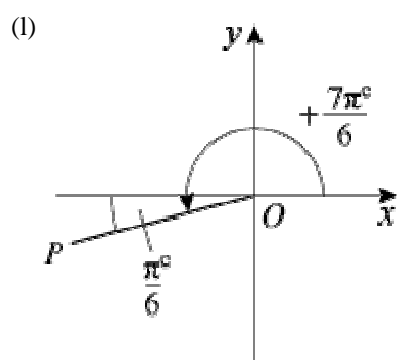
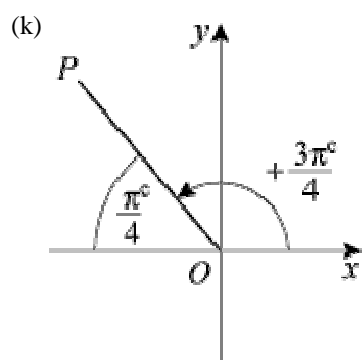

© Pearson Education Ltd 2008

Solutionbank C2

Edexcel Modular Mathematics for AS and A-Level

Graphics of trigonometric functions

Exercise A, Question 2

Question:

State the quadrant that OP lies in when the angle that OP makes with the positive x -axis is:

(a) 400°

(b) 115°

(c) -210°

(d) 255°

(e) -100°

(f) $\frac{7\pi}{8}$

(g) $-\frac{11\pi}{6}$

(h) $\frac{13\pi}{7}$

Solution:

(a)

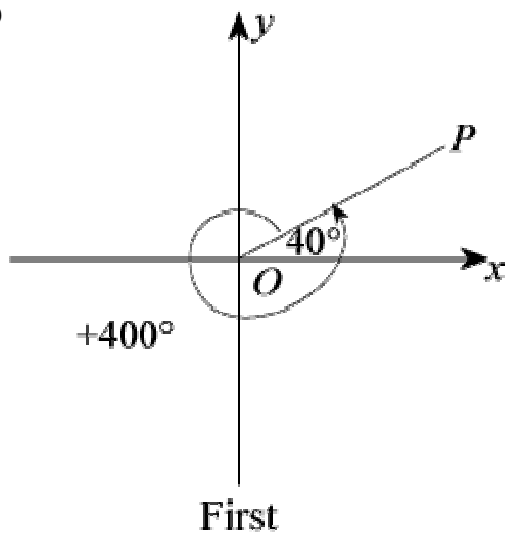

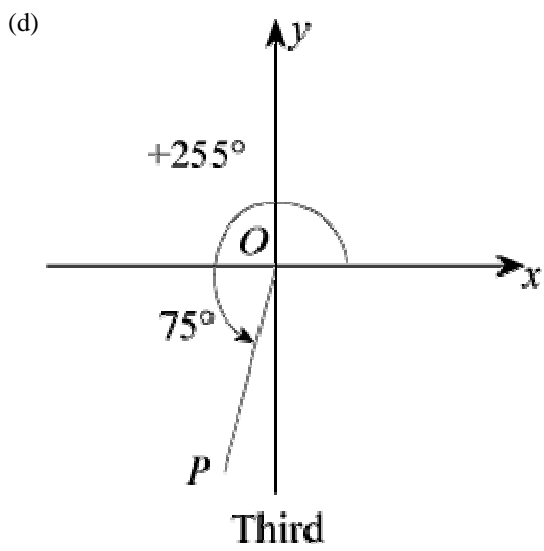
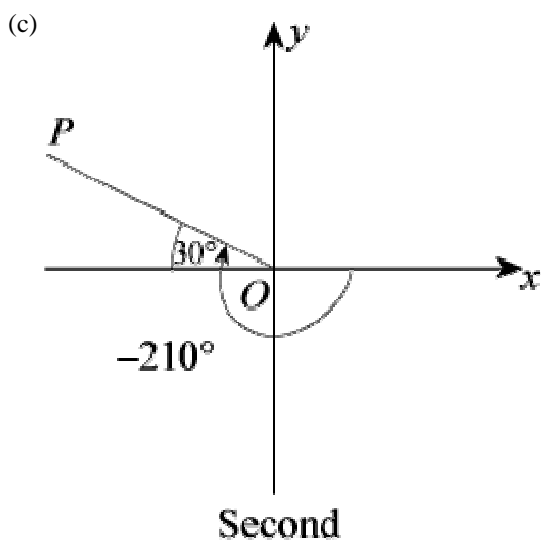
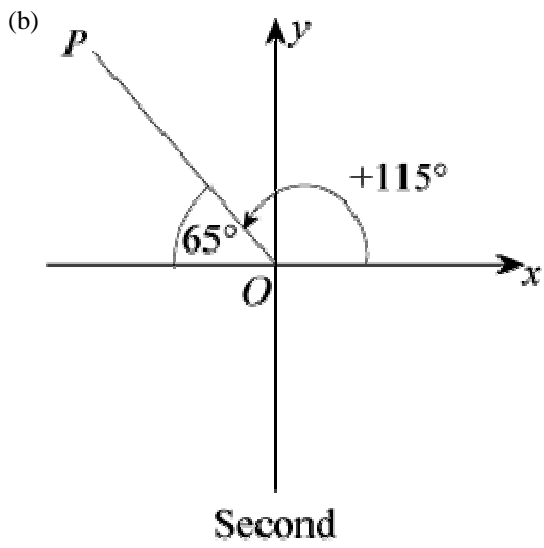

(e)

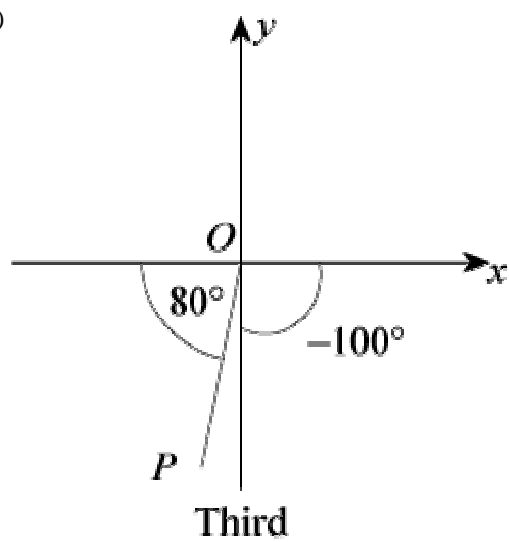

(f)

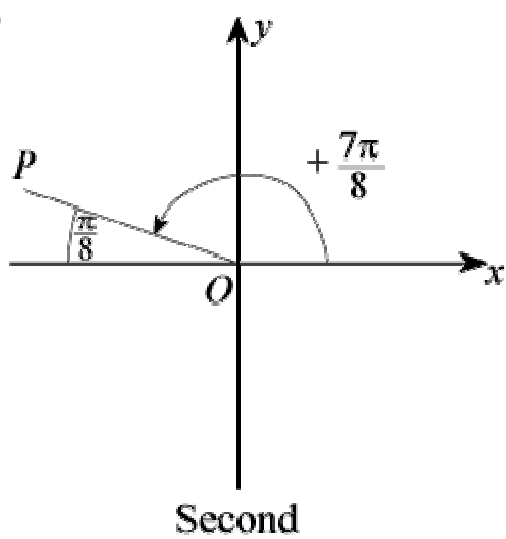

(g)

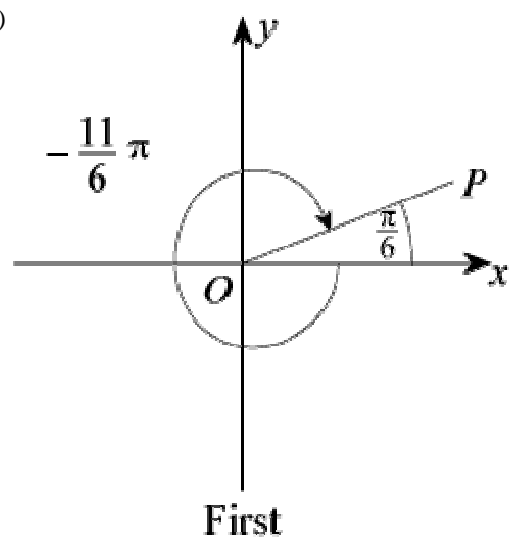

(h)

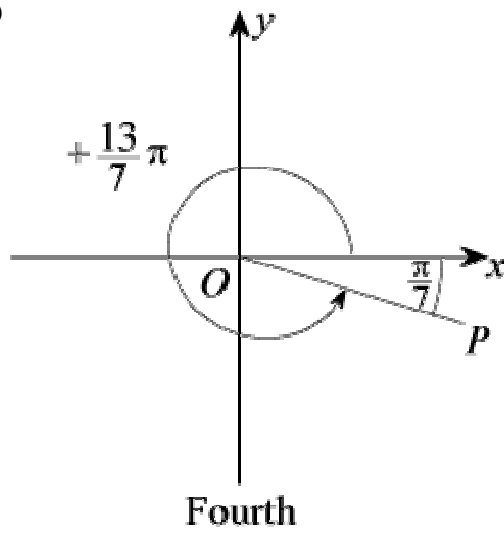

© Pearson Education Ltd 2008

Solutionbank C2

Edexcel Modular Mathematics for AS and A-Level

Graphics of trigonometric functions

Exercise B, Question 1

Question:

(Note: do not use a calculator.)

Write down the values of:

(a) $\sin (-90)^\circ$

(b) $\sin 450^\circ$

(c) $\sin 540^\circ$

(d) $\sin (-450)^\circ$

(e) $\cos (-180)^\circ$

(f) $\cos (-270)^\circ$

(g) $\cos 270^\circ$

(h) $\cos 810^\circ$

(i) $\tan 360^\circ$

(j) $\tan (-180)^\circ$

Solution:

(a)

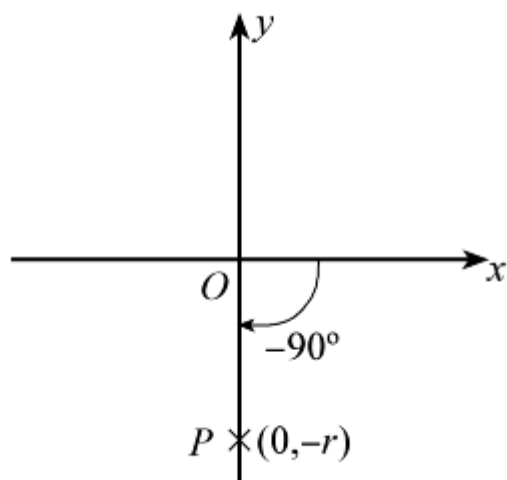

$$\sin \left(-90 \right)^\circ = \frac{-r}{r} = -1$$

(b)

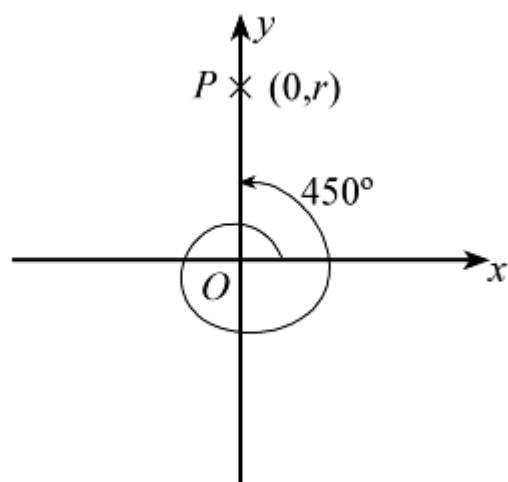

$$\sin 450^\circ = \frac{r}{r} = 1$$

(c)

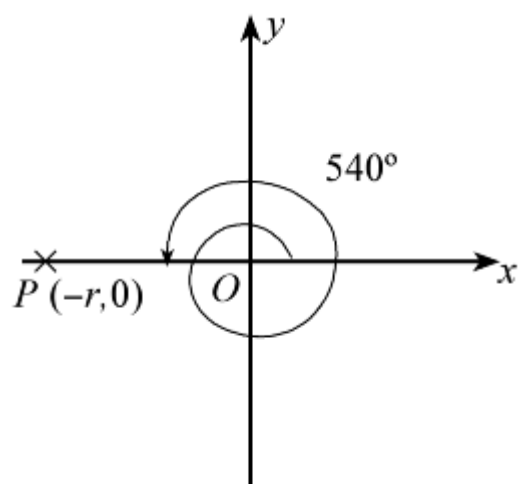

$$\sin 540^\circ = \frac{0}{r} = 0$$

(d)

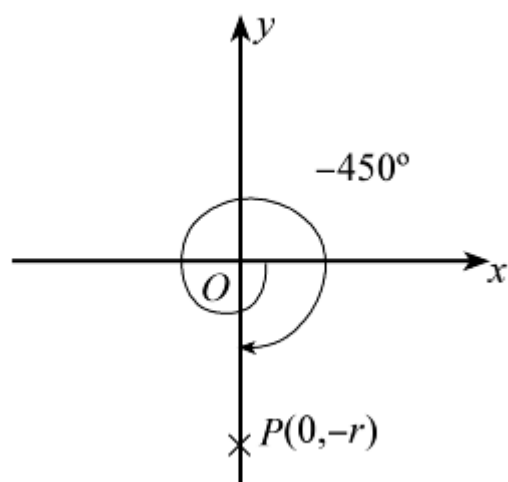

$$\sin \left(-450 \right)^\circ = \frac{-r}{r} = -1$$

(e)

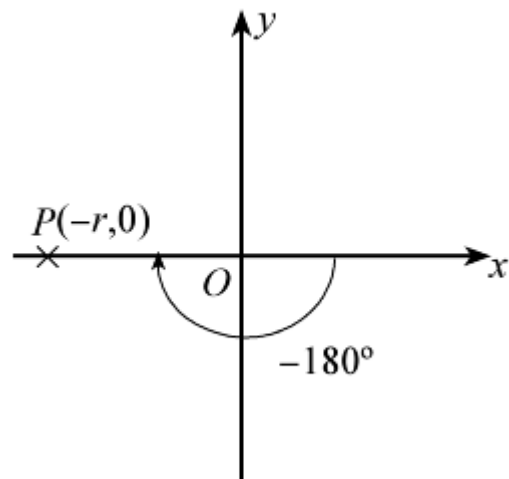

$$\cos \left(-180 \right)^\circ = \frac{-r}{r} = -1$$

(f)

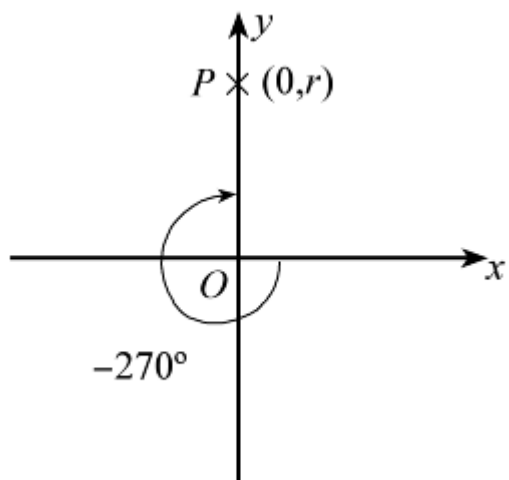

$$\cos \left(-270 \right)^\circ = \frac{0}{r} = 0$$

(g)

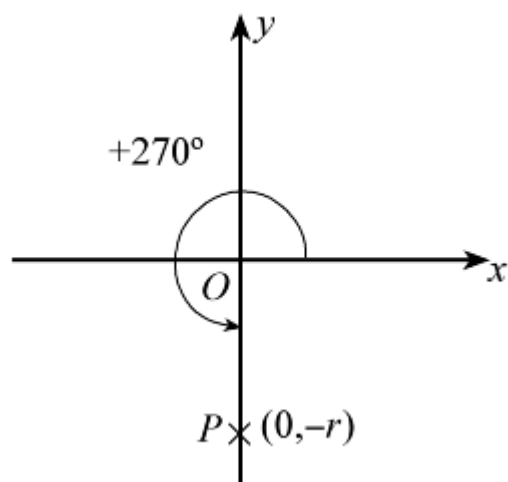

$$\cos 270^\circ = \frac{0}{r} = 0$$

(h)

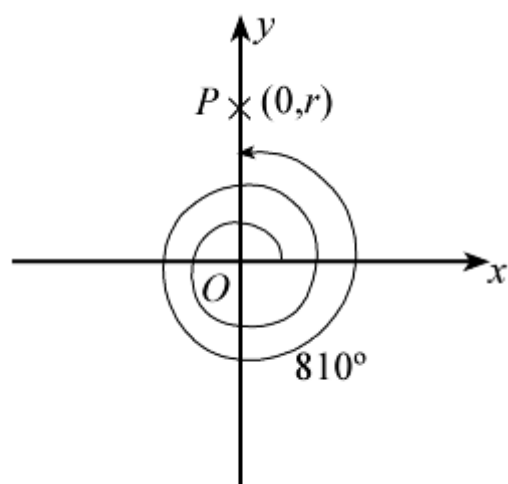

$$\cos 810^\circ = \frac{0}{r} = 0$$

(i)

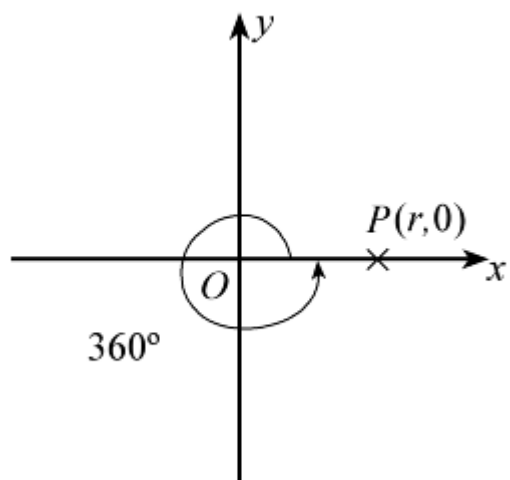

$$\tan 360^\circ = \frac{0}{r} = 0$$

(j)

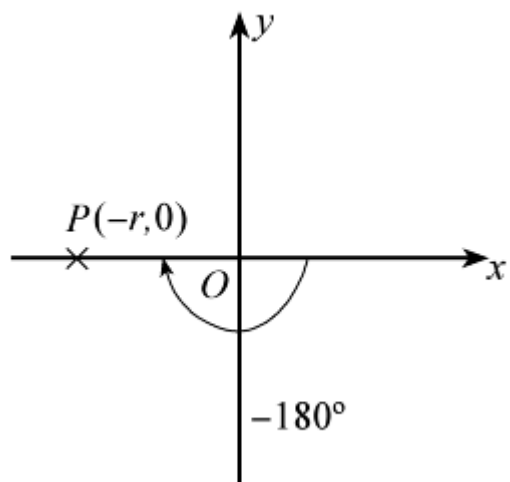

$$\tan \left(-180 \right)^\circ = \frac{0}{-r} = 0$$

© Pearson Education Ltd 2008

Solutionbank C2

Edexcel Modular Mathematics for AS and A-Level

Graphics of trigonometric functions

Exercise B, Question 2

Question:

(Note: do not use a calculator.)

Write down the values of the following, where the angles are in radians:

(a) $\sin \frac{3\pi}{2}$

(b) $\sin \left(-\frac{\pi}{2} \right)$

(c) $\sin 3\pi$

(d) $\sin \frac{7\pi}{2}$

(e) $\cos 0$

(f) $\cos \pi$

(g) $\cos \frac{3\pi}{2}$

(h) $\cos \left(-\frac{3\pi}{2} \right)$

(i) $\tan \pi$

(j) $\tan (-2\pi)$

Solution:

(a)

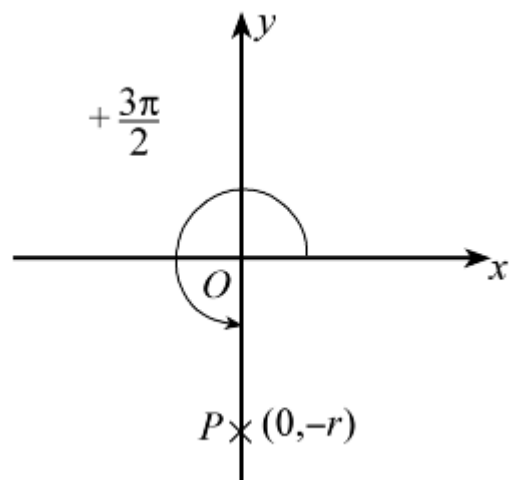

$$\sin \frac{3\pi}{2} = \frac{-r}{r} = -1$$

(b)

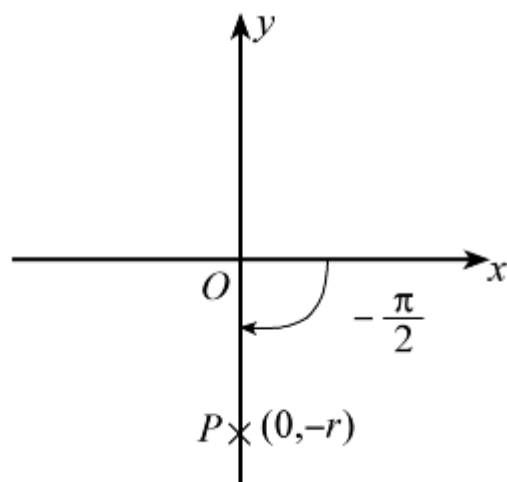

$$\sin \left(\frac{-\pi}{2} \right) = \frac{-r}{r} = -1$$

(c)

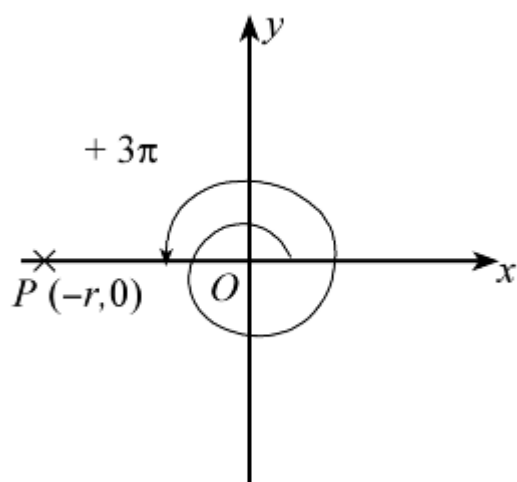

$$\sin 3\pi = \frac{0}{r} = 0$$

(d)

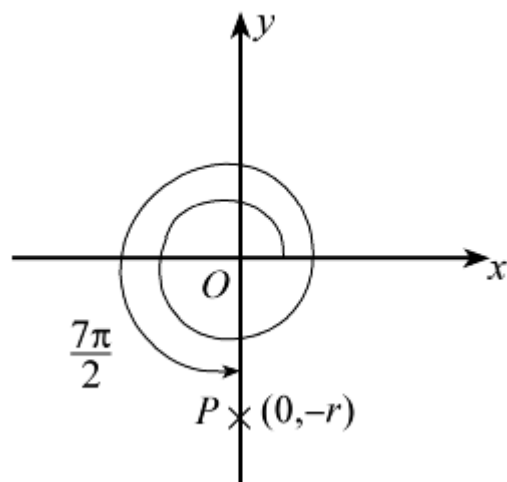

$$\sin \frac{7\pi}{2} = \frac{-r}{r} = -1$$

(e)

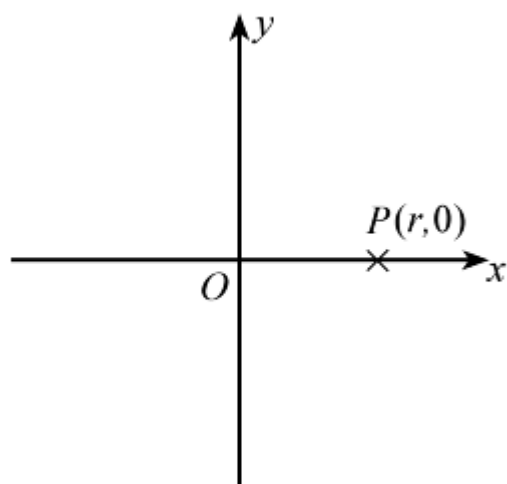

$$\cos 0^\circ = \frac{r}{r} = 1$$

(f)

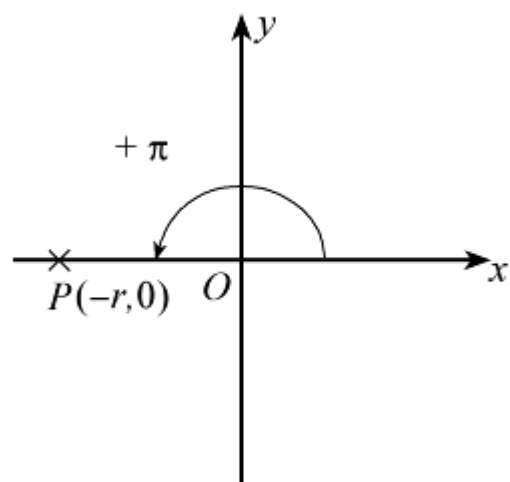

$$\cos \pi = \frac{-r}{r} = -1$$

(g)

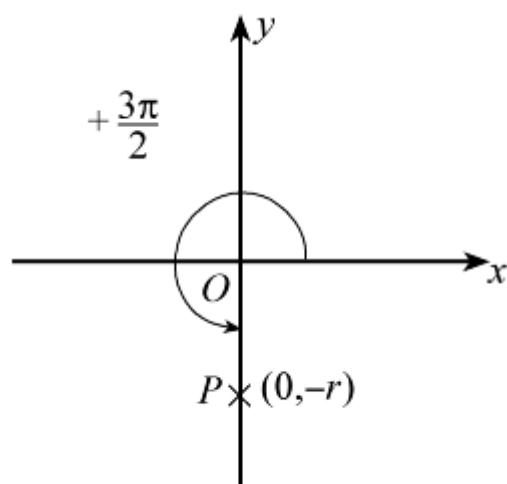

$$\cos \frac{3\pi}{2} = \frac{0}{r} = 0$$

(h)

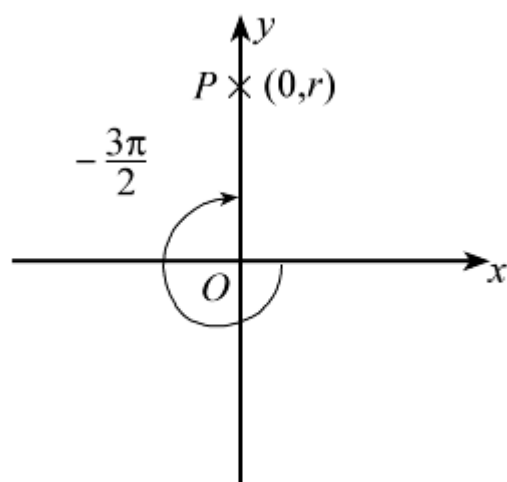

$$\cos \left(-\frac{3\pi}{2} \right) = \frac{0}{r} = 0$$

(i)

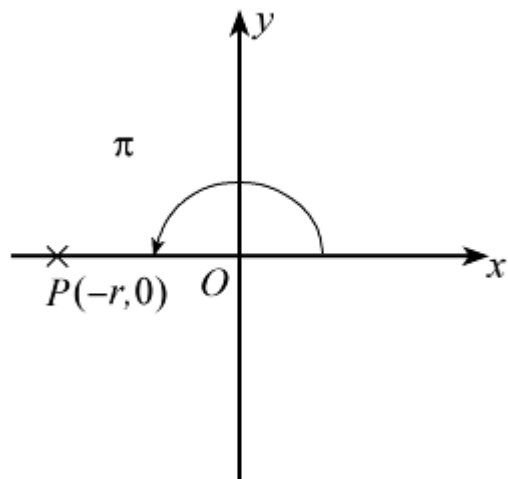

$$\tan \pi = \frac{0}{-r} = 0$$

(j)

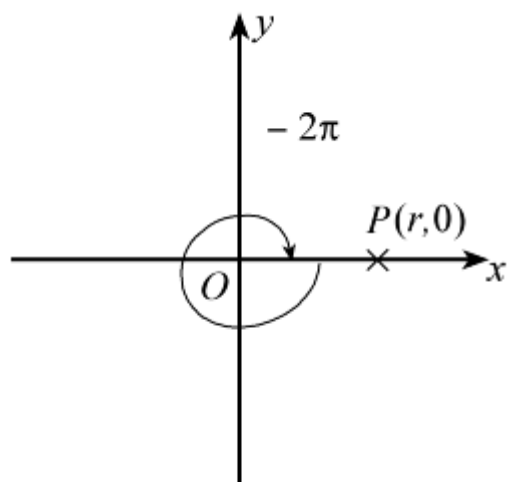

$$\tan \left(-2\pi \right) = \frac{0}{r} = 0$$

Solutionbank C2

Edexcel Modular Mathematics for AS and A-Level

Graphics of trigonometric functions

Exercise C, Question 1

Question:

(Note: Do not use a calculator.)

By drawing diagrams, as in Example 6, express the following in terms of trigonometric ratios of acute angles:

(a) $\sin 240^\circ$

(b) $\sin (-80)^\circ$

(c) $\sin (-200)^\circ$

(d) $\sin 300^\circ$

(e) $\sin 460^\circ$

(f) $\cos 110^\circ$

(g) $\cos 260^\circ$

(h) $\cos (-50)^\circ$

(i) $\cos (-200)^\circ$

(j) $\cos 545^\circ$

(k) $\tan 100^\circ$

(l) $\tan 325^\circ$

(m) $\tan (-30)^\circ$

(n) $\tan (-175)^\circ$

(o) $\tan 600^\circ$

(p) $\sin \frac{7\pi}{6}$

(q) $\cos \frac{4\pi}{3}$

(r) $\cos \left(-\frac{3\pi}{4} \right)$

(s) $\tan \frac{7\pi}{5}$

(t) $\tan \left(-\frac{\pi}{3} \right)$

(u) $\sin \frac{15\pi}{16}$

(v) $\cos \frac{8\pi}{5}$

(w) $\sin \left(-\frac{6\pi}{7} \right)$

(x) $\tan \frac{15\pi}{8}$

Solution:

(a)

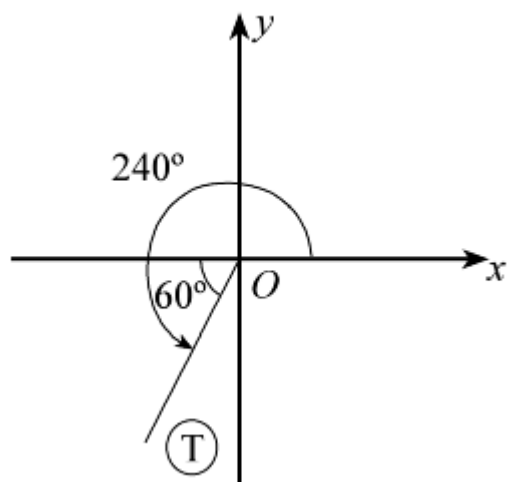

60° is the acute angle.
 In third quadrant sin is - ve.
 So $\sin 240^\circ = -\sin 60^\circ$

(b)

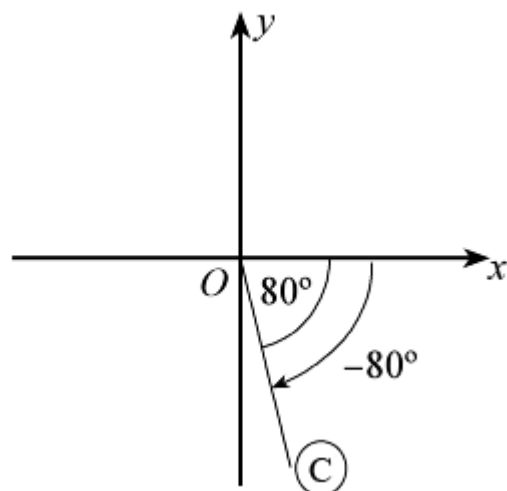

80° is the acute angle.

In fourth quadrant sin is -ve.
So $\sin (-80)^\circ = -\sin 80^\circ$

(c)

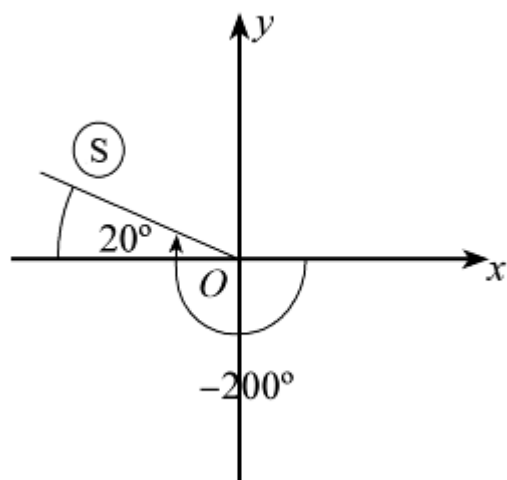

20° is the acute angle.
In second quadrant sin is +ve.
So $\sin (-200)^\circ = +\sin 20^\circ$

(d)

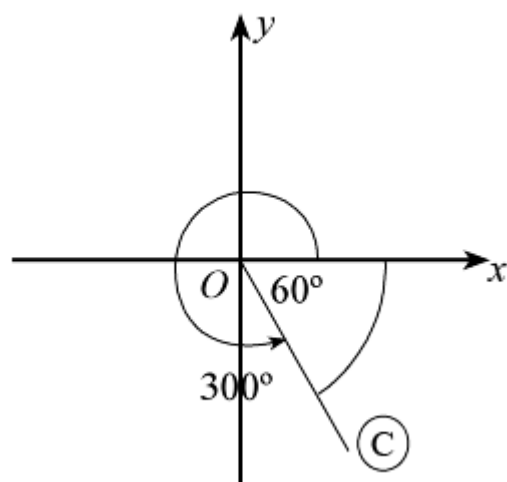

60° is the acute angle.
In fourth quadrant sin is -ve.
So $\sin 300^\circ = -\sin 60^\circ$

(e)

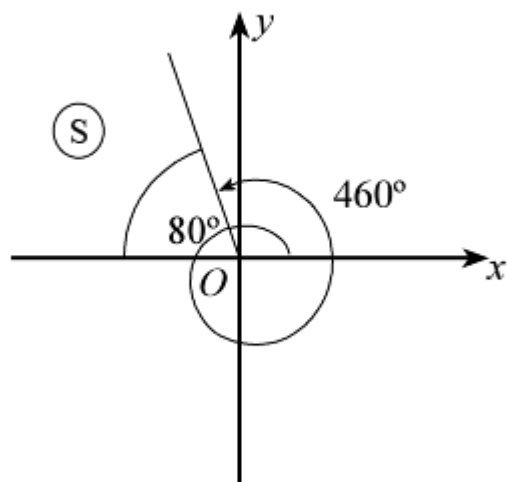

80° is the acute angle.
 In second quadrant sin is +ve.
 So $\sin 460^\circ = +\sin 80^\circ$

(f)

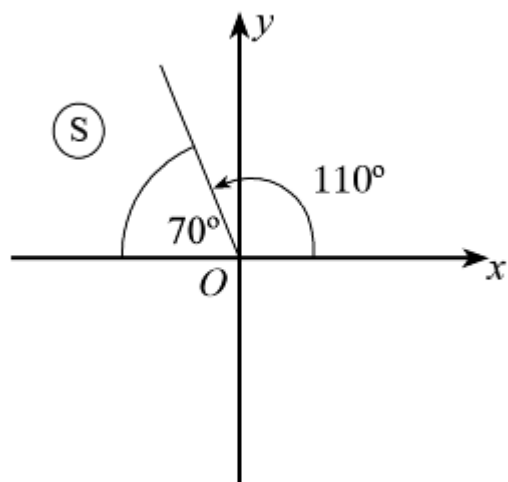

70° is the acute angle.
 In second quadrant cos is -ve.
 So $\cos 110^\circ = -\cos 70^\circ$

(g)

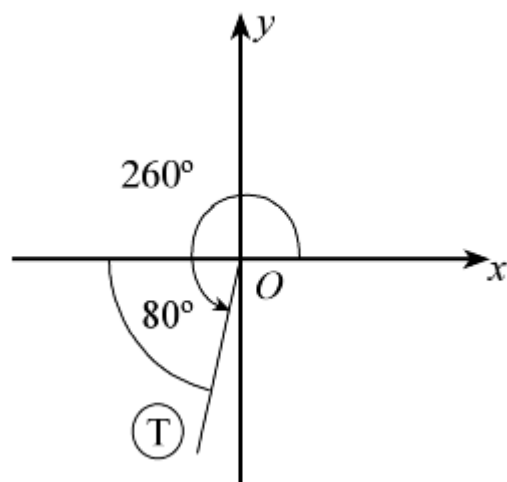

80° is the acute angle.
 In third quadrant cos is - ve.
 So $\cos 260^\circ = -\cos 80^\circ$

(h)

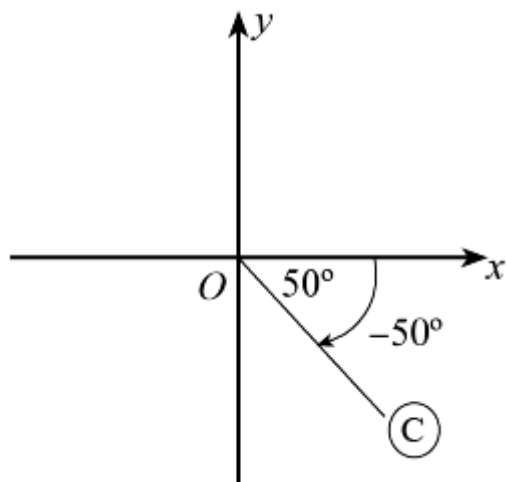

50° is the acute angle.
 In fourth quadrant cos is +ve.
 So $\cos (-50)^\circ = +\cos 50^\circ$

(i)

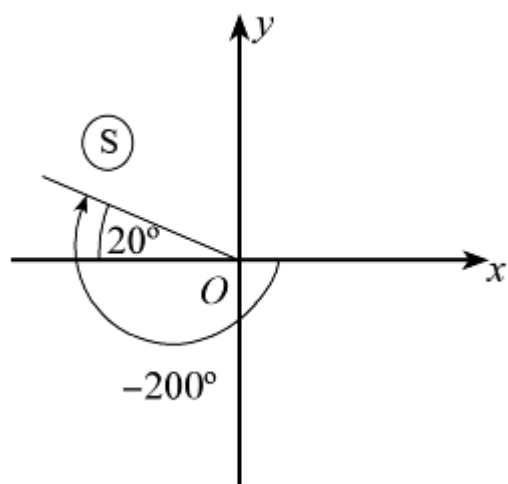

20° is the acute angle.
 In second quadrant cos is - ve.
 So $\cos (-200)^\circ = -\cos 20^\circ$

(j)

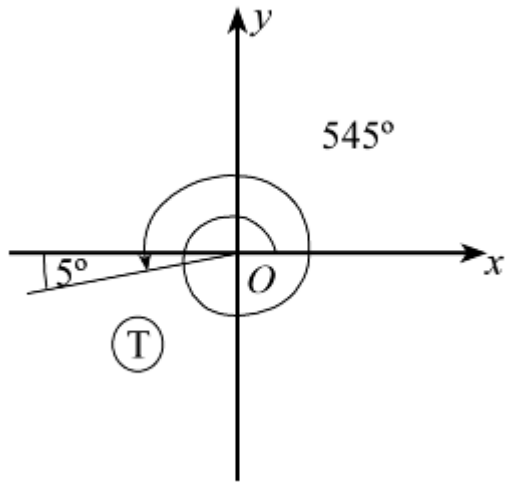

5° is the acute angle.
 In third quadrant cos is - ve.
 So $\cos 545^\circ = -\cos 5^\circ$

(k)

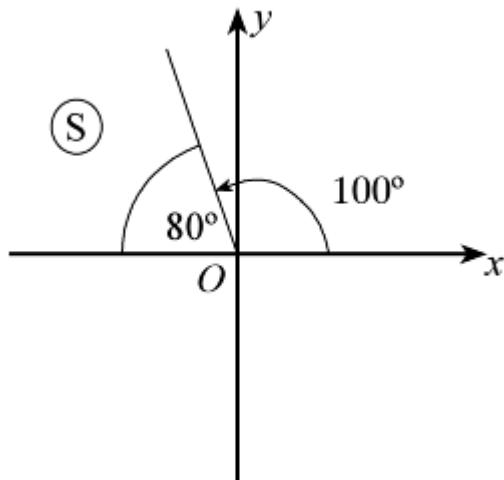

80° is the acute angle.
 In second quadrant tan is - ve.
 So $\tan 100^\circ = -\tan 80^\circ$

(l)

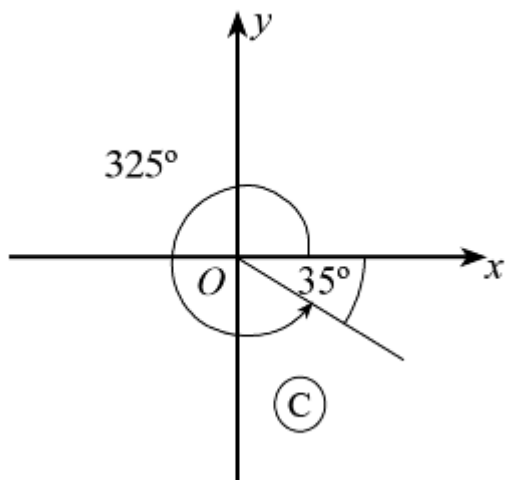

35° is the acute angle.

In fourth quadrant tan is - ve.

So $\tan 325^\circ = -\tan 35^\circ$

(m)

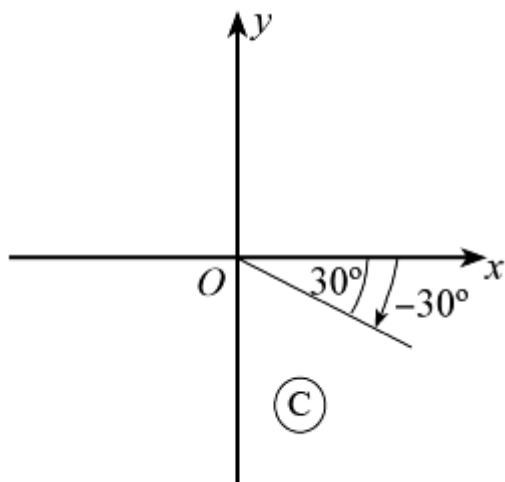

30° is the acute angle.

In fourth quadrant tan is - ve.

So $\tan (-30)^\circ = -\tan 30^\circ$

(n)

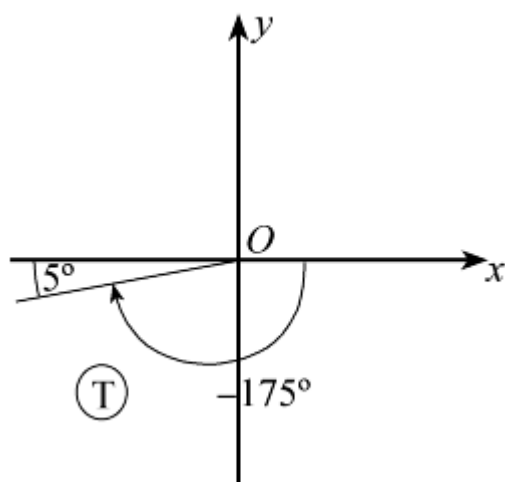

5° is the acute angle.

In third quadrant tan is +ve.

So $\tan (-175)^\circ = +\tan 5^\circ$

(o)

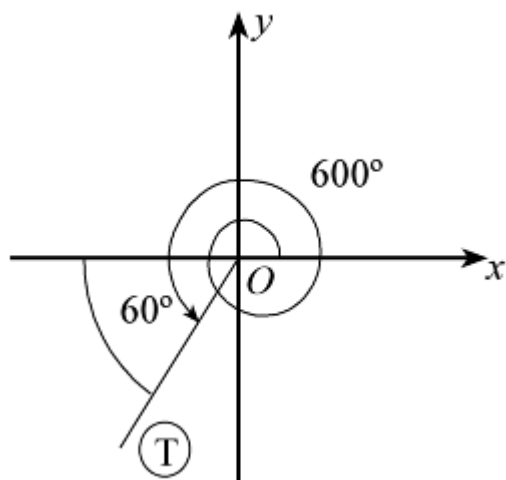

60° is the acute angle.
 In third quadrant tan is +ve.
 So $\tan 600^\circ = +\tan 60^\circ$

(p)

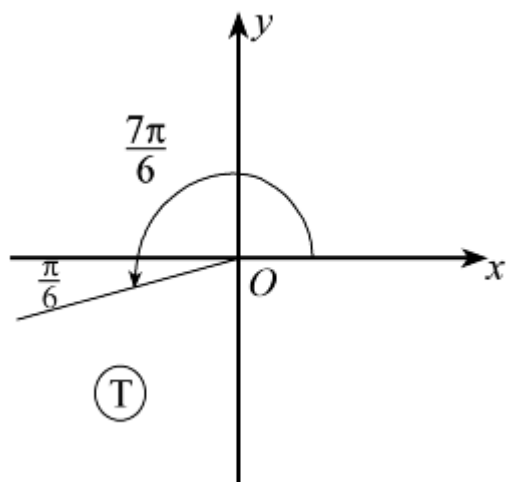

$\frac{\pi}{6}$ is the acute angle.
 In third quadrant sin is -ve.
 So $\sin \frac{7\pi}{6} = -\sin \frac{\pi}{6}$

(q)

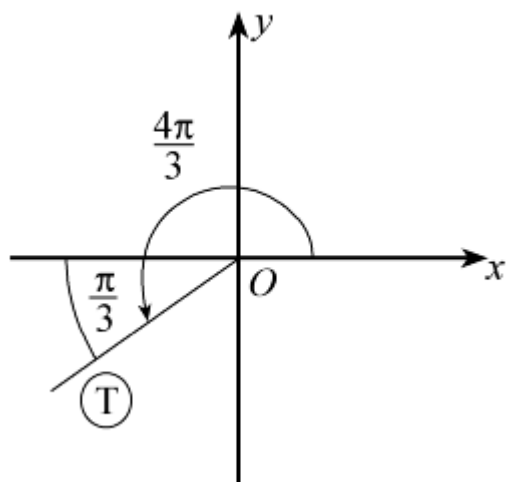

$\frac{\pi}{3}$ is the acute angle.

In third quadrant cos is - ve.

$$\text{So } \cos \frac{4\pi}{3} = -\cos \frac{\pi}{3}$$

(r)

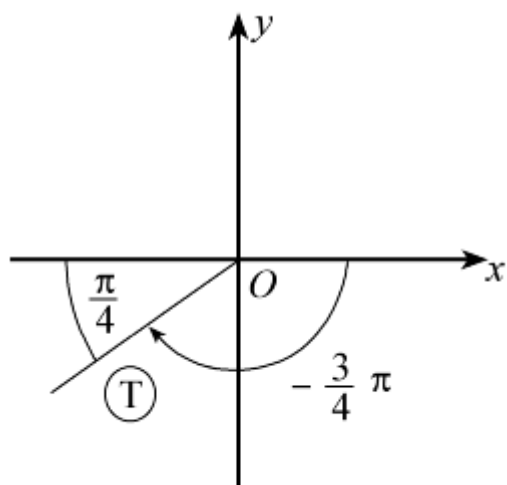

$\frac{\pi}{4}$ is the acute angle.

In third quadrant cos is - ve.

$$\text{So } \cos \left(-\frac{3}{4}\pi \right) = -\cos \frac{\pi}{4}$$

(s)

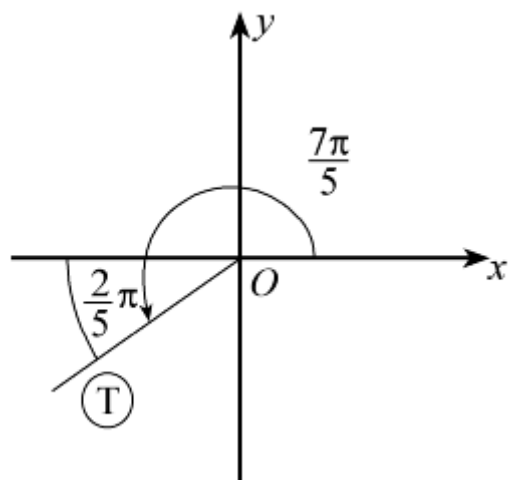

$\frac{2\pi}{5}$ is the acute angle.

In third quadrant tan is +ve.

$$\text{So } \tan \frac{7\pi}{5} = + \tan \frac{2\pi}{5}$$

(t)

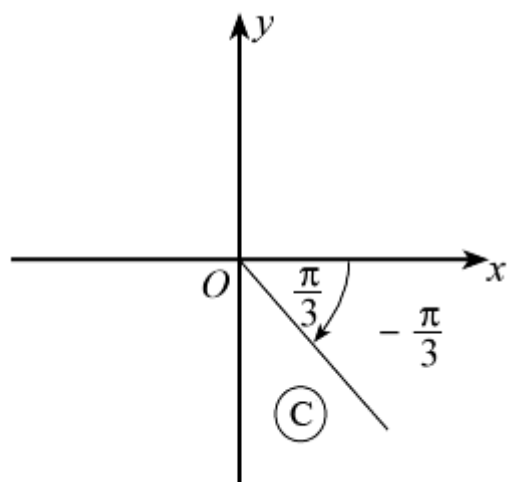

$\frac{\pi}{3}$ is the acute angle.

In fourth quadrant tan is - ve.

$$\text{So } \tan \left(-\frac{\pi}{3} \right) = - \tan \frac{\pi}{3}$$

(u)

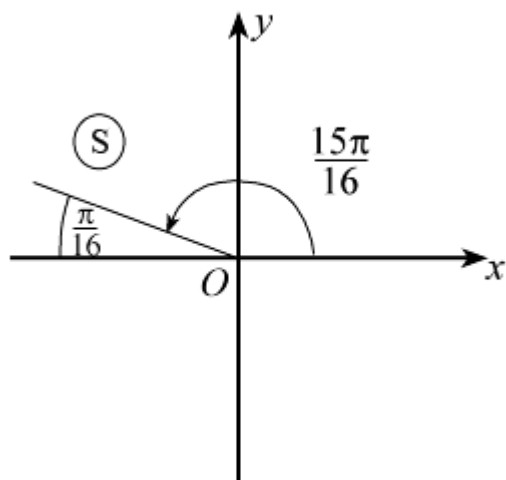

$\frac{\pi}{16}$ is the acute angle.

In second quadrant sin is +ve.

$$\text{So } \sin \frac{15\pi}{16} = + \sin \frac{\pi}{16}$$

(v)

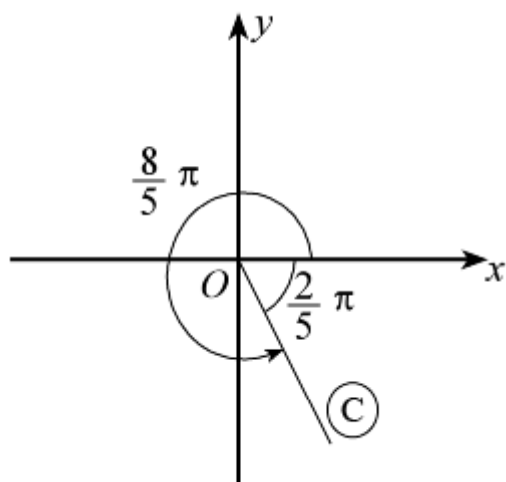

$\frac{2}{5}\pi$ is the acute angle.

In fourth quadrant cos is +ve.

$$\text{So } \cos \frac{8}{5}\pi = + \cos \frac{2}{5}\pi$$

(w)

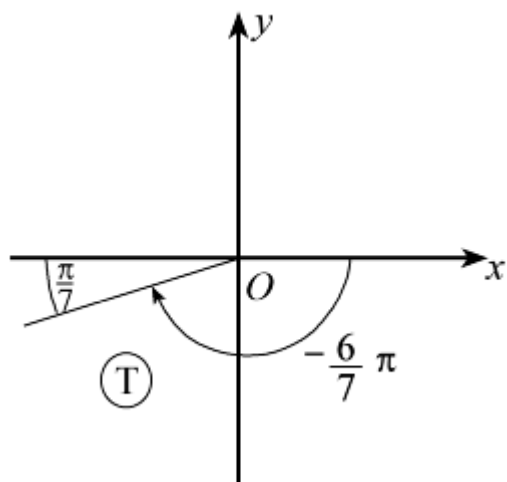

$\frac{\pi}{7}$ is the acute angle.

In third quadrant sin is - ve.

$$\text{So } \sin \left(-\frac{6\pi}{7} \right) = -\sin \frac{\pi}{7}$$

(x)

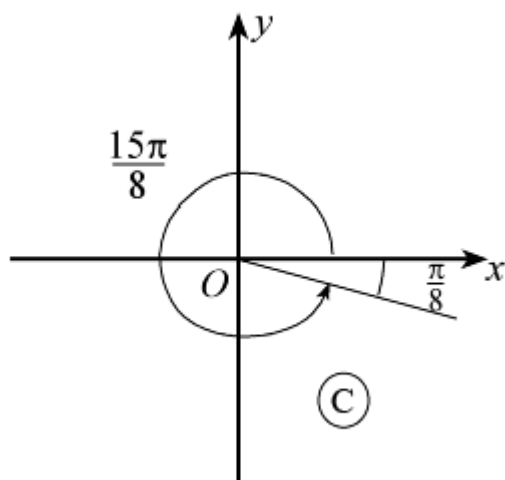

$\frac{\pi}{8}$ is the acute angle.

In fourth quadrant tan is - ve.

$$\text{So } \tan \frac{15\pi}{8} = -\tan \frac{\pi}{8}$$

© Pearson Education Ltd 2008

Solutionbank C2

Edexcel Modular Mathematics for AS and A-Level

Graphics of trigonometric functions

Exercise C, Question 2

Question:

(Note: Do not use a calculator.)

Given that θ is an acute angle measured in degrees, express in terms of $\sin \theta$:

- (a) $\sin (-\theta)$
- (b) $\sin (180^\circ + \theta)$
- (c) $\sin (360^\circ - \theta)$
- (d) $\sin -(180^\circ + \theta)$
- (e) $\sin (-180^\circ + \theta)$
- (f) $\sin (-360^\circ + \theta)$
- (g) $\sin (540^\circ + \theta)$
- (h) $\sin (720^\circ - \theta)$
- (i) $\sin (\theta + 720^\circ)$

Solution:

(a)

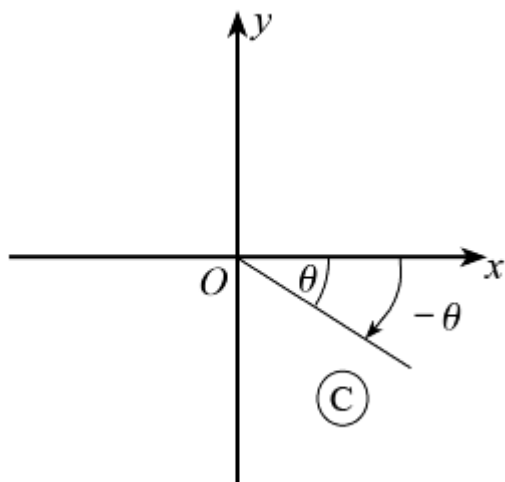

\sin is $-ve$ in this quadrant.
So $\sin (-\theta) = -\sin \theta$

(b)

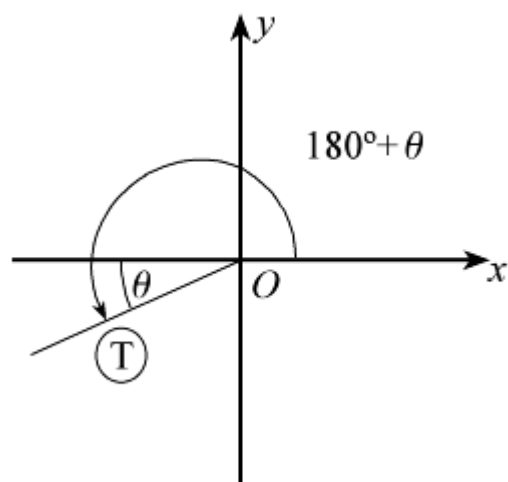

sin is -ve in this quadrant.

$$\text{So } \sin (180^\circ + \theta) = -\sin \theta$$

(c)

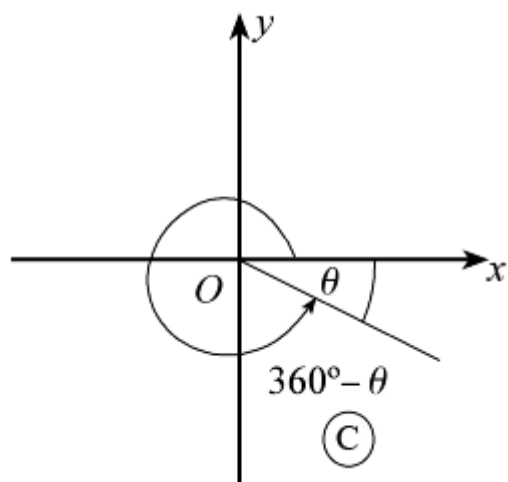

sin is -ve in this quadrant.

$$\text{So } \sin (360^\circ - \theta) = -\sin \theta$$

(d)

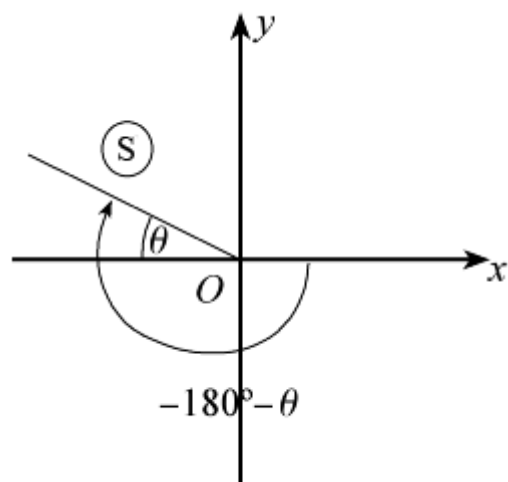

sin is +ve in this quadrant.

$$\text{So } \sin - (180^\circ + \theta) = +\sin \theta$$

(e)

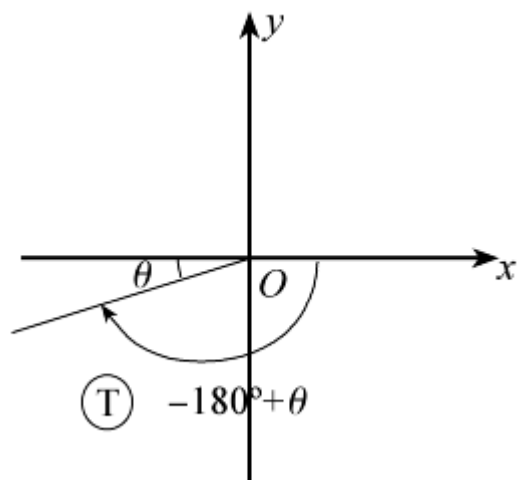

sin is -ve in this quadrant.

So $\sin (-180^\circ + \theta) = -\sin \theta$

(f)

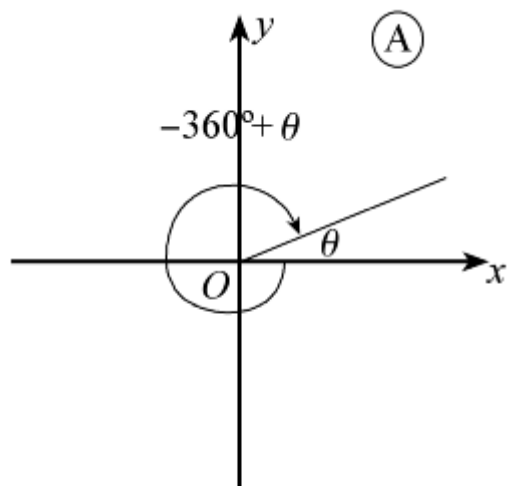

sin is +ve in this quadrant.

So $\sin (-360^\circ + \theta) = +\sin \theta$

(g)

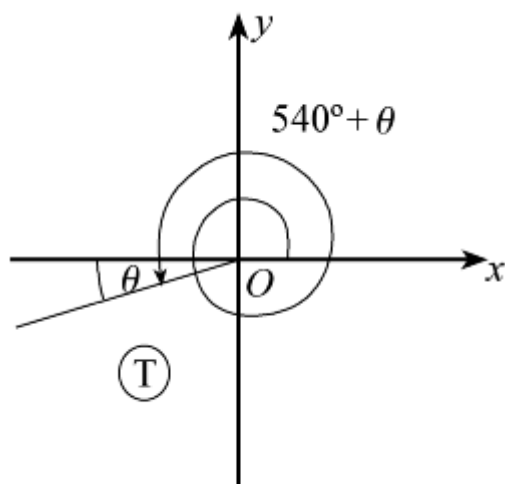

sin is -ve in this quadrant.

So $\sin (540^\circ + \theta) = -\sin \theta$

(h)

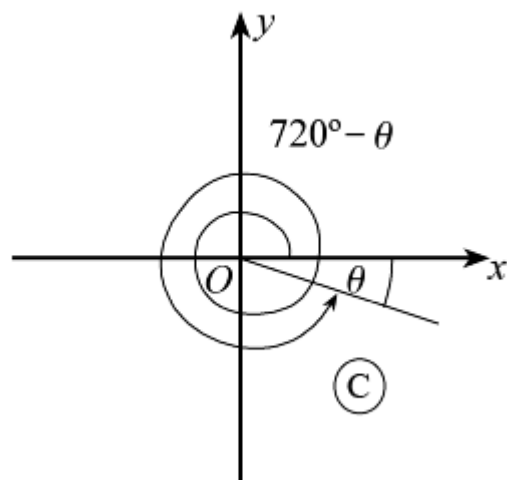

\sin is -ve in this quadrant.

$$\text{So } \sin (720^\circ - \theta) = -\sin \theta$$

(i) $\theta + 720^\circ$ is in the first quadrant with θ to the horizontal.

$$\text{So } \sin (\theta + 720^\circ) = +\sin \theta$$

© Pearson Education Ltd 2008

Solutionbank C2

Edexcel Modular Mathematics for AS and A-Level

Graphics of trigonometric functions

Exercise C, Question 3

Question:

(Note: Do not use a calculator.)

Given that θ is an acute angle measured in degrees, express in terms of $\cos \theta$ or $\tan \theta$:

(a) $\cos (180^\circ - \theta)$

(b) $\cos (180^\circ + \theta)$

(c) $\cos (-\theta)$

(d) $\cos -(180^\circ - \theta)$

(e) $\cos (\theta - 360^\circ)$

(f) $\cos (\theta - 540^\circ)$

(g) $\tan (-\theta)$

(h) $\tan (180^\circ - \theta)$

(i) $\tan (180^\circ + \theta)$

(j) $\tan (-180^\circ + \theta)$

(k) $\tan (540^\circ - \theta)$

(l) $\tan (\theta - 360^\circ)$

Solution:

(a) $180^\circ - \theta$ is in the second quadrant where \cos is $-ve$, and the angle to the horizontal is θ , so
 $\cos (180^\circ - \theta) = -\cos \theta$

(b) $180^\circ + \theta$ is in the third quadrant, at θ to the horizontal, so
 $\cos (180^\circ + \theta) = -\cos \theta$

(c) $-\theta$ is in the fourth quadrant, at θ to the horizontal, so
 $\cos (-\theta) = +\cos \theta$

(d) $-180^\circ + \theta$ is in the third quadrant, at θ to the horizontal, so
 $\cos (-180^\circ + \theta) = -\cos \theta$

(e) $\theta - 360^\circ$ is in the first quadrant, at θ to the horizontal, so
 $\cos (\theta - 360^\circ) = +\cos \theta$

(f) $\theta - 540^\circ$ is in the third quadrant, at θ to the horizontal, so
 $\cos (\theta - 540^\circ) = -\cos \theta$

(g) $\tan (-\theta) = -\tan \theta$ as $-\theta$ is in the fourth quadrant.

(h) $\tan (180^\circ - \theta) = -\tan \theta$ as $(180^\circ - \theta)$ is in the second quadrant.

(i) $\tan (180^\circ + \theta) = +\tan \theta$ as $(180^\circ + \theta)$ is in the third quadrant.

(j) $\tan (-180^\circ + \theta) = +\tan \theta$ as $(-180^\circ + \theta)$ is in the third quadrant.

(k) $\tan (540^\circ - \theta) = -\tan \theta$ as $(540^\circ - \theta)$ is in the second quadrant.

(l) $\tan (\theta - 360^\circ) = +\tan \theta$ as $(\theta - 360^\circ)$ is in the first quadrant.

© Pearson Education Ltd 2008

Solutionbank C2

Edexcel Modular Mathematics for AS and A-Level

Graphics of trigonometric functions

Exercise C, Question 4

Question:

(Note: Do not use a calculator.)

A function f is an even function if $f(-\theta) = f(\theta)$.

A function f is an odd function if $f(-\theta) = -f(\theta)$.

Using your results from questions 2(a), 3(c) and 3(g), state whether $\sin \theta$, $\cos \theta$ and $\tan \theta$ are odd or even functions.

Solution:

As $\sin(-\theta) = -\sin \theta$ (question 2a)
 $\sin \theta$ is an odd function.

As $\cos(-\theta) = +\cos \theta$ (question 3c)
 $\cos \theta$ is an even function.

As $\tan(-\theta) = -\tan \theta$ (question 3g)
 $\tan \theta$ is an odd function.

© Pearson Education Ltd 2008

Solutionbank C2

Edexcel Modular Mathematics for AS and A-Level

Graphics of trigonometric functions

Exercise D, Question 1

Question:

Express the following as trigonometric ratios of either 30° , 45° or 60° , and hence find their exact values.

- (a) $\sin 135^\circ$
- (b) $\sin (-60^\circ)$
- (c) $\sin 330^\circ$
- (d) $\sin 420^\circ$
- (e) $\sin (-300^\circ)$
- (f) $\cos 120^\circ$
- (g) $\cos 300^\circ$
- (h) $\cos 225^\circ$
- (i) $\cos (-210^\circ)$
- (j) $\cos 495^\circ$
- (k) $\tan 135^\circ$
- (l) $\tan (-225^\circ)$
- (m) $\tan 210^\circ$
- (n) $\tan 300^\circ$
- (o) $\tan (-120^\circ)$

Solution:

(a) $\sin 135^\circ = + \sin 45^\circ$ (135° is in the second quadrant at 45° to the horizontal)

$$\text{So } \sin 135^\circ = \frac{\sqrt{2}}{2}$$

(b) $\sin (-60^\circ) = - \sin 60^\circ$ (-60° is in the fourth quadrant at 60° to the horizontal)

$$\text{So } \sin \left(-60^\circ \right) = - \frac{\sqrt{3}}{2}$$

(c) $\sin 330^\circ = - \sin 30^\circ$ (330° is in the fourth quadrant at 30° to the horizontal)

$$\text{So } \sin 330^\circ = - \frac{1}{2}$$

(d) $\sin 420^\circ = + \sin 60^\circ$ (on second revolution)

$$\text{So } \sin 420^\circ = \frac{\sqrt{3}}{2}$$

$$\text{(e) } \sin (-300)^\circ = +\sin 60^\circ \text{ (} -300^\circ \text{ is in the first quadrant at } 60^\circ \text{ to the horizontal)}$$

$$\text{So } \sin \left(-300 \right)^\circ = \frac{\sqrt{3}}{2}$$

$$\text{(f) } \cos 120^\circ = -\cos 60^\circ \text{ (} 120^\circ \text{ is in the second quadrant at } 60^\circ \text{ to the horizontal)}$$

$$\text{So } \cos 120^\circ = -\frac{1}{2}$$

$$\text{(g) } \cos 300^\circ = +\cos 60^\circ \text{ (} 300^\circ \text{ is in the fourth quadrant at } 60^\circ \text{ to the horizontal)}$$

$$\text{So } \cos 300^\circ = \frac{1}{2}$$

$$\text{(h) } \cos 225^\circ = -\cos 45^\circ \text{ (} 225^\circ \text{ is in the third quadrant at } 45^\circ \text{ to the horizontal)}$$

$$\text{So } \cos 225^\circ = -\frac{\sqrt{2}}{2}$$

$$\text{(i) } \cos (-210^\circ) = -\cos 30^\circ \text{ (} -210^\circ \text{ is in the second quadrant at } 30^\circ \text{ to the horizontal)}$$

$$\text{So } \cos \left(-210^\circ \right) = -\frac{\sqrt{3}}{2}$$

$$\text{(j) } \cos 495^\circ = -\cos 45^\circ \text{ (} 495^\circ \text{ is in the second quadrant at } 45^\circ \text{ to the horizontal)}$$

$$\text{So } \cos 495^\circ = -\frac{\sqrt{2}}{2}$$

$$\text{(k) } \tan 135^\circ = -\tan 45^\circ \text{ (} 135^\circ \text{ is in the second quadrant at } 45^\circ \text{ to the horizontal)}$$

$$\text{So } \tan 135^\circ = -1$$

$$\text{(l) } \tan (-225^\circ) = -\tan 45^\circ \text{ (} -225^\circ \text{ is in the second quadrant at } 45^\circ \text{ to the horizontal)}$$

$$\text{So } \tan (-225^\circ) = -1$$

$$\text{(m) } \tan 210^\circ = +\tan 30^\circ \text{ (} 210^\circ \text{ is in the third quadrant at } 30^\circ \text{ to the horizontal)}$$

$$\text{So } \tan 210^\circ = \frac{\sqrt{3}}{3}$$

$$\text{(n) } \tan 300^\circ = -\tan 60^\circ \text{ (} 300^\circ \text{ is in the fourth quadrant at } 60^\circ \text{ to the horizontal)}$$

$$\text{So } \tan 300^\circ = -\sqrt{3}$$

$$\text{(o) } \tan (-120^\circ) = +\tan 60^\circ \text{ (} -120^\circ \text{ is in the third quadrant at } 60^\circ \text{ to the horizontal)}$$

$$\text{So } \tan (-120^\circ) = \sqrt{3}$$

Solutionbank C2

Edexcel Modular Mathematics for AS and A-Level

Graphics of trigonometric functions

Exercise D, Question 2

Question:

In Section 8.3 you saw that $\sin 30^\circ = \cos 60^\circ$, $\cos 30^\circ = \sin 60^\circ$, and $\tan 60^\circ = \frac{1}{\tan 30^\circ}$. These are particular examples of the general results: $\sin (90^\circ - \theta) = \cos \theta$, and $\cos (90^\circ - \theta) = \sin \theta$, and $\tan (90^\circ - \theta) = \frac{1}{\tan \theta}$, where the angle θ is measured in degrees. Use a right-angled triangle ABC to verify these results for the case when θ is acute.

Solution:

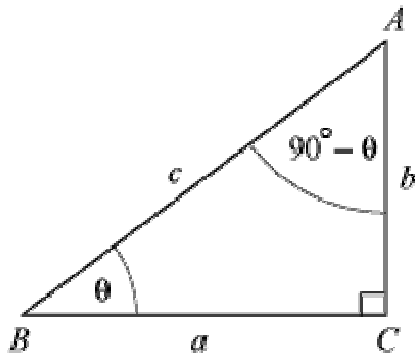

With $\angle B = \theta$, $\angle A = (90^\circ - \theta)$

$$\sin \theta = \frac{b}{c}, \cos (90^\circ - \theta) = \frac{b}{c}$$

So $\cos (90^\circ - \theta) = \sin \theta$

$$\cos \theta = \frac{a}{c}, \sin (90^\circ - \theta) = \frac{a}{c}$$

So $\sin (90^\circ - \theta) = \cos \theta$

$$\tan \theta = \frac{b}{a}, \tan (90^\circ - \theta) = \frac{a}{b} = \frac{1}{\left(\frac{b}{a}\right)} = \frac{1}{\tan \theta}$$

Solutionbank C2

Edexcel Modular Mathematics for AS and A-Level

Graphics of trigonometric functions

Exercise E, Question 1

Question:

Sketch the graph of $y = \cos \theta$ in the interval $-\pi \leq \theta \leq \pi$.

Solution:

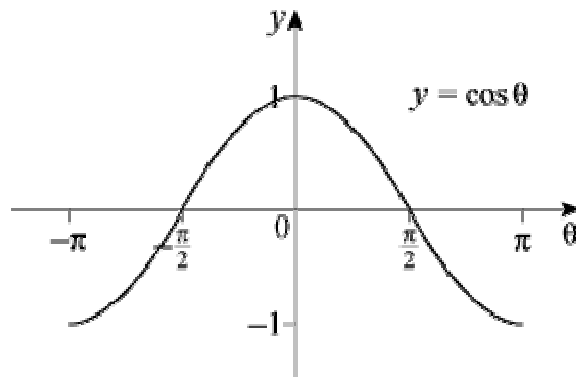

Solutionbank C2

Edexcel Modular Mathematics for AS and A-Level

Graphics of trigonometric functions

Exercise E, Question 2

Question:

Sketch the graph of $y = \tan \theta^\circ$ in the interval $-180 \leq \theta \leq 180$.

Solution:

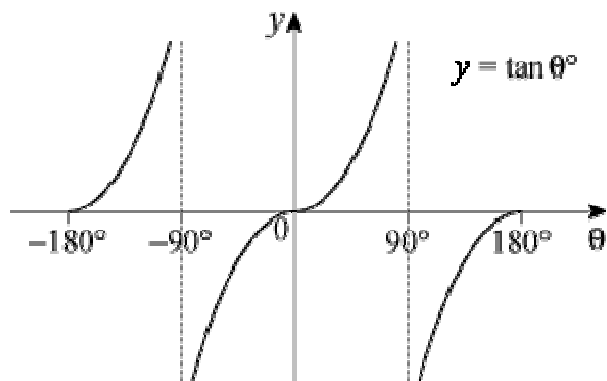

© Pearson Education Ltd 2008

Solutionbank C2

Edexcel Modular Mathematics for AS and A-Level

Graphics of trigonometric functions

Exercise E, Question 3

Question:

Sketch the graph of $y = \sin \theta^\circ$ in the interval $-90 \leq \theta \leq 270$.

Solution:

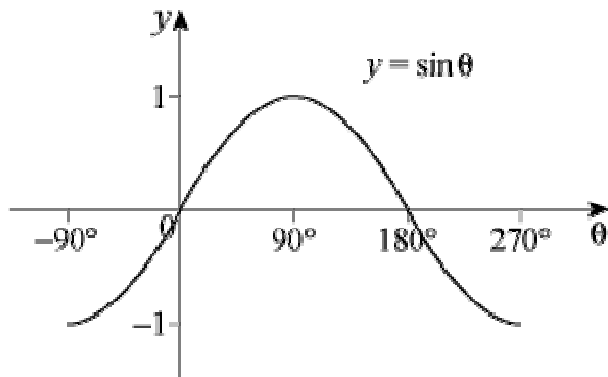

Solutionbank C2

Edexcel Modular Mathematics for AS and A-Level

Graphics of trigonometric functions

Exercise F, Question 1

Question:

Write down (i) the maximum value, and (ii) the minimum value, of the following expressions, and in each case give the smallest positive (or zero) value of x for which it occurs.

(a) $\cos x^\circ$

(b) $4 \sin x^\circ$

(c) $\cos(-x)^\circ$

(d) $3 + \sin x^\circ$

(e) $-\sin x^\circ$

(f) $\sin 3x^\circ$

Solution:

(a) (i) Maximum value of $\cos x^\circ = 1$, occurs when $x = 0$.

(ii) Minimum value is -1 , occurs when $x = 180$.

(b) (i) Maximum value of $\sin x^\circ = 1$, so maximum value of $4 \sin x^\circ = 4$, occurs when $x = 90$.

(ii) Minimum value of $4 \sin x^\circ$ is -4 , occurs when $x = 270$.

(c) The graph of $\cos(-x)^\circ$ is a reflection of the graph of $\cos x^\circ$ in the y -axis.

This is the same curve; $\cos(-x)^\circ = \cos x^\circ$.

(i) Maximum value of $\cos(-x)^\circ = 1$, occurs when $x = 0$.

(ii) Minimum value of $\cos(-x)^\circ = -1$, occurs when $x = 180$.

(d) The graph of $3 + \sin x^\circ$ is the graph of $\sin x^\circ$ translated by $+3$ vertically.

(i) Maximum = 4 , when $x = 90$.

(ii) Minimum = 2 , when $x = 270$.

(e) The graph of $-\sin x^\circ$ is the reflection of the graph of $\sin x^\circ$ in the x -axis.

(i) Maximum = 1 , when $x = 270$.

(ii) Minimum = -1 , when $x = 90$.

(f) The graph of $\sin 3x^\circ$ is the graph of $\sin x^\circ$ stretched by $\frac{1}{3}$ in the x direction.

(i) Maximum = 1 , when $x = 30$.

(ii) Minimum = -1 , when $x = 90$.

Solutionbank C2

Edexcel Modular Mathematics for AS and A-Level

Graphics of trigonometric functions

Exercise F, Question 2

Question:

Sketch, on the same set of axes, in the interval $0 \leq \theta \leq 360^\circ$, the graphs of $\cos \theta$ and $\cos 3\theta$.

Solution:

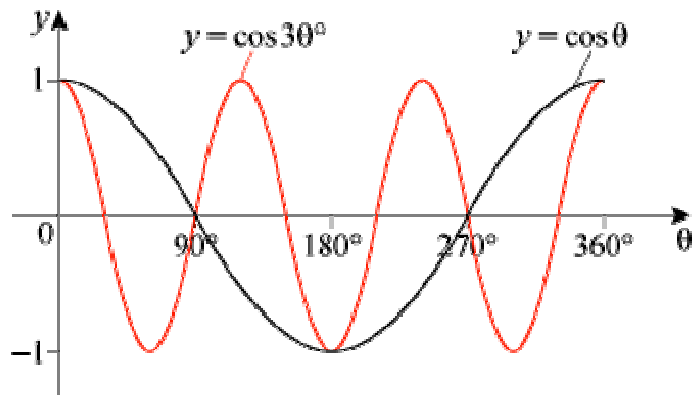

Solutionbank C2

Edexcel Modular Mathematics for AS and A-Level

Graphics of trigonometric functions

Exercise F, Question 3

Question:

Sketch, on separate axes, the graphs of the following, in the interval $0 \leq \theta \leq 360^\circ$. Give the coordinates of points of intersection with the axes, and of maximum and minimum points where appropriate.

(a) $y = -\cos \theta$

(b) $y = \frac{1}{3} \sin \theta$

(c) $y = \sin \frac{1}{3}\theta$

(d) $y = \tan (\theta - 45^\circ)$

Solution:

(a) The graph of $y = -\cos \theta$ is the graph of $y = \cos \theta$ reflected in the θ -axis.

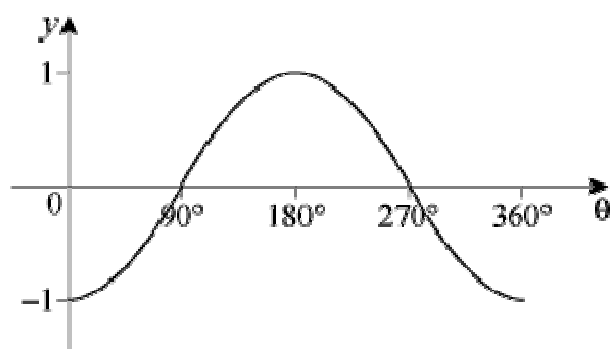

Meets θ -axis at $(90^\circ, 0)$, $(270^\circ, 0)$

Meets y -axis at $(0^\circ, -1)$

Maximum at $(180^\circ, 1)$

Minima at $(0^\circ, -1)$ and $(360^\circ, -1)$

(b) The graph of $y = \frac{1}{3} \sin \theta$ is the graph of $y = \sin \theta$ stretched by scale factor $\frac{1}{3}$ in y direction.

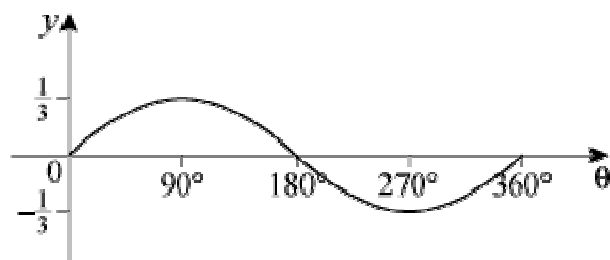

Meets θ -axis at $(0^\circ, 0)$, $(180^\circ, 0)$, $(360^\circ, 0)$

Meets y -axis at $(0^\circ, 0)$

Maximum at $\left(90^\circ, \frac{1}{3} \right)$

Minimum at $\left(270^\circ, -\frac{1}{3} \right)$

(c) The graph of $y = \sin \frac{1}{3}\theta$ is the graph of $y = \sin \theta$ stretched by scale factor 3 in θ direction.

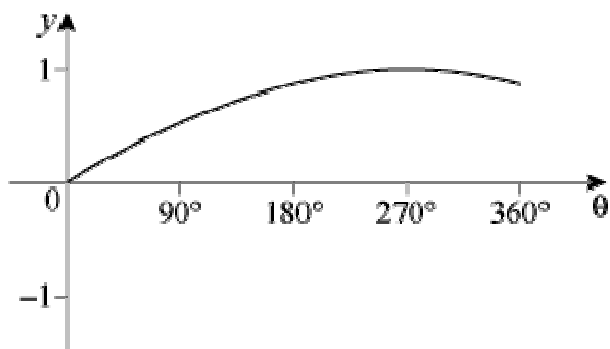

Only meets axes at origin

Maximum at $(270^\circ, 1)$

(d) The graph of $y = \tan (\theta - 45^\circ)$ is the graph of $\tan \theta$ translated by 45° to the right.

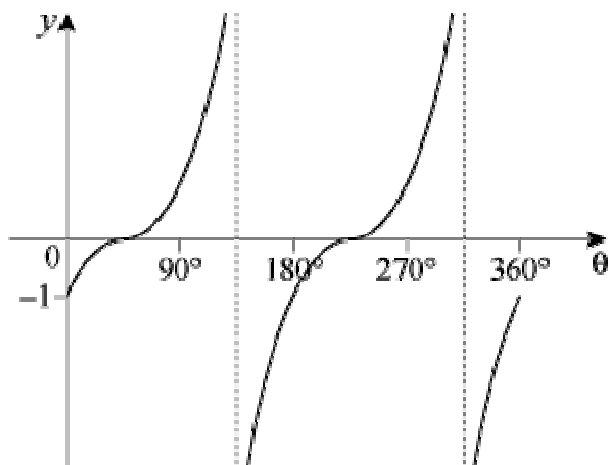

Meets θ -axis at $(45^\circ, 0)$, $(225^\circ, 0)$

Meets y -axis at $(0^\circ, -1)$

(Asymptotes at $\theta = 135^\circ$ and $\theta = 315^\circ$)

Solutionbank C2

Edexcel Modular Mathematics for AS and A-Level

Graphics of trigonometric functions

Exercise F, Question 4

Question:

Sketch, on separate axes, the graphs of the following, in the interval $-180 \leq \theta \leq 180$. Give the coordinates of points of intersection with the axes, and of maximum and minimum points where appropriate.

(a) $y = -2 \sin \theta^\circ$

(b) $y = \tan (\theta + 180)^\circ$

(c) $y = \cos 4\theta^\circ$

(d) $y = \sin (-\theta)^\circ$

Solution:

(a) This is the graph of $y = \sin \theta^\circ$ stretched by scale factor -2 in the y direction (i.e. reflected in the θ -axis and scaled by 2 in the y direction).

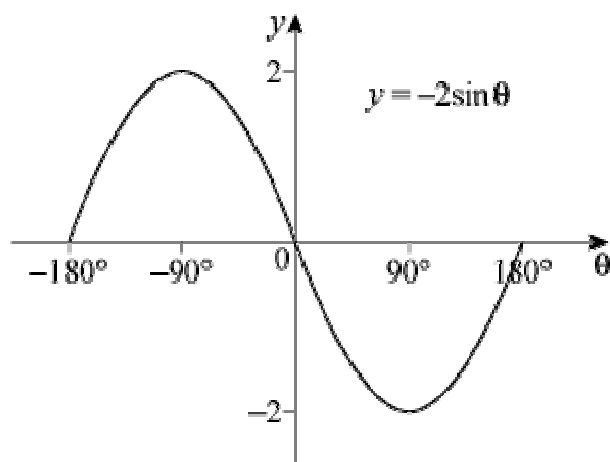

Meets θ -axis at $(-180^\circ, 0)$, $(0^\circ, 0)$, $(180^\circ, 0)$

Maximum at $(-90^\circ, 2)$

Minimum at $(90^\circ, -2)$

(b) This is the graph of $y = \tan \theta^\circ$ translated by 180° to the left.

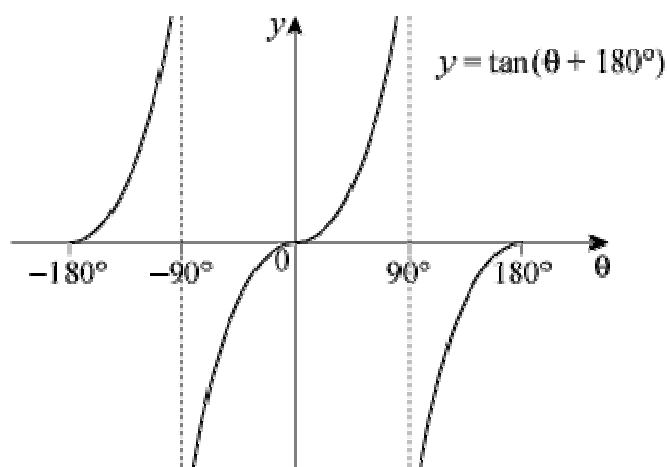

As $\tan \theta^\circ$ has a period of 180°

$$\tan(\theta + 180)^\circ = \tan \theta^\circ$$

Meets θ -axis at $(-180^\circ, 0)$, $(0^\circ, 0)$, $(180^\circ, 0)$

(c) This is the graph of $y = \cos \theta^\circ$ stretched by scale factor $\frac{1}{4}$ horizontally.

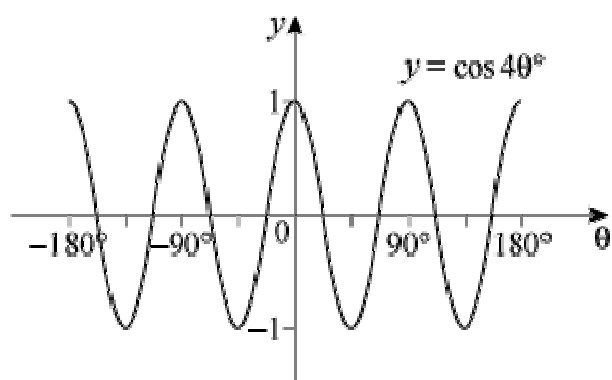

Meets θ -axis at $\left(-157\frac{1}{2}^\circ, 0\right)$, $\left(-112\frac{1}{2}^\circ, 0\right)$, $\left(-67\frac{1}{2}^\circ, 0\right)$, $\left(-22\frac{1}{2}^\circ, 0\right)$, $\left(22\frac{1}{2}^\circ, 0\right)$, $\left(67\frac{1}{2}^\circ, 0\right)$, $\left(112\frac{1}{2}^\circ, 0\right)$, $\left(157\frac{1}{2}^\circ, 0\right)$

Meets y -axis at $(0^\circ, 1)$

Maxima at $(-180^\circ, 1)$, $(-90^\circ, 1)$, $(0^\circ, 1)$, $(90^\circ, 1)$, $(180^\circ, 1)$

Minima at $(-135^\circ, -1)$, $(-45^\circ, -1)$, $(45^\circ, -1)$, $(135^\circ, -1)$

(d) This is the graph of $y = \sin \theta^\circ$ reflected in the y -axis. (This is the same as $y = -\sin \theta^\circ$.)

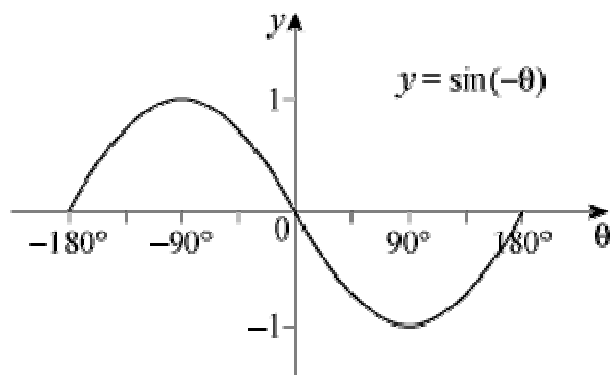

Meets θ -axis at $(-180^\circ, 0)$, $(0^\circ, 0)$, $(180^\circ, 0)$

Maximum at $(-90^\circ, 1)$

Minimum at $(90^\circ, -1)$

© Pearson Education Ltd 2008

Solutionbank C2

Edexcel Modular Mathematics for AS and A-Level

Graphics of trigonometric functions

Exercise F, Question 5

Question:

In this question θ is measured in radians. Sketch, on separate axes, the graphs of the following in the interval $-2\pi \leq \theta \leq 2\pi$. In each case give the periodicity of the function.

(a) $y = \sin \frac{1}{2}\theta$

(b) $y = -\frac{1}{2}\cos \theta$

(c) $y = \tan \left(\theta - \frac{\pi}{2} \right)$

(d) $y = \tan 2\theta$

Solution:

(a) This is the graph of $y = \sin \theta$ stretched by scale factor 2 horizontally.
Period = 4π

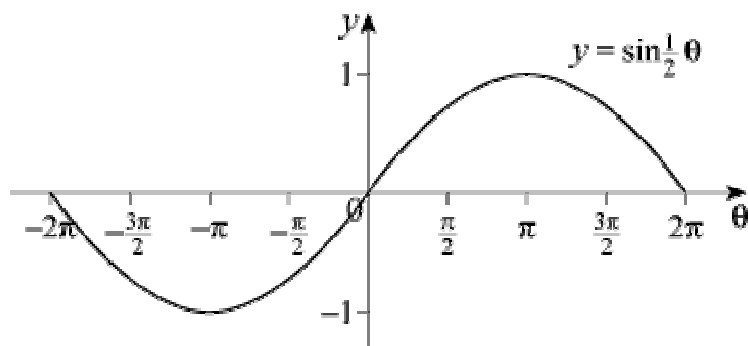

(b) This is the graph of $y = \cos \theta$ stretched by scale factor $-\frac{1}{2}$ vertically.

(Equivalent to reflection, in θ -axis and stretching vertically by $+\frac{1}{2}$.)

Period = 2π

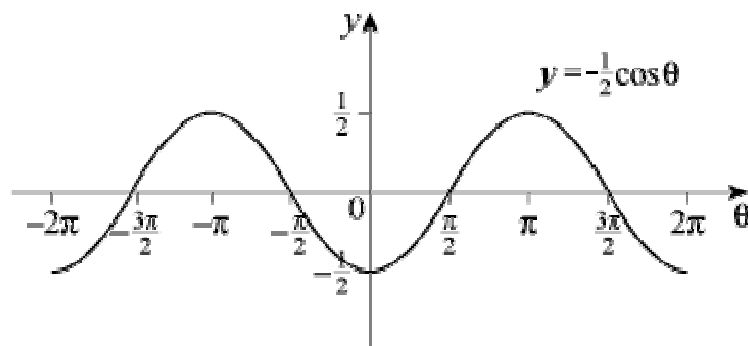

(c) This is the graph of $y = \tan \theta$ translated by $\frac{\pi}{2}$ to the right.

Period = π

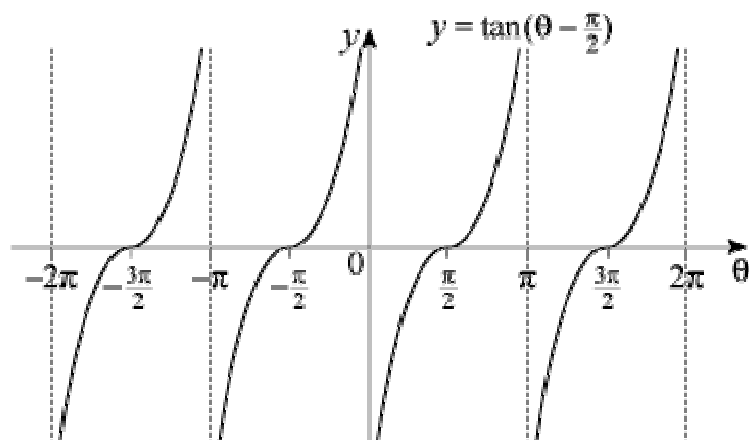

(d) This is the graph of $y = \tan \theta$ stretched by scale factor $\frac{1}{2}$ horizontally.

Period = $\frac{\pi}{2}$

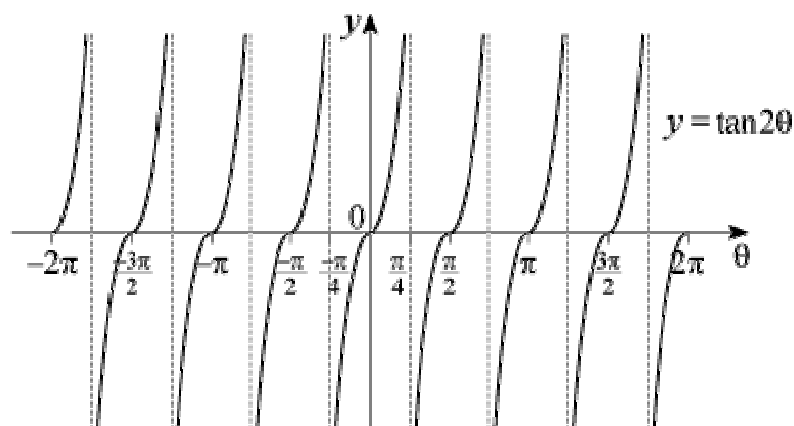

© Pearson Education Ltd 2008

Solutionbank C2

Edexcel Modular Mathematics for AS and A-Level

Graphics of trigonometric functions

Exercise F, Question 6

Question:

(a) By considering the graphs of the functions, or otherwise, verify that:

(i) $\cos \theta = \cos (-\theta)$

(ii) $\sin \theta = -\sin (-\theta)$

(iii) $\sin (\theta - 90^\circ) = -\cos \theta$

(b) Use the results in (a) (ii) and (iii) to show that $\sin (90^\circ - \theta) = \cos \theta$.

(c) In Example 11 you saw that $\cos (\theta - 90^\circ) = \sin \theta$. Use this result with part (a) (i) to show that $\cos (90^\circ - \theta) = \sin \theta$.

Solution:

(a) (i) $y = \cos (-\theta)$ is a reflection of $y = \cos \theta$ in the y -axis, which is the same curve, so $\cos \theta = \cos (-\theta)$.

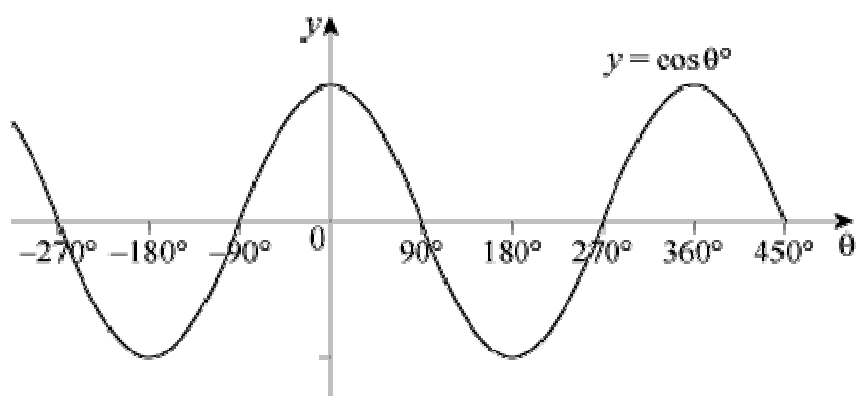

(ii) $y = \sin (-\theta)$ is a reflection of $y = \sin \theta$ in the y -axis

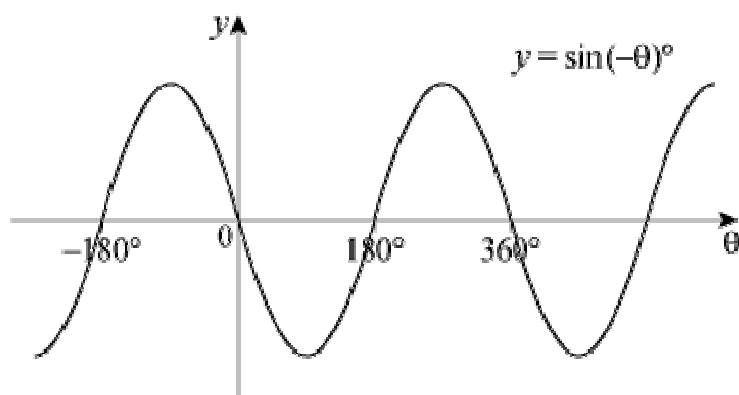

$y = -\sin (-\theta)$ is a reflection of $y = \sin (-\theta)$ in the θ -axis, which is the graph of $y = \sin \theta$, so $-\sin (-\theta) = \sin \theta$.

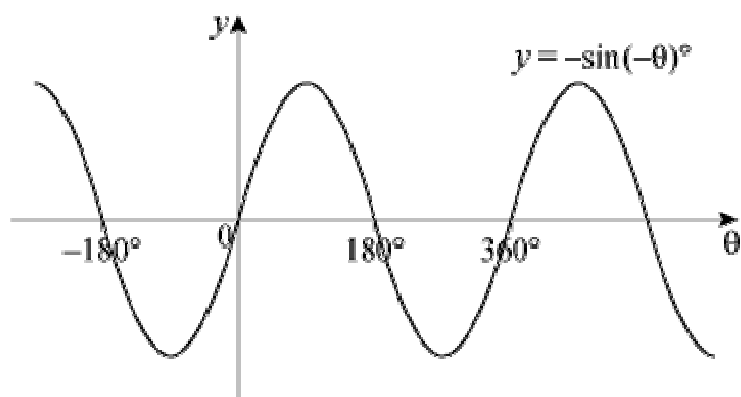

(iii) $y = \sin(\theta - 90^\circ)$ is the graph of $y = \sin \theta$ translated by 90° to the right, which is the graph of $y = -\cos \theta$, so $\sin(\theta - 90^\circ) = -\cos \theta$.

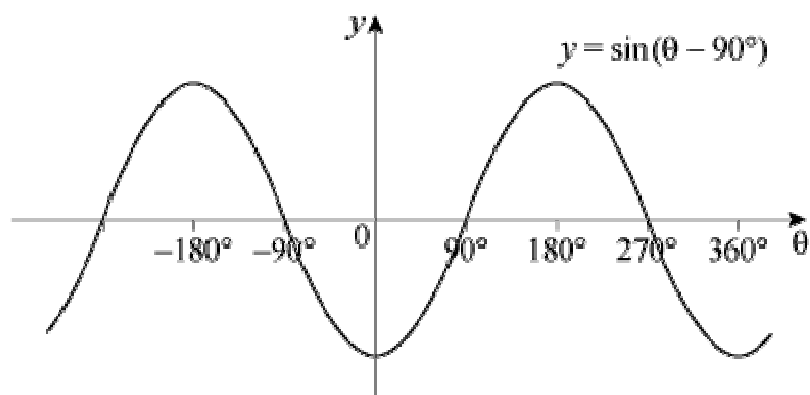

(b) Using (a) (ii), $\sin(90^\circ - \theta) = -\sin[-(90^\circ - \theta)] = -\sin(\theta - 90^\circ)$
 Using (a) (iii), $-\sin(\theta - 90^\circ) = -(-\cos \theta) = \cos \theta$
 So $\sin(90^\circ - \theta) = \cos \theta$.

(c) Using (a)(i), $\cos(90^\circ - \theta) = \cos(\theta - 90^\circ) = \sin \theta$, using Example 11.

Solutionbank C2

Edexcel Modular Mathematics for AS and A-Level

Graphics of trigonometric functions

Exercise G, Question 1

Question:

Write each of the following as a trigonometric ratio of an acute angle:

(a) $\cos 237^\circ$

(b) $\sin 312^\circ$

(c) $\tan 190^\circ$

(d) $\sin 2.3^\circ$

(e) $\cos \left(-\frac{\pi}{15} \right)$

Solution:

(a) 237° is in the third quadrant so $\cos 237^\circ$ is $-ve$.

The angle made with the horizontal is 57° .

So $\cos 237^\circ = -\cos 57^\circ$

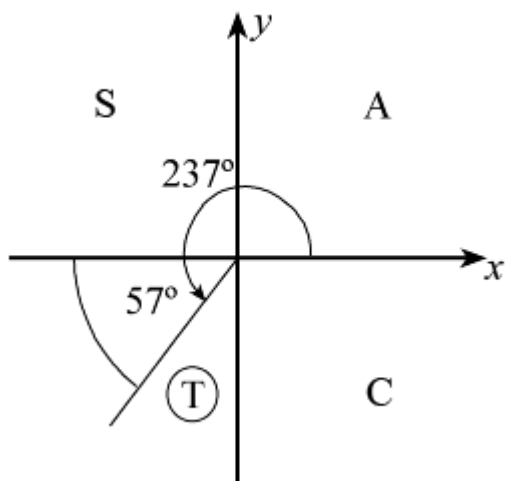

(b) 312° is in the fourth quadrant so $\sin 312^\circ$ is $-ve$.

The angle to the horizontal is 48° .

So $\sin 312^\circ = -\sin 48^\circ$

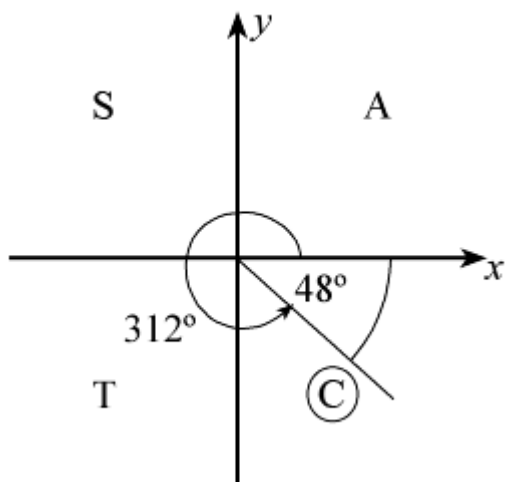

(c) 190° is in the third quadrant so $\tan 190^\circ$ is +ve.
 The angle to the horizontal is 10° .
 So $\tan 190^\circ = +\tan 10^\circ$

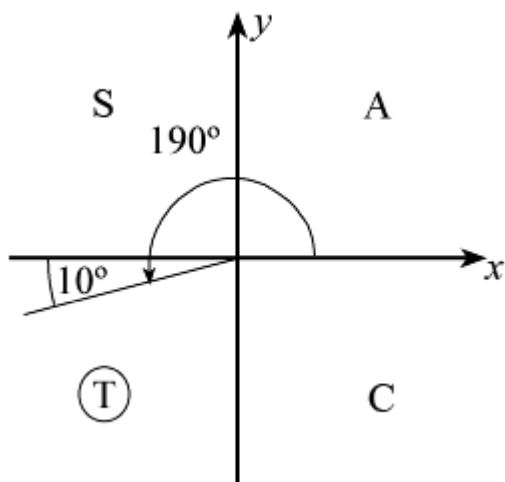

(d) 2.3 radians ($131.78 \dots^\circ$) is in the second quadrant so $\sin 2.3^c$ is +ve.
 The angle to the horizontal is $(\pi - 2.3)$ radians = 0.84 radians (2 s.f.).
 So $\sin 2.3^c = +\sin 0.84^c$

(e) $-\left(\frac{\pi}{15}\right)$ is in the fourth quadrant so $\cos\left(-\frac{\pi}{15}\right)$ is +ve.

The angle to the horizontal is $\frac{\pi}{15}$.

So $\cos\left(-\frac{\pi}{15}\right) = +\cos\left(\frac{\pi}{15}\right)$

Solutionbank C2

Edexcel Modular Mathematics for AS and A-Level

Graphics of trigonometric functions

Exercise G, Question 2

Question:

Without using your calculator, work out the values of:

(a) $\cos 270^\circ$

(b) $\sin 225^\circ$

(c) $\cos 180^\circ$

(d) $\tan 240^\circ$

(e) $\tan 135^\circ$

(f) $\cos 690^\circ$

(g) $\sin \frac{5\pi}{3}$

(h) $\cos \left(-\frac{2\pi}{3} \right)$

(i) $\tan 2\pi$

(j) $\sin \left(-\frac{7\pi}{6} \right)$

Solution:

(a) $\sin 270^\circ = -1$ (see graph of $y = \sin \theta$)

(b) $\sin 225^\circ = \sin \left(180 + 45 \right)^\circ = -\sin 45^\circ = -\frac{\sqrt{2}}{2}$

(c) $\cos 180^\circ = -1$ (see graph of $y = \cos \theta$)

(d) $\tan 240^\circ = \tan (180 + 60)^\circ = +\tan 60^\circ$ (third quadrant)
So $\tan 240^\circ = +\sqrt{3}$

(e) $\tan 135^\circ = -\tan 45^\circ$ (second quadrant)
So $\tan 135^\circ = -1$

(f) $\cos 690^\circ = \cos (360 + 330)^\circ = \cos 330^\circ = +\cos 30^\circ$ (fourth quadrant)
So $\cos 690^\circ = +\frac{\sqrt{3}}{2}$

$$(g) \sin \frac{5\pi}{3} = -\sin \frac{\pi}{3} \text{ (fourth quadrant)}$$

$$\text{So } \sin \frac{5\pi}{3} = -\frac{\sqrt{3}}{2}$$

$$(h) \cos \left(-\frac{2\pi}{3} \right) = -\cos \frac{\pi}{3} \text{ (third quadrant)}$$

$$\text{So } \cos \left(-\frac{2\pi}{3} \right) = -\frac{1}{2}$$

$$(i) \tan 2\pi = 0 \text{ (see graph of } y = \tan \theta \text{)}$$

$$(j) \sin \left(-\frac{7\pi}{6} \right) = +\sin \left(\frac{\pi}{6} \right) \text{ (second quadrant)}$$

$$\text{So } \sin \left(-\frac{7\pi}{6} \right) = +\frac{1}{2}$$

Solutionbank C2

Edexcel Modular Mathematics for AS and A-Level

Graphics of trigonometric functions

Exercise G, Question 3

Question:

Describe geometrically the transformations which map:

- (a) The graph of $y = \tan x^\circ$ onto the graph of $\tan \frac{1}{2}x^\circ$.
- (b) The graph of $y = \tan \frac{1}{2}x^\circ$ onto the graph of $3 + \tan \frac{1}{2}x^\circ$.
- (c) The graph of $y = \cos x^\circ$ onto the graph of $-\cos x^\circ$.
- (d) The graph of $y = \sin (x - 10)^\circ$ onto the graph of $\sin (x + 10)^\circ$.

Solution:

- (a) A stretch of scale factor 2 in the x direction.
- (b) A translation of $+3$ in the y direction.
- (c) A reflection in the x -axis
- (d) A translation of $+20$ in the negative x direction (i.e. 20 to the left).

© Pearson Education Ltd 2008

Solutionbank C2

Edexcel Modular Mathematics for AS and A-Level

Graphics of trigonometric functions

Exercise G, Question 4

Question:

(a) Sketch on the same set of axes, in the interval $0 \leq x \leq \pi$, the graphs of $y = \tan\left(x - \frac{1}{4}\pi\right)$ and $y = -2 \cos x$, showing the coordinates of points of intersection with the axes.

(b) Deduce the number of solutions of the equation $\tan\left(x - \frac{1}{4}\pi\right) + 2 \cos x = 0$, in the interval $0 \leq x \leq \pi$.

Solution:

4 (a)

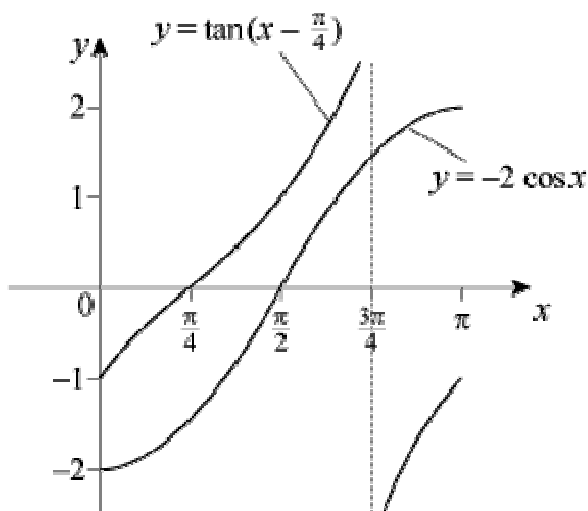

(b) There are no solutions of $\tan\left(x - \frac{\pi}{4}\right) + 2 \cos x = 0$ in the interval $0 \leq x \leq \pi$, since $y = \tan\left(x - \frac{\pi}{4}\right)$ and $y = -2 \cos x$ do not intersect in the interval.

Solutionbank C2

Edexcel Modular Mathematics for AS and A-Level

Graphics of trigonometric functions

Exercise G, Question 5

Question:

The diagram shows part of the graph of $y = f(x)$. It crosses the x -axis at $A(120, 0)$ and $B(p, 0)$. It crosses the y -axis at $C(0, q)$ and has a maximum value at D , as shown.

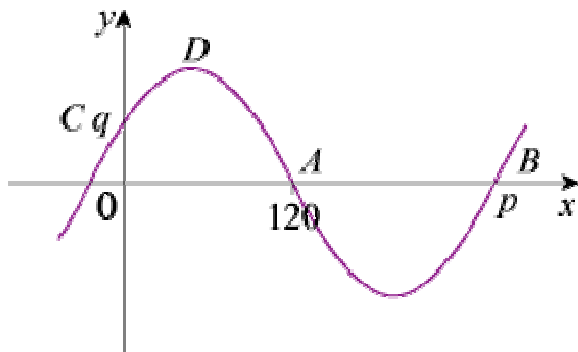

Given that $f(x) = \sin(x + k)^\circ$, where $k > 0$, write down:

- the value of p
- the coordinates of D
- the smallest value of k
- the value of q

Solution:

(a) As it is the graph of $y = \sin x^\circ$ translated, the gap between A and B is 180, so $p = 300$.

(b) The difference in the x -coordinates of D and A is 90, so the x -coordinate of D is 30.
The maximum value of y is 1, so $D = (30, 1)$.

(c) For the graph of $y = \sin x^\circ$, the first positive intersection with the x -axis would occur at 180. The point A is at 120 and so the curve has been translated by 60 to the left.
 $k = 60$

(d) The equation of the curve is $y = \sin(x + 60)^\circ$.

When $x = 0$, $y = \sin 60^\circ = \frac{\sqrt{3}}{2}$, so $q = \frac{\sqrt{3}}{2}$.

Solutionbank C2

Edexcel Modular Mathematics for AS and A-Level

Graphics of trigonometric functions

Exercise G, Question 6

Question:

Consider the function $f(x) = \sin px$, $p \in \mathbb{R}$, $0 \leq x \leq 2\pi$.

The closest point to the origin that the graph of $f(x)$ crosses the x -axis has x -coordinate $\frac{\pi}{5}$.

- (a) Sketch the graph of $f(x)$.
- (b) Write down the period of $f(x)$.
- (c) Find the value of p .

Solution:

(a) The graph is that of $y = \sin x$ stretched in the x direction.

Each 'half-wave' has interval $\frac{\pi}{5}$.

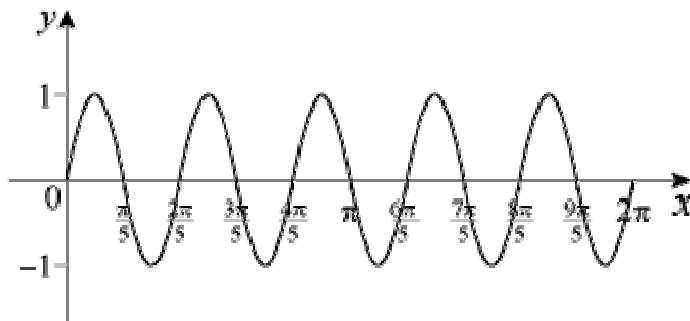

(b) The period is a 'wavelength', i.e. $\frac{2\pi}{5}$.

(c) The stretch factor is $\frac{1}{p}$.

As 2π has been reduced to $\frac{2\pi}{5}$, 2π has been multiplied by $\frac{1}{5}$ which is $\frac{1}{p} \Rightarrow p = 5$.

The curve is $y = \sin 5x$, there are 5 'waves' in 0 to 2π .

Solutionbank C2

Edexcel Modular Mathematics for AS and A-Level

Graphics of trigonometric functions

Exercise G, Question 7

Question:

The graph below shows $y = \sin \theta$, $0 \leq \theta \leq 360^\circ$, with one value of θ ($\theta = \alpha^\circ$) marked on the axis.

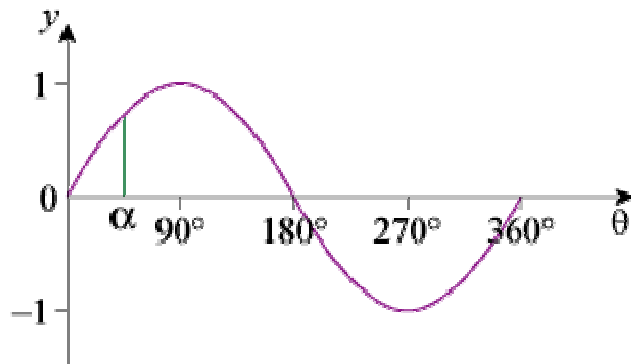

(a) Copy the graph and mark on the θ -axis the positions of $(180 - \alpha)^\circ$, $(180 + \alpha)^\circ$, and $(360 - \alpha)^\circ$.

(b) Establish the result $\sin \alpha^\circ = \sin (180 - \alpha)^\circ = -\sin (180 + \alpha)^\circ = -\sin (360 - \alpha)^\circ$.

Solution:

(a) The four shaded regions are congruent.

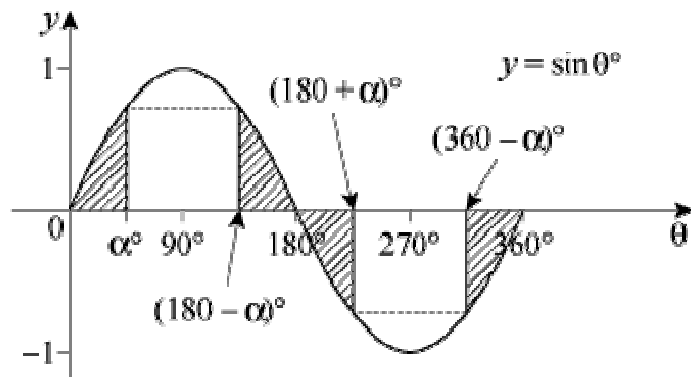

(b) $\sin \alpha^\circ$ and $\sin (180 - \alpha)^\circ$ have the same y value (call it k).

So $\sin \alpha^\circ = \sin (180 - \alpha)^\circ$

$\sin (180 + \alpha)^\circ$ and $\sin (360 - \alpha)^\circ$ have the same y value, which will be $-k$.

So $\sin \alpha^\circ = \sin (180 - \alpha)^\circ = -\sin (180 + \alpha)^\circ = -\sin (360 - \alpha)^\circ$

Solutionbank C2

Edexcel Modular Mathematics for AS and A-Level

Graphics of trigonometric functions

Exercise G, Question 8

Question:

(a) Sketch on separate axes the graphs of $y = \cos \theta$ ($0 \leq \theta \leq 360^\circ$) and $y = \tan \theta$ ($0 \leq \theta \leq 360^\circ$), and on each θ -axis mark the point $(\alpha^\circ, 0)$ as in question 7.

(b) Verify that:

(i) $\cos \alpha^\circ = -\cos (180 - \alpha)^\circ = -\cos (180 + \alpha)^\circ = \cos (360 - \alpha)^\circ$.

(ii) $\tan \alpha^\circ = -\tan (180 - \alpha)^\circ = -\tan (180 + \alpha)^\circ = -\tan (360 - \alpha)^\circ$.

Solution:

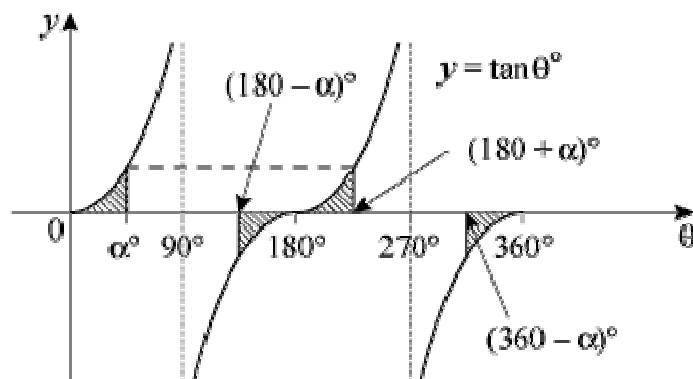
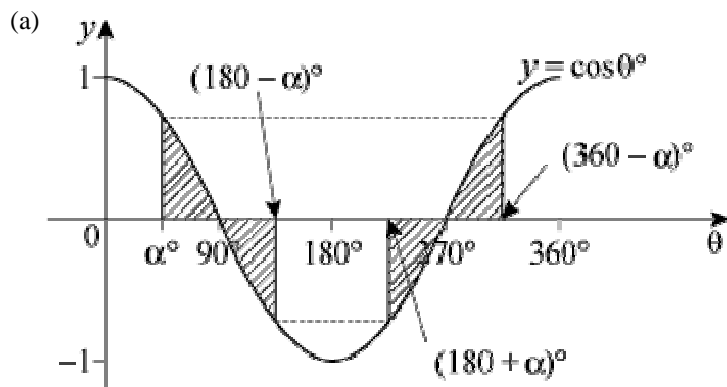

(b) (i) From the graph of $y = \cos \theta^\circ$, which shows four congruent shaded regions, if the y value at α° is k , then y at $(180 - \alpha)^\circ$ is $-k$, y at $(180 + \alpha)^\circ$ is $-k$ and y at $(360 - \alpha)^\circ$ is $+k$.
So $\cos \alpha^\circ = -\cos (180 - \alpha)^\circ = -\cos (180 + \alpha)^\circ = \cos (360 - \alpha)^\circ$

(ii) From the graph of $y = \tan \theta^\circ$, if the y value at α° is k , then at $(180 - \alpha)^\circ$ it is $-k$, at $(180 + \alpha)^\circ$ it is $+k$ and at $(360 - \alpha)^\circ$ it is $-k$.
So $\tan \alpha^\circ = -\tan (180 - \alpha)^\circ = +\tan (180 + \alpha)^\circ = -\tan (360 - \alpha)^\circ$

Solutionbank C2

Edexcel Modular Mathematics for AS and A-Level

Differentiation

Exercise A, Question 1

Question:

Find the values of x for which $f(x)$ is an increasing function, given that $f(x)$ equals:

(a) $3x^2 + 8x + 2$

(b) $4x - 3x^2$

(c) $5 - 8x - 2x^2$

(d) $2x^3 - 15x^2 + 36x$

(e) $3 + 3x - 3x^2 + x^3$

(f) $5x^3 + 12x$

(g) $x^4 + 2x^2$

(h) $x^4 - 8x^3$

Solution:

(a) $f(x) = 3x^2 + 8x + 2$

$f'(x) = 6x + 8$

$f'(x) > 0 \Rightarrow 6x + 8 > 0$

So $x > \frac{-8}{6}$

i.e. $x > \frac{-4}{3}$

(b) $f(x) = 4x - 3x^2$

$f'(x) = 4 - 6x$

$f'(x) > 0 \Rightarrow 4 - 6x > 0$

So $4 > 6x$

i.e. $6x < 4$

$x < \frac{4}{6}$

$x < \frac{2}{3}$

(c) $f(x) = 5 - 8x - 2x^2$

$f'(x) = -8 - 4x$

$f'(x) > 0 \Rightarrow -8 - 4x > 0$

So $-8 > 4x$ (add $4x$ to both sides)

i.e. $4x < -8$

$x < -2$

(d) $f(x) = 2x^3 - 15x^2 + 36x$

$f'(x) = 6x^2 - 30x + 36$

$$f'(x) > 0 \Rightarrow 6x^2 - 30x + 36 > 0$$

$$\text{So } 6(x^2 - 5x + 6) > 0$$

$$\text{i.e. } 6(x - 2)(x - 3) > 0$$

By considering the 3 regions

	$x < 2$	$2 < x < 3$	$x > 3$
$6(x - 2)(x - 3)$	+ve	-ve	+ve

Then $x < 2$ or $x > 3$

$$(e) f(x) = 3 + 3x - 3x^2 + x^3$$

$$f'(x) = 3 - 6x + 3x^2$$

$$f'(x) > 0 \Rightarrow 3 - 6x + 3x^2 > 0$$

$$\text{So } 3(x^2 - 2x + 1) > 0$$

$$\text{i.e. } 3(x - 1)^2 > 0$$

$$\text{So } x \in \mathbb{R}, x \neq 1$$

$$(f) f(x) = 5x^3 + 12x$$

$$f'(x) = 15x^2 + 12$$

$$f'(x) > 0 \Rightarrow 15x^2 + 12 > 0$$

This is true for all real values of x .

$$\text{So } x \in \mathbb{R}$$

$$(g) f(x) = x^4 + 2x^2$$

$$f'(x) = 4x^3 + 4x$$

$$f'(x) > 0 \Rightarrow 4x^3 + 4x > 0$$

$$\text{So } 4x(x^2 + 1) > 0$$

$$\text{As } x^2 + 1 > 0 \text{ for all } x, x > 0$$

$$(h) f(x) = x^4 - 8x^3$$

$$f'(x) = 4x^3 - 24x^2$$

$$f'(x) > 0 \Rightarrow 4x^3 - 24x^2 > 0$$

$$\text{So } 4x^2(x - 6) > 0$$

$$\text{As } x^2 > 0 \text{ for all } x, x - 6 > 0$$

$$\text{So } x > 6$$

Solutionbank C2

Edexcel Modular Mathematics for AS and A-Level

Differentiation

Exercise A, Question 2

Question:

Find the values of x for which $f(x)$ is a decreasing function, given that $f(x)$ equals:

(a) $x^2 - 9x$

(b) $5x - x^2$

(c) $4 - 2x - x^2$

(d) $2x^3 - 3x^2 - 12x$

(e) $1 - 27x + x^3$

(f) $x + \frac{25}{x}$

(g) $x^{\frac{1}{2}} + 9x^{-\frac{1}{2}}$

(h) $x^2(x + 3)$

Solution:

(a) $f(x) = x^2 - 9x$
 $f'(x) = 2x - 9$
 $f'(x) < 0 \Rightarrow 2x - 9 < 0$
 So $2x < 9$
 i.e. $x < 4.5$

(b) $f(x) = 5x - x^2$
 $f'(x) = 5 - 2x$
 $f'(x) < 0 \Rightarrow 5 - 2x < 0$
 So $5 < 2x$
 i.e. $2x > 5$
 $x > 2.5$

(c) $f(x) = 4 - 2x - x^2$
 $f'(x) = -2 - 2x$
 $f'(x) < 0 \Rightarrow -2 - 2x < 0$
 So $-2 < 2x$
 i.e. $2x > -2$
 $x > -1$

(d) $f(x) = 2x^3 - 3x^2 - 12x$
 $f'(x) = 6x^2 - 6x - 12$
 $f'(x) < 0 \Rightarrow 6x^2 - 6x - 12 < 0$
 So $6(x^2 - x - 2) < 0$
 i.e. $6(x - 2)(x + 1) < 0$
 By considering the 3 regions $x < -1$, $-1 < x < 2$, $x > 2$ determine
 $-1 < x < 2$

$$(e) f(x) = 1 - 27x + x^3$$

$$f'(x) = -27 + 3x^2$$

$$f'(x) < 0 \Rightarrow -27 + 3x^2 < 0$$

$$\text{So } 3x^2 < 27$$

$$\text{i.e. } x^2 < 9$$

$$-3 < x < 3$$

$$(f) f\left(x\right) = x + \frac{25}{x}$$

$$f'\left(x\right) = 1 - \frac{25}{x^2}$$

$$f'\left(x\right) < 0 \Rightarrow 1 - \frac{25}{x^2} < 0$$

$$\text{So } 1 < \frac{25}{x^2}$$

Multiply both sides by x^2 :

$$x^2 < 25$$

$$-5 < x < 5$$

$$(g) f\left(x\right) = x^{\frac{1}{2}} + 9x^{-\frac{1}{2}}$$

$$f'\left(x\right) = \frac{1}{2}x^{-\frac{1}{2}} - 9 \times \frac{1}{2}x^{-\frac{3}{2}}$$

$$f'\left(x\right) < 0 \Rightarrow \frac{1}{2}x^{-\frac{1}{2}} - \frac{9}{2}x^{-\frac{3}{2}} < 0$$

$$\text{So } \frac{x^{-\frac{3}{2}}}{2} \left(x - 9 \right) < 0$$

$x > 0$ or the function is not defined

$$\text{So } 0 < x < 9$$

$$(h) f(x) = x^3 + 3x^2$$

$$f'(x) = 3x^2 + 6x$$

$$f'(x) < 0 \Rightarrow 3x^2 + 6x < 0$$

$$\text{So } 3x(x + 2) < 0$$

Consider the regions $x < -2$, $-2 < x < 0$ and $x > 0$ to give

$$-2 < x < 0$$

Solutionbank C2

Edexcel Modular Mathematics for AS and A-Level

Differentiation

Exercise B, Question 1

Question:

Find the least value of each of the following functions:

(a) $f(x) = x^2 - 12x + 8$

(b) $f(x) = x^2 - 8x - 1$

(c) $f(x) = 5x^2 + 2x$

Solution:

(a) $f(x) = x^2 - 12x + 8$

$f'(x) = 2x - 12$

Put $f'(x) = 0$, then $2x - 12 = 0$, i.e. $x = 6$

$f(6) = 6^2 - 12 \times 6 + 8 = -28$

The least value of $f(x)$ is -28 .

(b) $f(x) = x^2 - 8x - 1$

$f'(x) = 2x - 8$

Put $f'(x) = 0$, then $2x - 8 = 0$, i.e. $x = 4$

$f(4) = 4^2 - 8 \times 4 - 1 = -17$

The minimum value of $f(x)$ is -17 .

(c) $f(x) = 5x^2 + 2x$

$f'(x) = 10x + 2$

Put $f'(x) = 0$, then $10x + 2 = 0$, i.e. $x = \frac{-2}{10}$ or $x = -\frac{1}{5}$

$$f\left(-\frac{1}{5}\right) = 5\left(-\frac{1}{5}\right)^2 + 2\left(-\frac{1}{5}\right) = \frac{5}{25} - \frac{2}{5} = -\frac{1}{5}$$

The least value of $f(x)$ is $-\frac{1}{5}$

Solutionbank C2

Edexcel Modular Mathematics for AS and A-Level

Differentiation

Exercise B, Question 2

Question:

Find the greatest value of each of the following functions:

(a) $f(x) = 10 - 5x^2$

(b) $f(x) = 3 + 2x - x^2$

(c) $f(x) = (6 + x)(1 - x)$

Solution:

(a) $f(x) = 10 - 5x^2$

$$f'(x) = -10x$$

Put $f'(x) = 0$, then $-10x = 0$, i.e. $x = 0$

$$f(0) = 10 - 5 \times 0^2 = 10$$

Maximum value of $f(x)$ is 10.

(b) $f(x) = 3 + 2x - x^2$

$$f'(x) = 2 - 2x$$

Put $f'(x) = 0$, then $2 - 2x = 0$, i.e. $x = 1$

$$f(1) = 3 + 2 - 1 = 4$$

The greatest value of $f(x)$ is 4.

(c) $f(x) = (6 + x)(1 - x) = 6 - 5x - x^2$

$$f'(x) = -5 - 2x$$

Put $f'(x) = 0$, then $-5 - 2x = 0$, i.e. $x = -2\frac{1}{2}$

$$f\left(-2\frac{1}{2}\right) = 3\frac{1}{2} \times 3\frac{1}{2} = 12\frac{1}{4}$$

The maximum value of $f(x)$ is $12\frac{1}{4}$.

Solutionbank C2

Edexcel Modular Mathematics for AS and A-Level

Differentiation

Exercise B, Question 3

Question:

Find the coordinates of the points where the gradient is zero on the curves with the given equations. Establish whether these points are maximum points, minimum points or points of inflexion, by considering the second derivative in each case.

(a) $y = 4x^2 + 6x$

(b) $y = 9 + x - x^2$

(c) $y = x^3 - x^2 - x + 1$

(d) $y = x(x^2 - 4x - 3)$

(e) $y = x + \frac{1}{x}$

(f) $y = x^2 + \frac{54}{x}$

(g) $y = x - 3\sqrt{x}$

(h) $y = x^{\frac{1}{2}}(x - 6)$

(i) $y = x^4 - 12x^2$

Solution:

(a) $y = 4x^2 + 6x$

$$\frac{dy}{dx} = 8x + 6$$

Put $\frac{dy}{dx} = 0$

Then $8x + 6 = 0$

$$8x = -6$$

$$x = -\frac{3}{4}$$

When $x = -\frac{3}{4}$, $y = 4\left(-\frac{3}{4}\right)^2 + 6\left(-\frac{3}{4}\right) = \frac{9}{4} - \frac{9}{2} = -\frac{9}{4}$

So $\left(-\frac{3}{4}, -\frac{9}{4}\right)$ is a point of zero gradient

$$\frac{d^2y}{dx^2} = 8 > 0$$

So $\left(-\frac{3}{4}, -\frac{9}{4}\right)$ is a minimum point

(b) $y = 9 + x - x^2$

$$\frac{dy}{dx} = 1 - 2x$$

Put $\frac{dy}{dx} = 0$

Then $1 - 2x = 0$

$$x = \frac{1}{2}$$

When $x = \frac{1}{2}, y = 9 + \frac{1}{2} - \left(\frac{1}{2}\right)^2 = 9\frac{1}{4}$

So $\left(\frac{1}{2}, 9\frac{1}{4}\right)$ is a point with zero gradient

$$\frac{d^2y}{dx^2} = -2 < 0$$

So $\left(\frac{1}{2}, 9\frac{1}{4}\right)$ is a maximum point

(c) $y = x^3 - x^2 - x + 1$

$$\frac{dy}{dx} = 3x^2 - 2x - 1$$

Put $\frac{dy}{dx} = 0$

Then $3x^2 - 2x - 1 = 0$

$$(3x + 1)(x - 1) = 0$$

$$x = -\frac{1}{3} \text{ or } x = 1$$

When $x = -\frac{1}{3}, y = \left(-\frac{1}{3}\right)^3 - \left(-\frac{1}{3}\right)^2 - \left(-\frac{1}{3}\right) + 1 = 1\frac{5}{27}$

When $x = 1, y = 1^3 - 1^2 - 1 + 1 = 0$

So $\left(-\frac{1}{3}, 1\frac{5}{27}\right)$ and $(1, 0)$ are points of zero gradient

$$\frac{d^2y}{dx^2} = 6x - 2$$

When $x = -\frac{1}{3}, \frac{d^2y}{dx^2} = -4 < 0$

So $\left(-\frac{1}{3}, 1\frac{5}{27}\right)$ is a maximum point

When $x = 1, \frac{d^2y}{dx^2} = 6 - 2 = 4 > 0$

So $(1, 0)$ is a minimum point

(d) $y = x(x^2 - 4x - 3) = x^3 - 4x^2 - 3x$

$$\frac{dy}{dx} = 3x^2 - 8x - 3$$

$$\text{Put } \frac{dy}{dx} = 0$$

$$\text{Then } 3x^2 - 8x - 3 = 0 \\ (3x + 1)(x - 3) = 0$$

$$x = -\frac{1}{3} \text{ or } 3$$

$$\text{When } x = -\frac{1}{3}, y = \left(-\frac{1}{3}\right)^3 - 4\left(-\frac{1}{3}\right)^2 - 3\left(-\frac{1}{3}\right) = \frac{14}{27}$$

$$\text{When } x = 3, y = 3^3 - 4 \times 3^2 - 3 \times 3 = -18$$

$$\text{So } \left(-\frac{1}{3}, -\frac{14}{27}\right) \text{ and } (3, -18) \text{ are points with zero gradient}$$

$$\frac{d^2y}{dx^2} = 6x - 8$$

$$\text{When } x = -\frac{1}{3}, \frac{d^2y}{dx^2} = -10 < 0$$

$$\text{So } \left(-\frac{1}{3}, -\frac{14}{27}\right) \text{ is a maximum point}$$

$$\text{When } x = 3, \frac{d^2y}{dx^2} = +10 > 0$$

$$\text{So } (3, -18) \text{ is a minimum point}$$

$$(e) y = x + \frac{1}{x} = x + x^{-1}$$

$$\frac{dy}{dx} = 1 - x^{-2}$$

$$\text{Put } \frac{dy}{dx} = 0$$

$$\text{Then } 1 - x^{-2} = 0$$

$$x^2 = 1$$

$$x = \pm 1$$

$$\text{When } x = 1, y = 1 + \frac{1}{1} = 2$$

$$\text{When } x = -1, y = -1 + \frac{1}{-1} = -2$$

$$\text{So } (1, 2) \text{ and } (-1, -2) \text{ are points with zero gradient}$$

$$\frac{d^2y}{dx^2} = 2x^{-3}$$

$$\text{When } x = 1, \frac{d^2y}{dx^2} = 2 > 0$$

$$\text{So } (1, 2) \text{ is a minimum point}$$

$$\text{When } x = -1, \frac{d^2y}{dx^2} = -2 < 0$$

$$\text{So } (-1, -2) \text{ is a maximum point}$$

$$(f) y = x^2 + \frac{54}{x} = x^2 + 54x^{-1}$$

$$\frac{dy}{dx} = 2x - 54x^{-2}$$

$$\text{Put } \frac{dy}{dx} = 0$$

$$\text{Then } 2x - 54x^{-2} = 0$$

$$2x = \frac{54}{x^2}$$

$$x^3 = 27$$

$$x = 3$$

$$\text{When } x = 3, y = 3^2 + \frac{54}{3} = 27$$

So (3, 27) is a point of zero gradient

$$\frac{d^2y}{dx^2} = 2 + 108x^{-3}$$

$$\text{When } x = 3, \frac{d^2y}{dx^2} = 6 > 0$$

So (3, 27) is a minimum point

$$\text{(g) } y = x - 3\sqrt{x} = x - 3x^{\frac{1}{2}}$$

$$\frac{dy}{dx} = 1 - \frac{3}{2}x^{-\frac{1}{2}}$$

$$\text{Put } \frac{dy}{dx} = 0$$

$$\text{Then } 1 - \frac{3}{2}x^{-\frac{1}{2}} = 0$$

$$1 = \frac{3}{2\sqrt{x}}$$

$$\sqrt{x} = \frac{3}{2}$$

$$x = \frac{9}{4}$$

$$\text{When } x = \frac{9}{4}, y = \frac{9}{4} - 3\sqrt{\frac{9}{4}} = \frac{-9}{4}$$

So $\left(\frac{9}{4}, \frac{-9}{4}\right)$ is a point with zero gradient

$$\frac{d^2y}{dx^2} = \frac{3}{4}x^{-\frac{3}{2}}$$

$$\text{When } x = \frac{9}{4}, \frac{d^2y}{dx^2} = \frac{3}{4} \times \left(\frac{9}{4}\right)^{-\frac{3}{2}} = \frac{3}{4} \times \left(\frac{2}{3}\right)^3 = \frac{2}{9} > 0$$

So $\left(\frac{9}{4}, \frac{-9}{4}\right)$ is a minimum point

$$\text{(h) } y = x^{\frac{1}{2}}(x - 6) = x^{\frac{3}{2}} - 6x^{\frac{1}{2}}$$

$$\frac{dy}{dx} = \frac{3}{2}x^{\frac{1}{2}} - 3x^{-\frac{1}{2}}$$

$$\text{Put } \frac{dy}{dx} = 0$$

$$\text{Then } \frac{3}{2}x^{\frac{1}{2}} - 3x^{-\frac{1}{2}} = 0$$

$$\frac{3}{2}x^{\frac{1}{2}} = \frac{3}{x^{\frac{1}{2}}}$$

Multiply both sides by $x^{\frac{1}{2}}$:

$$\frac{3}{2}x = 3$$

$$x = 2$$

$$\text{When } x = 2, y = 2^{\frac{1}{2}} \left(-4 \right) = -4\sqrt{2}$$

So $(2, -4\sqrt{2})$ is a point with zero gradient

$$\frac{d^2y}{dx^2} = \frac{3}{4}x^{-\frac{1}{2}} + \frac{3}{2}x^{-\frac{3}{2}}$$

$$\text{When } x = 2, \frac{d^2y}{dx^2} = \frac{3}{4\sqrt{2}} + \frac{3}{4\sqrt{2}} > 0$$

So $(2, -4\sqrt{2})$ is a minimum point

$$(i) y = x^4 - 12x^2$$

$$\frac{dy}{dx} = 4x^3 - 24x$$

$$\text{Put } \frac{dy}{dx} = 0$$

$$\text{Then } 4x^3 - 24x = 0$$

$$4x(x^2 - 6) = 0$$

$$x = 0 \text{ or } x = \pm\sqrt{6}$$

$$\text{When } x = 0, y = 0$$

$$\text{When } x = \pm\sqrt{6}, y = -36$$

So $(0, 0)$, $(\sqrt{6}, -36)$ and $(-\sqrt{6}, -36)$ are points with zero gradient

$$\frac{d^2y}{dx^2} = 12x^2 - 24$$

$$\text{When } x = 0, \frac{d^2y}{dx^2} = -24 < 0$$

So $(0, 0)$ is a maximum point

$$\text{When } x^2 = 6, \frac{d^2y}{dx^2} = 48 > 0$$

So $(\sqrt{6}, -36)$ and $(-\sqrt{6}, -36)$ are minimum points

Solutionbank C2

Edexcel Modular Mathematics for AS and A-Level

Differentiation
Exercise B, Question 4

Question:

Sketch the curves with equations given in question 3 parts (a), (b), (c) and (d) labelling any stationary values.

Solution:

(a)

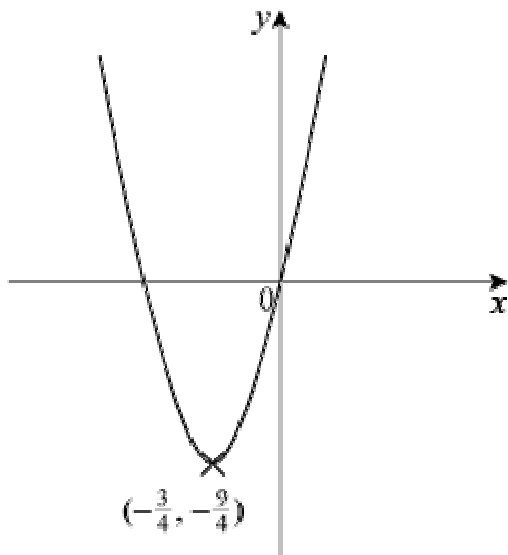

(b)

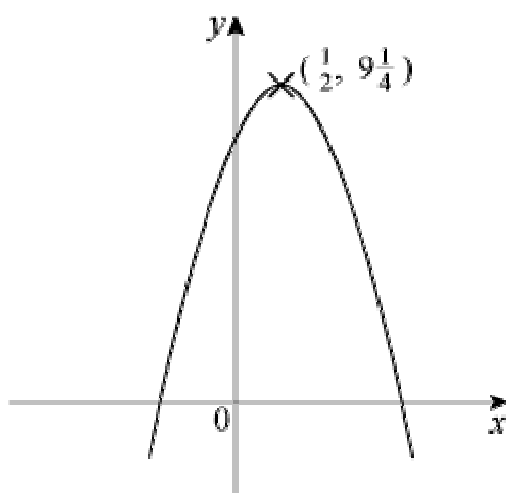

(c)

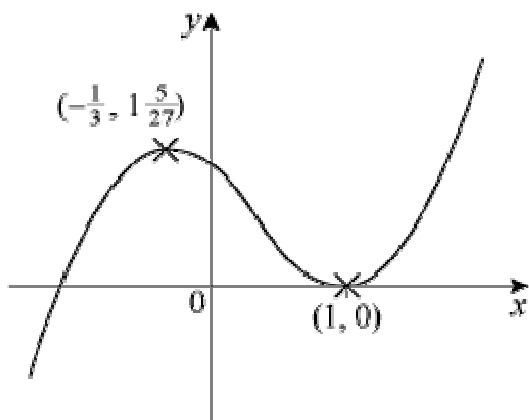

(d)

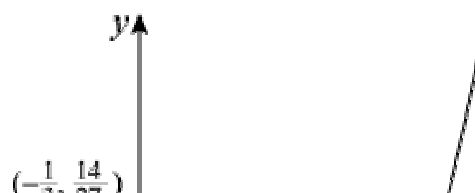

© Pearson Education Ltd 2008

Solutionbank C2

Edexcel Modular Mathematics for AS and A-Level

Differentiation

Exercise B, Question 5

Question:

By considering the gradient on either side of the stationary point on the curve $y = x^3 - 3x^2 + 3x$, show that this point is a point of inflexion.

Sketch the curve $y = x^3 - 3x^2 + 3x$.

Solution:

$$y = x^3 - 3x^2 + 3x$$

$$\frac{dy}{dx} = 3x^2 - 6x + 3$$

$$\text{Put } \frac{dy}{dx} = 0$$

$$\text{Then } 3x^2 - 6x + 3 = 0$$

$$3(x^2 - 2x + 1) = 0$$

$$3(x - 1)^2 = 0$$

$$x = 1$$

$$\text{when } x = 1, y = 1$$

So (1, 1) is a point with zero gradient.

Consider points near to (1, 1) and find the gradient at these points.

x	0.9	1	1.1
$\frac{dy}{dx}$	0.03	0	0.03
	+ve /	0 —	+ve /

The gradient on either side of (1, 1) is positive.

This is *not* a turning point—it is a point of inflexion.

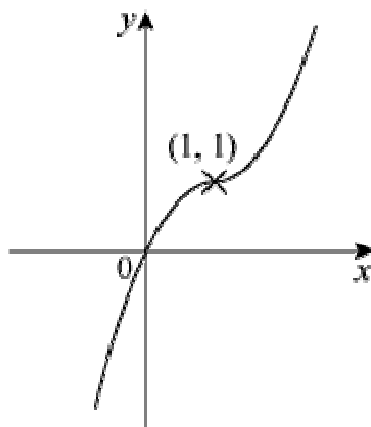

Solutionbank C2

Edexcel Modular Mathematics for AS and A-Level

Differentiation

Exercise B, Question 6

Question:

Find the maximum value and hence the range of values for the function $f(x) = 27 - 2x^4$.

Solution:

$$f(x) = 27 - 2x^4$$

$$f'(x) = -8x^3$$

$$\text{Put } f'(x) = 0$$

$$\text{Then } -8x^3 = 0$$

$$\text{So } x = 0$$

$$f(0) = 27$$

So $(0, 27)$ is a point of zero gradient

$$f''(x) = -24x^2$$

$$f''(0) = 0 \text{ —not conclusive}$$

Find gradient on either side of $(0, 27)$:

x	-0.1	0	0.1
$\frac{dy}{dx}$	+0.008	0	-0.008
	↗	—	↘

There is a maximum turning point at $(0, 27)$.

So the maximum value of $f(x)$ is 27 and range of values is $f(x) \leq 27$.

Solutionbank C2

Edexcel Modular Mathematics for AS and A-Level

Differentiation

Exercise C, Question 1

Question:

A rectangular garden is fenced on three sides, and the house forms the fourth side of the rectangle.

Given that the total length of the fence is 80 m show that the area, A , of the garden is given by the formula $A = y(80 - 2y)$, where y is the distance from the house to the end of the garden.

Given that the area is a maximum for this length of fence, find the dimensions of the enclosed garden, and the area which is enclosed.

Solution:

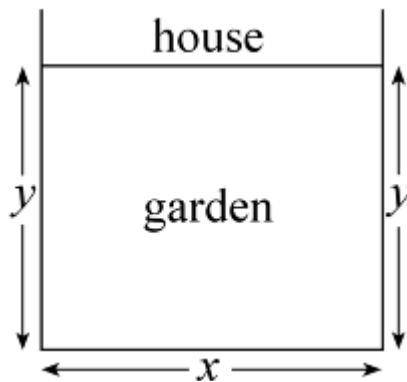

Let the width of the garden be x m.

Then $x + 2y = 80$

So $x = 80 - 2y$ *

Area $A = xy$

So $A = y(80 - 2y)$

$$A = 80y - 2y^2$$

$$\frac{dA}{dy} = 80 - 4y$$

Put $\frac{dA}{dy} = 0$ for maximum area

$$\text{Then } 80 - 4y = 0$$

$$\text{So } y = 20$$

Substitute in * to give $x = 40$.

$$\text{So area} = 40 \text{ m} \times 20 \text{ m} = 800 \text{ m}^2$$

Solutionbank C2

Edexcel Modular Mathematics for AS and A-Level

Differentiation

Exercise C, Question 2

Question:

A closed cylinder has total surface area equal to 600π . Show that the volume, $V \text{ cm}^3$, of this cylinder is given by the formula $V = 300\pi r - \pi r^3$, where $r \text{ cm}$ is the radius of the cylinder.
Find the maximum volume of such a cylinder.

Solution:

$$\text{Total surface area} = 2\pi rh + 2\pi r^2$$

$$\text{So } 2\pi rh + 2\pi r^2 = 600\pi$$

$$rh = 300 - r^2$$

$$\text{Volume} = \pi r^2 h = \pi r (rh) = \pi r (300 - r^2)$$

$$\text{So } V = 300\pi r - \pi r^3$$

$$\text{For maximum volume } \frac{dV}{dr} = 0$$

$$\frac{dV}{dr} = 300\pi - 3\pi r^2$$

$$\text{Put } \frac{dV}{dr} = 0$$

$$\text{Then } 300\pi - 3\pi r^2 = 0$$

$$\text{So } r^2 = 100$$

$$r = 10$$

Substitute $r = 10$ into V to give

$$V = 300\pi \times 10 - \pi \times 10^3 = 2000\pi$$

$$\text{Maximum volume} = 2000\pi \text{ cm}^3$$

Solutionbank C2

Edexcel Modular Mathematics for AS and A-Level

Differentiation

Exercise C, Question 3

Question:

A sector of a circle has area 100 cm^2 . Show that the perimeter of this sector is given by the formula $P = 2r + \frac{200}{r}$, $r > \sqrt{\frac{100}{\pi}}$.

Find the minimum value for the perimeter of such a sector.

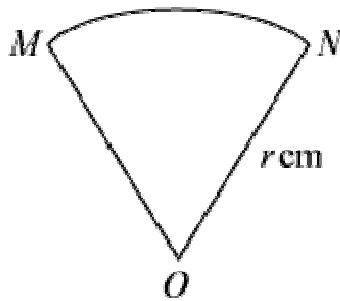

Solution:

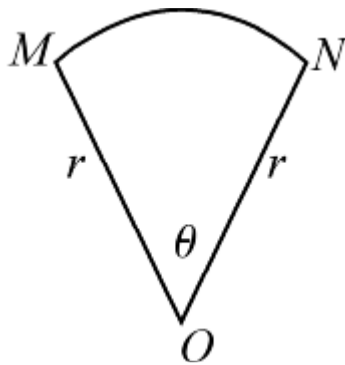

Let angle $MON = \theta$ radians.

Then perimeter $P = 2r + r\theta$ ①

and area $A = \frac{1}{2}r^2\theta$

But area is 100 cm^2 so

$$\frac{1}{2}r^2\theta = 100$$

$$r\theta = \frac{200}{r}$$

Substitute into ① to give

$$P = 2r + \frac{200}{r} \quad \text{②}$$

Since area of circle $>$ area of sector

$$\pi r^2 > 100$$

$$\text{So } r > \sqrt{\frac{100}{\pi}}$$

For the minimum perimeter $\frac{dP}{dr} = 0$

$$\frac{dP}{dr} = 2 - \frac{200}{r^2}$$

Put $\frac{dP}{dr} = 0$

Then $2 - \frac{200}{r^2} = 0$

So $r = 10$

Substitute into ② to give $P = 20 + 20 = 40$

Minimum perimeter = 40 cm

© Pearson Education Ltd 2008

Solutionbank C2

Edexcel Modular Mathematics for AS and A-Level

Differentiation

Exercise C, Question 4

Question:

A shape consists of a rectangular base with a semicircular top, as shown. Given that the perimeter of the shape is 40 cm, show that its area, A cm², is given by the formula

$$A = 40r - 2r^2 - \frac{\pi r^2}{2}$$

where r cm is the radius of the semicircle. Find the maximum value for this area.

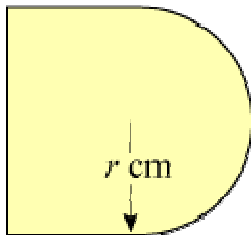

Solution:

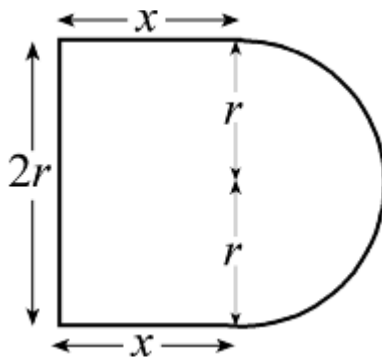

Let the rectangle have dimensions $2r$ by x cm.

Then perimeter of figure is

$$(2r + 2x + \pi r) \text{ cm}$$

But perimeter is 40 cm so

$$2r + 2x + \pi r = 40$$

$$x = \frac{40 - \pi r - 2r}{2} \quad *$$

$$\text{Area} = 2rx + \frac{1}{2}\pi r^2 \text{ (rectangle + semicircle)}$$

$$\text{So } A = r \left(40 - \pi r - 2r \right) + \frac{1}{2}\pi r^2 \text{ (substituting from *)}$$

$$\Rightarrow A = 40r - 2r^2 - \frac{1}{2}\pi r^2$$

To find maximum value, put $\frac{dA}{dr} = 0$:

$$40 - 4r - \pi r = 0$$

$$r = \frac{40}{4 + \pi}$$

Substitute into expression for A :

$$A = 40 \times \frac{40}{4 + \pi} - 2 \left(\frac{40}{4 + \pi} \right)^2 - \frac{1}{2} \pi \left(\frac{40}{4 + \pi} \right)^2$$

$$A = \frac{1600}{4 + \pi} - \left(2 + \frac{1}{2} \pi \right) \left(\frac{40}{4 + \pi} \right)^2$$

$$A = \frac{1600}{4 + \pi} - \frac{4 + \pi}{2} \times \frac{1600}{(4 + \pi)^2}$$

$$A = \frac{1600}{4 + \pi} - \frac{800}{4 + \pi}$$

$$A = \frac{800}{4 + \pi} \text{ cm}^2$$

© Pearson Education Ltd 2008

Solutionbank C2

Edexcel Modular Mathematics for AS and A-Level

Differentiation

Exercise C, Question 5

Question:

The shape shown is a wire frame in the form of a large rectangle split by parallel lengths of wire into 12 smaller equal-sized rectangles.

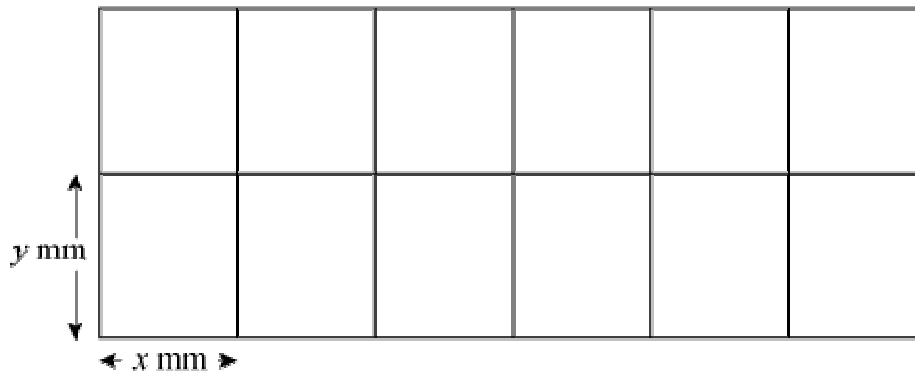

Given that the total length of wire used to complete the whole frame is 1512 mm, show that the area of the whole shape is A mm², where $A = 1296x - \frac{108x^2}{7}$, where x mm is the width of one of the smaller rectangles.

Find the maximum area which can be enclosed in this way.

Solution:

Total length of wire is $(18x + 14y)$ mm

But length = 1512 mm so

$$18x + 14y = 1512$$

$$y = \frac{1512 - 18x}{14} \quad \text{①}$$

Total area A mm² is given by

$$A = 2y \times 6x \quad \text{②}$$

Substitute ① into ② to give

$$A = 12x \left(\frac{1512 - 18x}{14} \right)$$

$$A = 1296x - \frac{108}{7}x^2 \quad *$$

For maximum area, put $\frac{dA}{dx} = 0$:

$$\frac{dA}{dx} = 1296 - \frac{216}{7}x$$

$$\text{when } \frac{dA}{dx} = 0, x = \frac{7 \times 1296}{216} = 42$$

Substitute $x = 42$ into $*$ to give $A = 27216$

Maximum area = 27216 mm²

$$\text{(Check: } \frac{d^2A}{dx^2} = -\frac{216}{7} < 0 \therefore \text{maximum)}$$

Solutionbank C2

Edexcel Modular Mathematics for AS and A-Level

Differentiation

Exercise D, Question 1

Question:

Given that: $y = x^{\frac{3}{2}} + \frac{48}{x}$ $\left(x > 0 \right)$

(a) Find the value of x and the value of y when $\frac{dy}{dx} = 0$.

(b) Show that the value of y which you found in (a) is a minimum. **[E]**

Solution:

Given that $y = x^{\frac{3}{2}} + \frac{48}{x}$ $\left(x > 0 \right)$

(a) $\frac{dy}{dx} = \frac{3}{2}x^{\frac{1}{2}} - \frac{48}{x^2}$

Put $\frac{dy}{dx} = 0$:

$$\frac{3}{2}x^{\frac{1}{2}} = \frac{48}{x^2}$$

$$x^2 \cdot \frac{1}{2} = 32$$

$$x = 4$$

Substitute $x = 4$ into $y = x^{\frac{3}{2}} + \frac{48}{x}$ to give

$$y = 8 + 12 = 20$$

So $x = 4$ and $y = 20$ when $\frac{dy}{dx} = 0$

(b) $\frac{d^2y}{dx^2} = \frac{3}{4}x^{-\frac{1}{2}} + \frac{96}{x^3}$

When $x = 4$, $\frac{d^2y}{dx^2} = \frac{3}{8} + \frac{96}{64} = \frac{15}{8} > 0 \therefore$ minimum

Solutionbank C2

Edexcel Modular Mathematics for AS and A-Level

Differentiation

Exercise D, Question 2

Question:

A curve has equation $y = x^3 - 5x^2 + 7x - 14$. Determine, by calculation, the coordinates of the stationary points of the curve C .

[E]

Solution:

$$y = x^3 - 5x^2 + 7x - 14$$

$$\frac{dy}{dx} = 3x^2 - 10x + 7$$

$$\text{When } \frac{dy}{dx} = 0$$

$$3x^2 - 10x + 7 = 0$$
$$(3x - 7)(x - 1) = 0$$

$$x = \frac{7}{3} \text{ or } x = 1$$

$$\text{When } x = \frac{7}{3}, y = -12 \frac{5}{27}$$

$$\text{When } x = 1, y = -11$$

So $\left(\frac{7}{3}, -12 \frac{5}{27}\right)$ and $(1, -11)$ are stationary points (where the gradient is zero)

Solutionbank C2

Edexcel Modular Mathematics for AS and A-Level

Differentiation

Exercise D, Question 3

Question:

The function f , defined for $x \in \mathbb{R}, x > 0$, is such that:

$$f' \left(x \right) = x^2 - 2 + \frac{1}{x^2}$$

- (a) Find the value of $f''(x)$ at $x = 4$.
- (b) Given that $f(3) = 0$, find $f(x)$.
- (c) Prove that f is an increasing function.

[E]

Solution:

$$f' \left(x \right) = x^2 - 2 + \frac{1}{x^2} \quad \left(x > 0 \right)$$

$$(a) f'' \left(x \right) = 2x - \frac{2}{x^3}$$

$$\text{At } x = 4, f'' \left(x \right) = 7 \frac{31}{32}$$

$$(b) f \left(x \right) = \frac{x^3}{3} - 2x - \frac{1}{x} + c$$

$$f \left(3 \right) = 0 \Rightarrow \frac{3^3}{3} - 2 \times 3 - \frac{1}{3} + c = 0$$

$$\Rightarrow c = -2 \frac{2}{3}$$

$$\text{So } f \left(x \right) = \frac{x^3}{3} - 2x - \frac{1}{x} - 2 \frac{2}{3}$$

- (c) For an increasing function, $f'(x) > 0$

$$\Rightarrow x^2 - 2 + \frac{1}{x^2} > 0$$

$$\Rightarrow \left(x - \frac{1}{x} \right)^2 > 0$$

This is true for all x , except $x = 1$ [where $f'(1) = 0$].
So the function is an increasing function.

Solutionbank C2

Edexcel Modular Mathematics for AS and A-Level

Differentiation

Exercise D, Question 4

Question:

A curve has equation $y = x^3 - 6x^2 + 9x$.
Find the coordinates of its maximum turning point.

[E]

Solution:

$$y = x^3 - 6x^2 + 9x$$

$$\frac{dy}{dx} = 3x^2 - 12x + 9$$

$$\text{Put } \frac{dy}{dx} = 0$$

$$\text{Then } 3x^2 - 12x + 9 = 0$$

$$3(x^2 - 4x + 3) = 0$$

$$3(x - 1)(x - 3) = 0$$

$$x = 1 \text{ or } x = 3$$

$$\frac{d^2y}{dx^2} = 6x - 12$$

When $x = 1$, $\frac{d^2y}{dx^2} = -6 < 0 \therefore$ maximum point

When $x = 3$, $\frac{d^2y}{dx^2} = +6 > 0 \therefore$ minimum point

So the maximum point is where $x = 1$.

Substitute $x = 1$ into $y = x^3 - 6x^2 + 9x$

$$\text{Then } y = 1 - 6 + 9 = 4$$

So $(1, 4)$ is the maximum turning point.

Solutionbank C2

Edexcel Modular Mathematics for AS and A-Level

Differentiation

Exercise D, Question 5

Question:

A wire is bent into the plane shape $ABCDEA$ as shown. Shape $ABDE$ is a rectangle and BCD is a semicircle with diameter BD . The area of the region enclosed by the wire is $R \text{ m}^2$, $AE = x$ metres, $AB = ED = y$ metres. The total length of the wire is 2 m.

(a) Find an expression for y in terms of x .

(b) Prove that $R = \frac{x}{8} \left(8 - 4x - \pi x \right)$

Given that x can vary, using calculus and showing your working,

(c) find the maximum value of R . (You do not have to prove that the value you obtain is a maximum.)

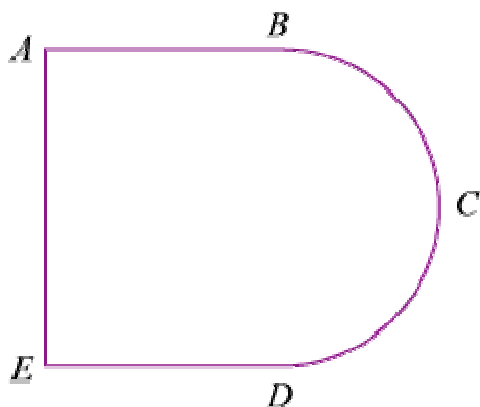

[E]

Solution:

(a) The total length of wire is $\left(2y + x + \frac{\pi x}{2} \right)$ m

As total length is 2 m so

$$2y + x \left(1 + \frac{\pi}{2} \right) = 2$$

$$y = 1 - \frac{1}{2}x \left(1 + \frac{\pi}{2} \right) \quad \text{①}$$

(b) Area $R = xy + \frac{1}{2}\pi \left(\frac{x}{2} \right)^2$

Substitute from ① to give

$$R = x \left(1 - \frac{1}{2}x - \frac{\pi}{4}x \right) + \frac{\pi}{8}x^2$$

$$R = \frac{x}{8} \left(8 - 4x - 2\pi x + \pi x \right)$$

$$R = \frac{x}{8} \left(8 - 4x - \pi x \right) \quad \textcircled{2}$$

(c) For maximum R , $\frac{dR}{dx} = 0$

$$R = x - \frac{1}{2}x^2 - \frac{\pi}{8}x^2$$

$$\text{So } \frac{dR}{dx} = 1 - x - \frac{\pi}{4}x$$

$$\text{Put } \frac{dR}{dx} = 0 \text{ to obtain } x = \frac{1}{1 + \frac{\pi}{4}}$$

$$\text{So } x = \frac{4}{4 + \pi}$$

Substitute into $\textcircled{2}$ to give

$$R = \frac{1}{2(4 + \pi)} \left(8 - \frac{16}{4 + \pi} - \frac{4\pi}{4 + \pi} \right)$$

$$R = \frac{1}{2(4 + \pi)} \times \frac{32 + 8\pi - 16 - 4\pi}{4 + \pi}$$

$$R = \frac{1}{2(4 + \pi)} \times \frac{16 + 4\pi}{4 + \pi}$$

$$R = \frac{4(4 + \pi)}{2(4 + \pi)^2}$$

$$R = \frac{2}{4 + \pi}$$

© Pearson Education Ltd 2008

Solutionbank C2

Edexcel Modular Mathematics for AS and A-Level

Differentiation

Exercise D, Question 6

Question:

The fixed point A has coordinates $(8, -6, 5)$ and the variable point P has coordinates $(t, t, 2t)$.

- (a) Show that $AP^2 = 6t^2 - 24t + 125$.
- (b) Hence find the value of t for which the distance AP is least.
- (c) Determine this least distance.

[E]

Solution:

(a) From Pythagoras

$$AP^2 = (8 - t)^2 + (-6 - t)^2 + (5 - 2t)^2$$

$$AP^2 = 64 - 16t + t^2 + 36 + 12t + t^2 + 25 - 20t + 4t^2$$

$$AP^2 = 6t^2 - 24t + 125 \quad *$$

(b) AP is least when AP^2 is least.

$$\frac{d(AP^2)}{dt} = 12t - 24$$

$$\text{Put } \frac{d(AP^2)}{dt} = 0, \text{ then } t = 2$$

(c) Substitute $t = 2$ into $*$ to obtain

$$AP^2 = 24 - 48 + 125 = 101$$

$$\text{So } AP = \sqrt{101}$$

Solutionbank C2

Edexcel Modular Mathematics for AS and A-Level

Differentiation

Exercise D, Question 7

Question:

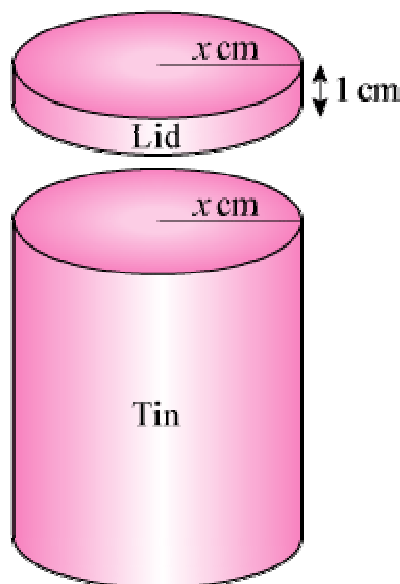

A cylindrical biscuit tin has a close-fitting lid which overlaps the tin by 1 cm, as shown. The radii of the tin and the lid are both x cm. The tin and the lid are made from a thin sheet of metal of area $80\pi\text{cm}^2$ and there is no wastage. The volume of the tin is $V\text{cm}^3$.

(a) Show that $V = \pi (40x - x^2 - x^3)$.
Given that x can vary:

- (b) Use differentiation to find the positive value of x for which V is stationary.
- (c) Prove that this value of x gives a maximum value of V .
- (d) Find this maximum value of V .
- (e) Determine the percentage of the sheet metal used in the lid when V is a maximum.

[E]

Solution:

(a) Let the height of the tin be h cm.

The area of the curved surface of the tin = $2\pi xh\text{cm}^2$

The area of the base of the tin = $\pi x^2\text{cm}^2$

The area of the curved surface of the lid = $2\pi x\text{cm}^2$

The area of the top of the lid = $\pi x^2\text{cm}^2$

Total area of sheet metal is $80\pi\text{cm}^2$

So $2\pi x^2 + 2\pi x + 2\pi xh = 80\pi$

Rearrange to give

$$h = \frac{40 - x - x^2}{x}$$

The volume, V , of the tin is given by

$$V = \pi x^2 h$$

$$\text{So } V = \frac{\pi x^2 (40 - x - x^2)}{x} = \pi \left(40x - x^2 - x^3 \right)$$

$$\text{(b) } \frac{dV}{dx} = \pi \left(40 - 2x - 3x^2 \right)$$

When V is stationary $\frac{dV}{dx} = 0$

$$\text{So } 40 - 2x - 3x^2 = 0$$

$$\Rightarrow (10 - 3x)(4 + x) = 0$$

$$\Rightarrow x = \frac{10}{3} \text{ or } -4$$

But x is positive so $x = \frac{10}{3}$ is the required value.

$$\text{(c) } \frac{d^2V}{dx^2} = \pi \left(-2 - 6x \right)$$

$$\text{When } x = \frac{10}{3}, \frac{d^2V}{dx^2} = \pi \left(-2 - 20 \right) < 0$$

So V has a maximum value.

(d) Substitute $x = \frac{10}{3}$ into the expression given in part (a):

$$V = \frac{2300\pi}{27}$$

(e) The metal used in the lid = $2\pi x + \pi x^2$ with $x = \frac{10}{3}$

$$\text{i.e. } A_{\text{lid}} = \frac{160\pi}{9}$$

$$\text{Total area} = 80\pi$$

$$\text{So percentage used in the lid} = \left(\frac{\frac{160\pi}{9} \div 80\pi}{1} \right) \times 100 = 22 \frac{2}{9} \% .$$

Solutionbank C2

Edexcel Modular Mathematics for AS and A-Level

Differentiation

Exercise D, Question 8

Question:

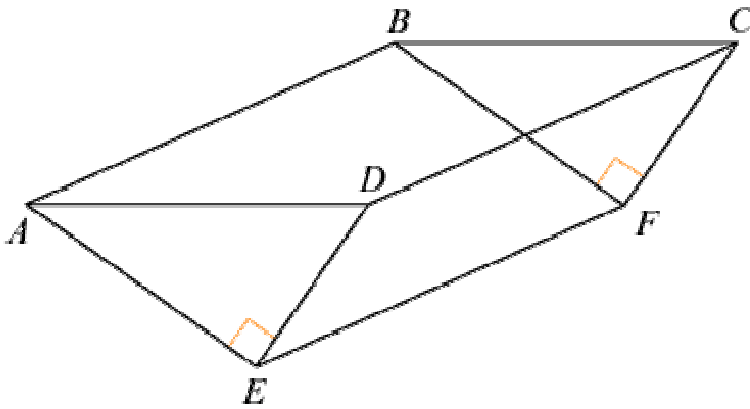

The diagram shows an open tank for storing water, $ABCDEF$. The sides $ABFE$ and $CDEF$ are rectangles. The triangular ends ADE and BCF are isosceles, and $\angle AED = \angle BFC = 90^\circ$. The ends ADE and BCF are vertical and EF is horizontal.

Given that $AD = x$ metres:

(a) show that the area of triangle ADE is $\frac{1}{4}x^2 \text{ m}^2$.

Given also that the capacity of the container is 4000 m^3 and that the total area of the two triangular and two rectangular sides of the container is $S \text{ m}^2$:

(b) Show that $S = \frac{x^2}{2} + \frac{16000\sqrt{2}}{x}$.

Given that x can vary:

(c) Use calculus to find the minimum value of S .

(d) Justify that the value of S you have found is a minimum.

[E]

Solution:

(a) Let the equal sides of $\triangle ADE$ be a metres.

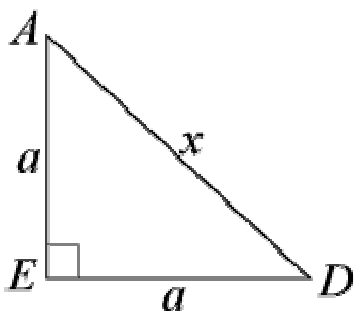

Then $a^2 + a^2 = x^2$ (Pythagoras' Theorem)

$$\text{So } 2a^2 = x^2$$

$$\Rightarrow a^2 = \frac{x^2}{2}$$

$$\text{Area of } \triangle ADE = \frac{1}{2} \text{base} \times \text{height} = \frac{1}{2} a \times a = \frac{x^2}{4}$$

$$\text{(b) Area of two triangular sides is } 2 \times \frac{x^2}{4} = \frac{x^2}{2}$$

Let the length $AB = CD = y$ metres

$$\text{Area of two rectangular sides is } 2 \times ay = 2ay = 2 \sqrt{\frac{x^2}{2}} y$$

$$\text{Then } S = \frac{x^2}{2} + 2 \sqrt{\frac{x^2}{2}} y \quad *$$

But capacity of storage tank is $\frac{1}{4}x^2 \times y$ so

$$\frac{1}{4}x^2 y = 4000$$

$$y = \frac{16000}{x^2}$$

Substitute this into equation * to give

$$S = \frac{x^2}{2} + \frac{16000\sqrt{2}}{x}$$

$$\text{(c) } \frac{dS}{dx} = x - \frac{16000\sqrt{2}}{x^2}$$

$$\text{Put } \frac{dS}{dx} = 0$$

$$\text{Then } x - \frac{16000\sqrt{2}}{x^2} = 0$$

$$x = \frac{16000\sqrt{2}}{x^2}$$

$$x^3 = 16000\sqrt{2}$$

$$x = 20\sqrt{2} \text{ or } 28.28$$

Substitute into expression for S to give

$$S = 400 + 800 = 1200$$

$$\text{(d) } \frac{d^2S}{dx^2} = 1 + \frac{32000\sqrt{2}}{x^3}$$

When $x = 20\sqrt{2}$, $\frac{d^2S}{dx^2} = 3 > 0 \therefore$ minimum value

Solutionbank C2

Edexcel Modular Mathematics for AS and A-Level

Differentiation

Exercise D, Question 9

Question:

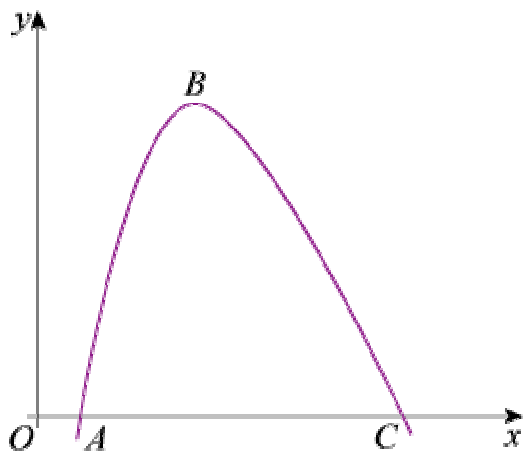

The diagram shows part of the curve with equation $y = f(x)$, where:

$$f(x) \equiv 200 - \frac{250}{x} - x^2, x > 0$$

The curve cuts the x -axis at the points A and C .

The point B is the maximum point of the curve.

- (a) Find $f'(x)$.
- (b) Use your answer to part (a) to calculate the coordinates of B .

[E]

Solution:

$$(a) f(x) = 200 - \frac{250}{x} - x^2$$

$$f'(x) = \frac{250}{x^2} - 2x$$

(b) At the maximum point, B , $f'(x) = 0$. So

$$\frac{250}{x^2} - 2x = 0$$

$$\frac{250}{x^2} = 2x$$

$$250 = 2x^3$$

$$x^3 = 125$$

$$x = 5 \text{ at point } B$$

As $y = f(x)$, $y = f(5)$ at point B . So $y = 125$.

The coordinates of B are $(5, 125)$.

Solutionbank C2

Edexcel Modular Mathematics for AS and A-Level

Differentiation

Exercise D, Question 10

Question:

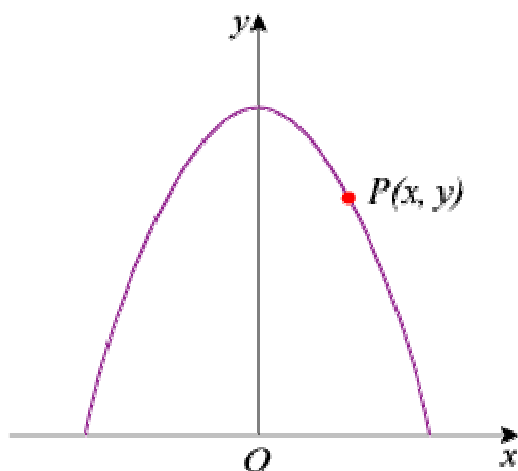

The diagram shows the part of the curve with equation $y = 5 - \frac{1}{2}x^2$ for which $y \geq 0$.

The point $P(x, y)$ lies on the curve and O is the origin.

(a) Show that $OP^2 = \frac{1}{4}x^4 - 4x^2 + 25$.

Taking $f \left(x \right) \equiv \frac{1}{4}x^4 - 4x^2 + 25$:

(b) Find the values of x for which $f' (x) = 0$.

(c) Hence, or otherwise, find the minimum distance from O to the curve, showing that your answer is a minimum.

[E]

Solution:

(a) P has coordinates $\left(x, 5 - \frac{1}{2}x^2 \right)$. So

$$OP^2 = (x - 0)^2 + \left(5 - \frac{1}{2}x^2 - 0 \right)^2 = x^2 + 25 - 5x^2 + \frac{1}{4}x^4 = \frac{1}{4}x^4 - 4x^2 + 25$$

(b) Given $f \left(x \right) = \frac{1}{4}x^4 - 4x^2 + 25$

$$f' (x) = x^3 - 8x$$

$$\text{When } f' (x) = 0 ,$$

$$x^3 - 8x = 0$$

$$x (x^2 - 8) = 0$$

$$x = 0 \text{ or } x^2 = 8$$

$$x = 0 \text{ or } x = \pm 2\sqrt{2}$$

(c) Substitute $x^2 = 8$ into $f(x)$:

$$OP^2 = \frac{1}{4} \times 8^2 - 4 \times 8 + 25 = 9$$

So $OP = 3$ when $x = \pm 2\sqrt{2}$

$f''(x) = 3x^2 - 8 = 16 > 0$ when $x^2 = 8 \Rightarrow$ minimum value for OP^2 and hence OP .

So minimum distance from O to the curve is 3.

© Pearson Education Ltd 2008

Solutionbank C2

Edexcel Modular Mathematics for AS and A-Level

Differentiation

Exercise D, Question 11

Question:

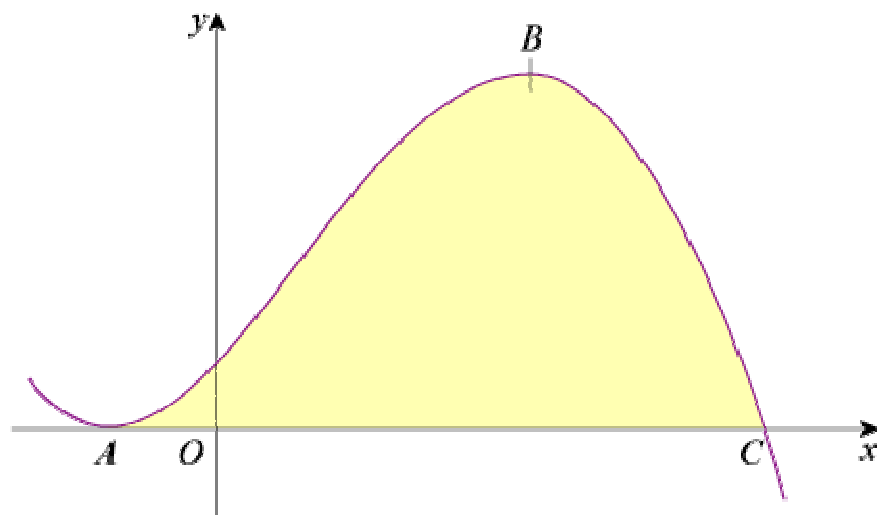

The diagram shows part of the curve with equation $y = 3 + 5x + x^2 - x^3$. The curve touches the x -axis at A and crosses the x -axis at C . The points A and B are stationary points on the curve.

(a) Show that C has coordinates $(3, 0)$.

(b) Using calculus and showing all your working, find the coordinates of A and B .

Solution:

(a) $y = 3 + 5x + x^2 - x^3$

Let $y = 0$, then

$$3 + 5x + x^2 - x^3 = 0$$

$$(3 - x)(1 + 2x + x^2) = 0$$

$$(3 - x)(1 + x)^2 = 0$$

$$x = 3 \text{ or } x = -1 \text{ when } y = 0$$

The curve touches the x -axis at $x = -1$ (A) and cuts the axis at $x = 3$ (C).

C has coordinates $(3, 0)$

(b) $\frac{dy}{dx} = 5 + 2x - 3x^2$

Put $\frac{dy}{dx} = 0$, then

$$5 + 2x - 3x^2 = 0$$

$$(5 - 3x)(1 + x) = 0$$

$$x = \frac{5}{3} \text{ or } x = -1$$

$$\text{When } x = \frac{5}{3}, y = 3 + 5 \left(\frac{5}{3} \right) + \left(\frac{5}{3} \right)^2 - \left(\frac{5}{3} \right)^3 = 9 \frac{13}{27}$$

So $\left(\frac{5}{3}, 9 \frac{13}{27} \right)$ is the point B .

When $x = -1, y = 0$

So $(-1, 0)$ is the point A.

© Pearson Education Ltd 2008

Solutionbank C2

Edexcel Modular Mathematics for AS and A-Level

Trigonometrical identities and simple equations

Exercise A, Question 1

Question:

Simplify each of the following expressions:

(a) $1 - \cos^2 \frac{1}{2}\theta$

(b) $5 \sin^2 3\theta + 5 \cos^2 3\theta$

(c) $\sin^2 A - 1$

(d) $\frac{\sin \theta}{\tan \theta}$

(e) $\frac{\sqrt{1 - \cos^2 x^\circ}}{\cos x^\circ}$

(f) $\frac{\sqrt{1 - \cos^2 3A}}{\sqrt{1 - \sin^2 3A}}$

(g) $(1 + \sin x)^2 + (1 - \sin x)^2 + 2 \cos^2 x$

(h) $\sin^4 \theta + \sin^2 \theta \cos^2 \theta$

(i) $\sin^4 \theta + 2 \sin^2 \theta \cos^2 \theta + \cos^4 \theta$

Solution:

(a) As $\sin^2 \frac{1}{2}\theta + \cos^2 \frac{1}{2}\theta \equiv 1$

So $1 - \cos^2 \frac{1}{2}\theta = \sin^2 \frac{1}{2}\theta$

(b) As $\sin^2 3\theta + \cos^2 3\theta \equiv 1$

So $5 \sin^2 3\theta + 5 \cos^2 3\theta = 5 (\sin^2 3\theta + \cos^2 3\theta) = 5$

(c) As $\sin^2 A + \cos^2 A \equiv 1$

So $\sin^2 A - 1 \equiv -\cos^2 A$

(d) $\frac{\sin \theta}{\tan \theta} = \frac{\sin \theta}{\frac{\sin \theta}{\cos \theta}}$

$= \sin \theta \times \frac{\cos \theta}{\sin \theta}$

$$= \cos \theta$$

$$(e) \frac{\sqrt{1 - \cos^2 x^\circ}}{\cos x^\circ} = \frac{\sqrt{\sin^2 x^\circ}}{\cos x^\circ} = \frac{\sin x^\circ}{\cos x^\circ} = \tan x^\circ$$

$$(f) \frac{\sqrt{1 - \cos^2 3A}}{\sqrt{1 - \sin^2 3A}} = \frac{\sqrt{\sin^2 3A}}{\sqrt{\cos^2 3A}} = \frac{\sin 3A}{\cos 3A} = \tan 3A$$

$$\begin{aligned} (g) & (1 + \sin x^\circ)^2 + (1 - \sin x^\circ)^2 + 2 \cos^2 x^\circ \\ &= 1 + 2 \sin x^\circ + \sin^2 x^\circ + 1 - 2 \sin x^\circ + \sin^2 x^\circ + 2 \cos^2 x^\circ \\ &= 2 + 2 \sin^2 x^\circ + 2 \cos^2 x^\circ \\ &= 2 + 2 (\sin^2 x^\circ + \cos^2 x^\circ) \\ &= 2 + 2 \\ &= 4 \end{aligned}$$

$$(h) \sin^4 \theta + \sin^2 \theta \cos^2 \theta = \sin^2 \theta (\sin^2 \theta + \cos^2 \theta) = \sin^2 \theta$$

$$(i) \sin^4 \theta + 2 \sin^2 \theta \cos^2 \theta + \cos^4 \theta = (\sin^2 \theta + \cos^2 \theta)^2 = 1^2 = 1$$

© Pearson Education Ltd 2008

Solutionbank C2

Edexcel Modular Mathematics for AS and A-Level

Trigonometrical identities and simple equations

Exercise A, Question 2

Question:

Given that $2 \sin \theta = 3 \cos \theta$, find the value of $\tan \theta$.

Solution:

Given $2 \sin \theta = 3 \cos \theta$

So $\frac{\sin \theta}{\cos \theta} = \frac{3}{2}$ (divide both sides by $2 \cos \theta$)

So $\tan \theta = \frac{3}{2}$

© Pearson Education Ltd 2008

Solutionbank C2

Edexcel Modular Mathematics for AS and A-Level

Trigonometrical identities and simple equations

Exercise A, Question 3

Question:

Given that $\sin x \cos y = 3 \cos x \sin y$, express $\tan x$ in terms of $\tan y$.

Solution:

As $\sin x \cos y = 3 \cos x \sin y$

$$\text{So } \frac{\sin x \cos y}{\cos x \cos y} = 3 \frac{\cos x \sin y}{\cos x \cos y}$$

So $\tan x = 3 \tan y$

© Pearson Education Ltd 2008

Solutionbank C2

Edexcel Modular Mathematics for AS and A-Level

Trigonometrical identities and simple equations

Exercise A, Question 4

Question:

Express in terms of $\sin \theta$ only:

(a) $\cos^2 \theta$

(b) $\tan^2 \theta$

(c) $\cos \theta \tan \theta$

(d) $\frac{\cos \theta}{\tan \theta}$

(e) $(\cos \theta - \sin \theta)(\cos \theta + \sin \theta)$

Solution:

(a) As $\sin^2 \theta + \cos^2 \theta \equiv 1$

So $\cos^2 \theta \equiv 1 - \sin^2 \theta$

(b) $\tan^2 \theta \equiv \frac{\sin^2 \theta}{\cos^2 \theta} \equiv \frac{\sin^2 \theta}{1 - \sin^2 \theta}$

(c) $\cos \theta \tan \theta$

$$= \cancel{\cos \theta} \times \frac{\sin \theta}{\cancel{\cos \theta}}$$

$$= \sin \theta$$

(d) $\frac{\cos \theta}{\tan \theta} = \frac{\cos \theta}{\frac{\sin \theta}{\cos \theta}} = \cos \theta \times \frac{\cos \theta}{\sin \theta} = \frac{\cos^2 \theta}{\sin \theta}$

So $\frac{\cos \theta}{\tan \theta} = \frac{1 - \sin^2 \theta}{\sin \theta}$ or $\frac{1}{\sin \theta} - \sin \theta$

(e) $(\cos \theta - \sin \theta)(\cos \theta + \sin \theta) = \cos^2 \theta - \sin^2 \theta = (1 - \sin^2 \theta) - \sin^2 \theta = 1 - 2\sin^2 \theta$

Solutionbank C2

Edexcel Modular Mathematics for AS and A-Level

Trigonometrical identities and simple equations

Exercise A, Question 5

Question:

Using the identities $\sin^2 A + \cos^2 A \equiv 1$ and/or $\tan A \equiv \frac{\sin A}{\cos A}$ $\left(\cos A \neq 0 \right)$, prove that:

(a) $(\sin \theta + \cos \theta)^2 \equiv 1 + 2 \sin \theta \cos \theta$

(b) $\frac{1}{\cos \theta} - \cos \theta \equiv \sin \theta \tan \theta$

(c) $\tan x + \frac{1}{\tan x} \equiv \frac{1}{\sin x \cos x}$

(d) $\cos^2 A - \sin^2 A \equiv 2 \cos^2 A - 1 \equiv 1 - 2 \sin^2 A$

(e) $(2 \sin \theta - \cos \theta)^2 + (\sin \theta + 2 \cos \theta)^2 \equiv 5$

(f) $2 - (\sin \theta - \cos \theta)^2 \equiv (\sin \theta + \cos \theta)^2$

(g) $\sin^2 x \cos^2 y - \cos^2 x \sin^2 y = \sin^2 x - \sin^2 y$

Solution:

(a) LHS = $(\sin \theta + \cos \theta)^2$
 $= \sin^2 \theta + 2 \sin \theta \cos \theta + \cos^2 \theta$
 $= (\sin^2 \theta + \cos^2 \theta) + 2 \sin \theta \cos \theta$
 $= 1 + 2 \sin \theta \cos \theta$
 = RHS

(b) LHS = $\frac{1}{\cos \theta} - \cos \theta$
 $= \frac{1 - \cos^2 \theta}{\cos \theta}$
 $= \frac{\sin^2 \theta}{\cos \theta}$
 $= \sin \theta \times \frac{\sin \theta}{\cos \theta}$
 $= \sin \theta \tan \theta$
 = RHS

(c) LHS = $\tan x^\circ + \frac{1}{\tan x^\circ}$
 $= \frac{\sin x^\circ}{\cos x^\circ} + \frac{\cos x^\circ}{\sin x^\circ}$
 $= \frac{\sin^2 x^\circ + \cos^2 x^\circ}{\sin x^\circ \cos x^\circ}$

$$= \frac{1}{\sin x^\circ \cos x^\circ}$$

$$= \text{RHS}$$

$$\begin{aligned} \text{(d) LHS} &= \cos^2 A - \sin^2 A \\ &\equiv \cos^2 A - (1 - \cos^2 A) \\ &\equiv \cos^2 A - 1 + \cos^2 A \\ &\equiv 2 \cos^2 A - 1 \checkmark \\ &\equiv 2(1 - \sin^2 A) - 1 \\ &\equiv 2 - 2 \sin^2 A - 1 \\ &\equiv 1 - 2 \sin^2 A \checkmark \end{aligned}$$

$$\begin{aligned} \text{(e) LHS} &= (2 \sin \theta - \cos \theta)^2 + (\sin \theta + 2 \cos \theta)^2 \\ &\equiv 4 \sin^2 \theta - 4 \sin \theta \cos \theta + \cos^2 \theta + \sin^2 \theta + 4 \sin \theta \cos \theta + 4 \cos^2 \theta \\ &\equiv 5 \sin^2 \theta + 5 \cos^2 \theta \\ &\equiv 5(\sin^2 \theta + \cos^2 \theta) \\ &\equiv 5 \\ &\equiv \text{RHS} \end{aligned}$$

$$\begin{aligned} \text{(f) LHS} &\equiv 2 - (\sin \theta - \cos \theta)^2 \\ &= 2 - (\sin^2 \theta - 2 \sin \theta \cos \theta + \cos^2 \theta) \\ &= 2 - (1 - 2 \sin \theta \cos \theta) \\ &= 1 + 2 \sin \theta \cos \theta \\ &= \sin^2 \theta + \cos^2 \theta + 2 \sin \theta \cos \theta \\ &= (\sin \theta + \cos \theta)^2 \\ &= \text{RHS} \end{aligned}$$

$$\begin{aligned} \text{(g) LHS} &= \sin^2 x \cos^2 y - \cos^2 x \sin^2 y \\ &= \sin^2 x (1 - \sin^2 y) - (1 - \sin^2 x) \sin^2 y \\ &= \sin^2 x - \sin^2 x \sin^2 y - \sin^2 y + \sin^2 x \sin^2 y \\ &= \sin^2 x - \sin^2 y \\ &= \text{RHS} \end{aligned}$$

Solutionbank C2

Edexcel Modular Mathematics for AS and A-Level

Trigonometrical identities and simple equations

Exercise A, Question 6

Question:

Find, without using your calculator, the values of:

(a) $\sin \theta$ and $\cos \theta$, given that $\tan \theta = \frac{5}{12}$ and θ is acute.

(b) $\sin \theta$ and $\tan \theta$, given that $\cos \theta = -\frac{3}{5}$ and θ is obtuse.

(c) $\cos \theta$ and $\tan \theta$, given that $\sin \theta = -\frac{7}{25}$ and $270^\circ < \theta < 360^\circ$.

Solution:

(a)

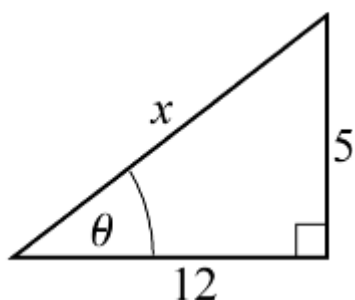

Using Pythagoras' Theorem,

$$x^2 = 12^2 + 5^2 = 169$$

$$x = 13$$

$$\text{So } \sin \theta = \frac{5}{13} \text{ and } \cos \theta = \frac{12}{13}$$

(b)

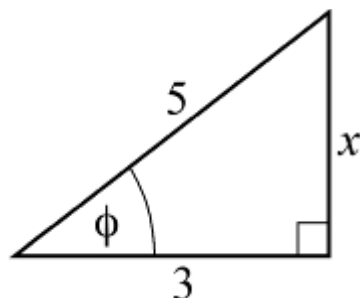

Using Pythagoras' Theorem, $x = 4$.

$$\text{So } \sin \phi = \frac{4}{5} \text{ and } \tan \phi = \frac{4}{3}$$

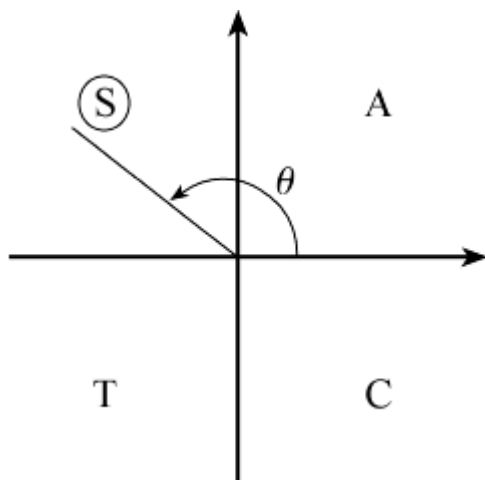

As θ is obtuse,

$$\sin \theta = \sin \phi = \frac{4}{5}$$

and

$$\tan \theta = -\tan \phi = -\frac{4}{3}$$

(c)

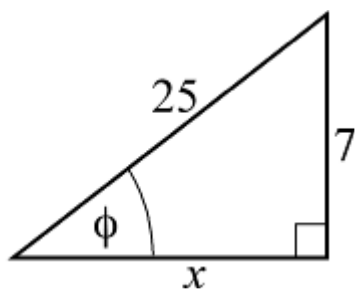

Using Pythagoras' Theorem,

$$x^2 + 7^2 = 25^2$$

$$x^2 = 25^2 - 7^2 = 576$$

$$x = 24$$

$$\text{So } \cos \phi = \frac{24}{25} \text{ and } \tan \phi = \frac{7}{24}$$

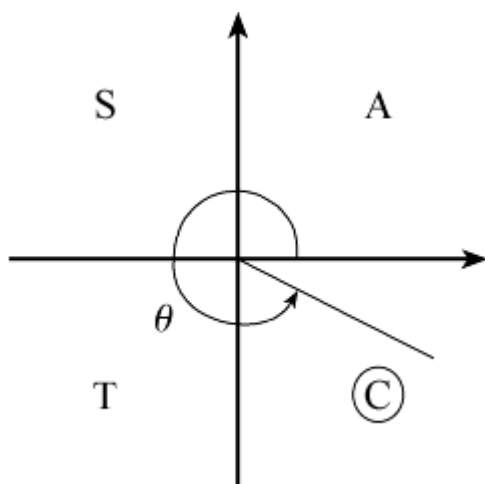

As θ is in the 4th quadrant,

$$\cos \theta = +\cos \phi = +\frac{24}{25}$$

and

$$\tan \theta = -\tan \phi = -\frac{7}{24}$$

© Pearson Education Ltd 2008

Solutionbank C2

Edexcel Modular Mathematics for AS and A-Level

Trigonometrical identities and simple equations

Exercise A, Question 7

Question:

Given that $\sin \theta = \frac{2}{3}$ and that θ is obtuse, find the exact value of: (a) $\cos \theta$, (b) $\tan \theta$.

Solution:

Consider the angle ϕ where $\sin \phi = \frac{2}{3}$.

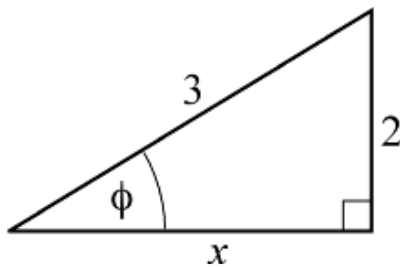

Using Pythagoras' Theorem, $x = \sqrt{5}$

(a) So $\cos \phi = \frac{\sqrt{5}}{3}$

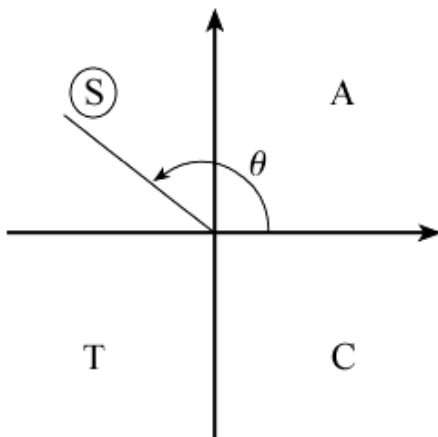

As θ is obtuse, $\cos \theta = -\cos \phi = -\frac{\sqrt{5}}{3}$

(b) From the triangle,

$$\tan \phi = \frac{2}{\sqrt{5}} = \frac{2\sqrt{5}}{5}$$

Using the quadrant diagram,

$$\tan \theta = -\tan \phi = -\frac{2\sqrt{5}}{5}$$

Solutionbank C2

Edexcel Modular Mathematics for AS and A-Level

Trigonometrical identities and simple equations

Exercise A, Question 8

Question:

Given that $\tan \theta = -\sqrt{3}$ and that θ is reflex, find the exact value of: (a) $\sin \theta$, (b) $\cos \theta$.

Solution:

Draw a right-angled triangle with $\tan \phi = +\sqrt{3} = \frac{\sqrt{3}}{1}$

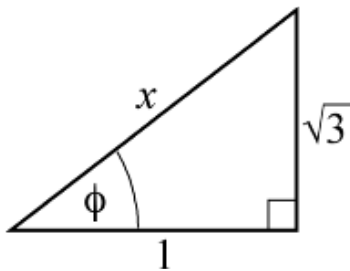

Using Pythagoras' Theorem,

$$x^2 = (\sqrt{3})^2 + 1^2 = 4$$

So $x = 2$

$$(a) \sin \phi = \frac{\sqrt{3}}{2}$$

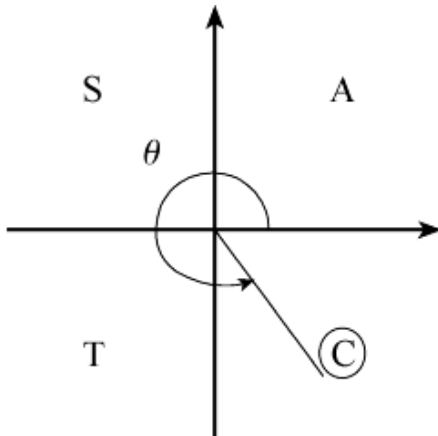

As θ is reflex and $\tan \theta$ is $-ve$, θ is in the 4th quadrant.

$$\text{So } \sin \theta = -\sin \phi = \frac{-\sqrt{3}}{2}$$

$$(b) \cos \phi = \frac{1}{2}$$

$$\text{As } \cos \theta = \cos \phi, \cos \theta = \frac{1}{2}$$

Solutionbank C2

Edexcel Modular Mathematics for AS and A-Level

Trigonometrical identities and simple equations

Exercise A, Question 9

Question:

Given that $\cos \theta = \frac{3}{4}$ and that θ is reflex, find the exact value of: (a) $\sin \theta$, (b) $\tan \theta$.

Solution:

Draw a right-angled triangle with $\cos \phi = \frac{3}{4}$

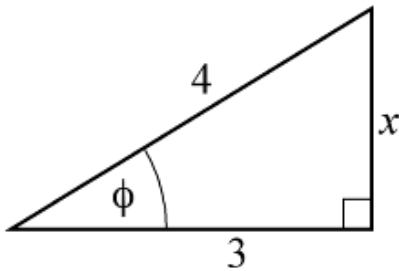

Using Pythagoras' Theorem,

$$x^2 + 3^2 = 4^2$$

$$x^2 = 4^2 - 3^2 = 7$$

$$x = \sqrt{7}$$

$$\text{So } \sin \phi = \frac{\sqrt{7}}{4} \text{ and } \tan \phi = \frac{\sqrt{7}}{3}$$

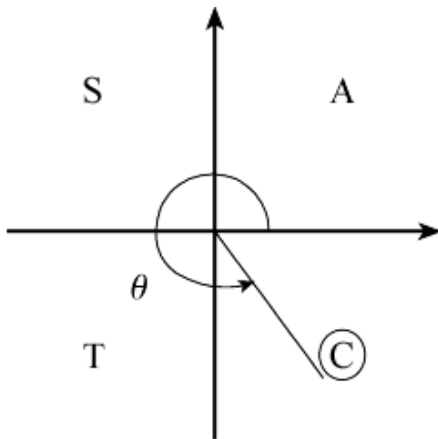

As θ is reflex and $\cos \theta$ is +ve, θ is in the 4th quadrant.

$$\text{(a) } \sin \theta = -\sin \phi = -\frac{\sqrt{7}}{4}$$

$$\text{(b) } \tan \theta = -\tan \phi = -\frac{\sqrt{7}}{3}$$

Solutionbank C2

Edexcel Modular Mathematics for AS and A-Level

Trigonometrical identities and simple equations

Exercise A, Question 10

Question:

In each of the following, eliminate θ to give an equation relating x and y :

(a) $x = \sin \theta, y = \cos \theta$

(b) $x = \sin \theta, y = 2 \cos \theta$

(c) $x = \sin \theta, y = \cos^2 \theta$

(d) $x = \sin \theta, y = \tan \theta$

(e) $x = \sin \theta + \cos \theta, y = \cos \theta - \sin \theta$

Solution:

(a) As $\sin^2 \theta + \cos^2 \theta \equiv 1$
 $x^2 + y^2 = 1$

(b) $\sin \theta = x$ and $\cos \theta = \frac{y}{2}$

So, using $\sin^2 \theta + \cos^2 \theta \equiv 1$

$$x^2 + \left(\frac{y}{2}\right)^2 = 1 \text{ or } x^2 + \frac{y^2}{4} = 1 \text{ or } 4x^2 + y^2 = 4$$

(c) As $\sin \theta = x, \sin^2 \theta = x^2$

Using $\sin^2 \theta + \cos^2 \theta \equiv 1$

$$x^2 + y = 1$$

(d) As $\tan \theta = \frac{\sin \theta}{\cos \theta}$

$$\cos \theta = \frac{\sin \theta}{\tan \theta}$$

So $\cos \theta = \frac{x}{y}$

Using $\sin^2 \theta + \cos^2 \theta \equiv 1$

$$x^2 + \frac{x^2}{y^2} = 1 \text{ or } x^2 y^2 + x^2 = y^2$$

(e) $\sin \theta + \cos \theta = x$

$-\sin \theta + \cos \theta = y$

Adding up the two equations: $2 \cos \theta = x + y$

So $\cos \theta = \frac{x+y}{2}$

Subtracting the two equations: $2 \sin \theta = x - y$

So $\sin \theta = \frac{x-y}{2}$

Using $\sin^2 \theta + \cos^2 \theta \equiv 1$

$$\left(\frac{x-y}{2}\right)^2 + \left(\frac{x+y}{2}\right)^2 = 1$$

$$x^2 - 2xy + y^2 + x^2 + 2xy + y^2 = 4$$

$$2x^2 + 2y^2 = 4$$

$$x^2 + y^2 = 2$$

© Pearson Education Ltd 2008

Solutionbank C2

Edexcel Modular Mathematics for AS and A-Level

Trigonometrical identities and simple equations

Exercise B, Question 1

Question:

Solve the following equations for θ , in the interval $0 < \theta \leq 360^\circ$:

(a) $\sin \theta = -1$

(b) $\tan \theta = \sqrt{3}$

(c) $\cos \theta = \frac{1}{2}$

(d) $\sin \theta = \sin 15^\circ$

(e) $\cos \theta = -\cos 40^\circ$

(f) $\tan \theta = -1$

(g) $\cos \theta = 0$

(h) $\sin \theta = -0.766$

(i) $7 \sin \theta = 5$

(j) $2 \cos \theta = -\sqrt{2}$

(k) $\sqrt{3} \sin \theta = \cos \theta$

(l) $\sin \theta + \cos \theta = 0$

(m) $3 \cos \theta = -2$

(n) $(\sin \theta - 1)(5 \cos \theta + 3) = 0$

(o) $\tan \theta = \tan \theta (2 + 3 \sin \theta)$

Solution:

(a) Using the graph of $y = \sin \theta$
 $\sin \theta = -1$ when $\theta = 270^\circ$

(b) $\tan \theta = \sqrt{3}$

The calculator solution is 60° ($\tan^{-1} \sqrt{3}$) and, as $\tan \theta$ is +ve, θ lies in the 1st and 3rd quadrants.
 $\theta = 60^\circ$ and $(180^\circ + 60^\circ) = 60^\circ, 240^\circ$

(c) $\cos \theta = \frac{1}{2}$

Calculator solution is 60° and as $\cos \theta$ is +ve, θ lies in the 1st and 4th quadrants.
 $\theta = 60^\circ$ and $(360^\circ - 60^\circ) = 60^\circ, 300^\circ$

(d) $\sin \theta = \sin 15^\circ$

The acute angle satisfying the equation is $\theta = 15^\circ$.
 As $\sin \theta$ is +ve, θ lies in the 1st and 2nd quadrants, so

$$\theta = 15^\circ \text{ and } (180^\circ - 15^\circ) = 165^\circ$$

(e) A first solution is $\cos^{-1}(-\cos 40^\circ) = 140^\circ$
 A second solution of $\cos \theta = k$ is $360^\circ - 140^\circ$.
 So second solution is 220°
 (Use the quadrant diagram as a check.)

(f) A first solution is $\tan^{-1}(-1) = -45^\circ$
 Use the quadrant diagram, noting that as \tan is $-ve$, solutions are in the 2nd and 4th quadrants.
 (-45° is not in the given interval)
 So solutions are 135° and 315° .

(g) From the graph of $y = \cos \theta$
 $\cos \theta = 0$ when $\theta = 90^\circ, 270^\circ$

(h) The calculator solution is -50.0° (3 s.f.)
 As $\sin \theta$ is $-ve$, θ lies in the 3rd and 4th quadrants.

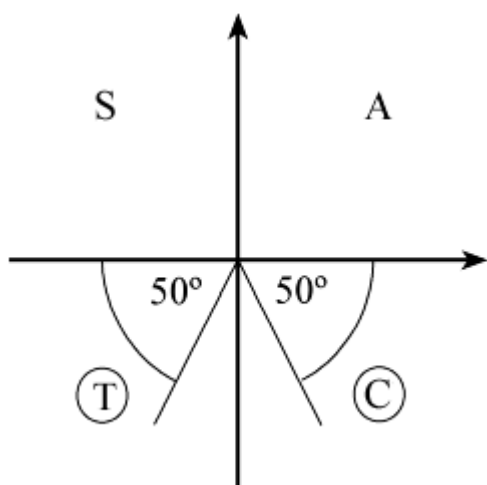

Solutions are 230° and 310° .

[These are $180^\circ + \alpha$ and $360^\circ - \alpha$ where $\alpha = \cos^{-1}(-0.766)$]

(i) $\sin \theta = \frac{5}{7}$

First solution is $\sin^{-1}\left(\frac{5}{7}\right) = 45.6^\circ$

Second solution is $180^\circ - 45.6^\circ = 134.4^\circ$

(j) $\cos \theta = -\frac{\sqrt{2}}{2}$

Calculator solution is 135°

As $\cos \theta$ is $-ve$, θ is in the 2nd and 3rd quadrants.

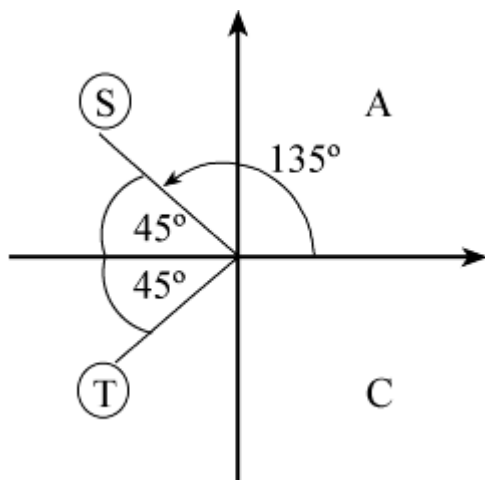

Solutions are 135° and 225° (135° and $360^\circ - 135^\circ$)

(k) $\sqrt{3} \sin \theta = \cos \theta$

So $\tan \theta = \frac{1}{\sqrt{3}}$ dividing both sides by $\sqrt{3} \cos \theta$

Calculator solution is 30°

As $\tan \theta$ is +ve, θ is in the 1st and 3rd quadrants.

Solutions are 30° , 210° (30° and $180^\circ + 30^\circ$)

(l) $\sin \theta + \cos \theta = 0$

So $\sin \theta = -\cos \theta \Rightarrow \tan \theta = -1$

Calculator solution (-45°) is not in given interval

As $\tan \theta$ is -ve, θ is in the 2nd and 4th quadrants.

Solutions are 135° and 315° [$180^\circ + \tan^{-1}(-1)$, $360^\circ + \tan^{-1}(-1)$]

(m) Calculator solution is $\cos^{-1}\left(-\frac{2}{3}\right) = 131.8^\circ$ (1 d.p.)

Second solution is $360^\circ - 131.8^\circ = 228.2^\circ$

(n) As $(\sin \theta - 1)(5 \cos \theta + 3) = 0$

either $\sin \theta - 1 = 0$ or $5 \cos \theta + 3 = 0$

So $\sin \theta = 1$ or $\cos \theta = -\frac{3}{5}$

Use the graph of $y = \sin \theta$ to read off solutions of $\sin \theta = 1$

$\sin \theta = 1 \Rightarrow \theta = 90^\circ$

For $\cos \theta = -\frac{3}{5}$,

calculator solution is $\cos^{-1}\left(-\frac{3}{5}\right) = 126.9^\circ$

second solution is $360^\circ - 126.9^\circ = 233.1^\circ$

Solutions are 90° , 126.9° , 233.1°

(o) Rearrange as

$\tan \theta (2 + 3 \sin \theta) - \tan \theta = 0$

$\tan \theta [(2 + 3 \sin \theta) - 1] = 0$ factorising

$\tan \theta (3 \sin \theta + 1) = 0$

So $\tan \theta = 0$ or $\sin \theta = -\frac{1}{3}$

From graph of $y = \tan \theta$, $\tan \theta = 0 \Rightarrow \theta = 180^\circ, 360^\circ$ (0° not in given interval)

For $\sin \theta = -\frac{1}{3}$, calculator solution (-19.5°) is not in interval.

Solutions are $180^\circ - \sin^{-1}\left(-\frac{1}{3}\right)$ and $360^\circ + \sin^{-1}\left(-\frac{1}{3}\right)$ or use quadrant diagram.

Complete set of solutions $180^\circ, 199.5^\circ, 340.5^\circ, 360^\circ$

© Pearson Education Ltd 2008

Solutionbank C2

Edexcel Modular Mathematics for AS and A-Level

Trigonometrical identities and simple equations

Exercise B, Question 2

Question:

Solve the following equations for x , giving your answers to 3 significant figures where appropriate, in the intervals indicated:

(a) $\sin x^\circ = -\frac{\sqrt{3}}{2}, -180 \leq x \leq 540$

(b) $2 \sin x^\circ = -0.3, -180 \leq x \leq 180$

(c) $\cos x^\circ = -0.809, -180 \leq x \leq 180$

(d) $\cos x^\circ = 0.84, -360 < x < 0$

(e) $\tan x^\circ = -\frac{\sqrt{3}}{3}, 0 \leq x \leq 720$

(f) $\tan x^\circ = 2.90, 80 \leq x \leq 440$

Solution:

(a) Calculator solution of $\sin x^\circ = -\frac{\sqrt{3}}{2}$ is $x = -60$

As $\sin x^\circ$ is $-ve$, x is in the 3rd and 4th quadrants.

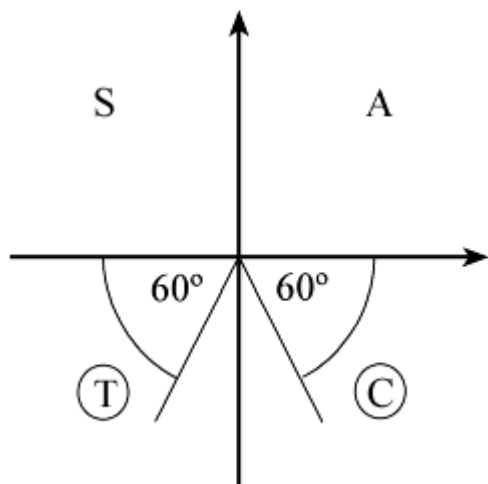

Read off all solutions in the interval $-180 \leq x \leq 540$
 $x = -120, -60, 240, 300$

(b) $2 \sin x^\circ = -0.3$

$\sin x^\circ = -0.15$

First solution is $x = \sin^{-1}(-0.15) = -8.63$ (3 s.f.)

As $\sin x^\circ$ is $-ve$, x is in the 3rd and 4th quadrants.

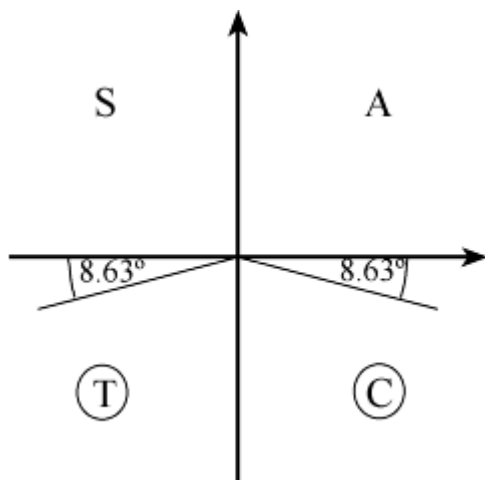

Read off all solutions in the interval $-180 \leq x \leq 180$
 $x = -171.37, -8.63 = -171, -8.63$ (3 s.f.)

(c) $\cos x^\circ = -0.809$

Calculator solution is 144 (3 s.f.)

As $\cos x^\circ$ is -ve, x is in the 2nd and 3rd quadrants.

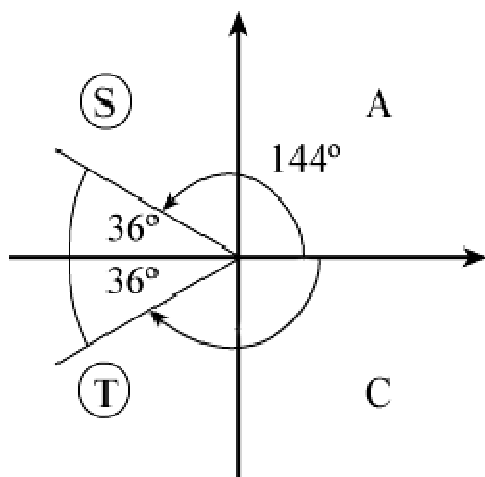

Read off all solutions in the interval $-180 \leq x \leq 180$

$x = -144, +144$

[Note: Here solutions are $\cos^{-1}(-0.809)$ and $\{360 - \cos^{-1}(-0.809)\} \{-360\}$

(d) $\cos x^\circ = 0.84$

Calculator solution is 32.9 (3 s.f.) (not in interval)

As $\cos x^\circ$ is +ve, x is in the 1st and 4th quadrants.

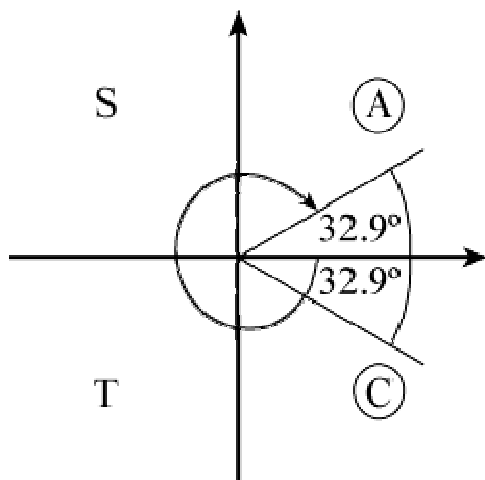

Read off all solutions in the interval $-360 < x < 0$

$$x = -327, -32.9 \text{ (3 s.f.)}$$

[Note: Here solutions are $\cos^{-1}(0.84) - 360$ and $\{360 - \cos^{-1}(0.84)\} - 360$]

$$(e) \tan x^\circ = -\frac{\sqrt{3}}{3}$$

$$\text{Calculator solution is } \tan^{-1}\left(-\frac{\sqrt{3}}{3}\right) = -30 \text{ (not in interval)}$$

As $\tan x^\circ$ is $-ve$, x is in the 2nd and 4th quadrants.

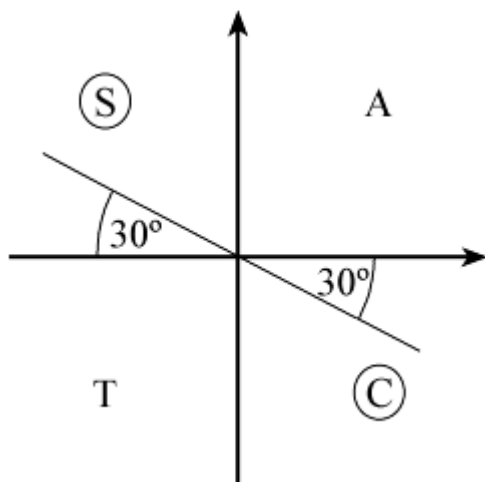

Read off all solutions in the interval $0 \leq x \leq 720$

$$x = 150, 330, 510, 690$$

[Note: Here solutions are $\tan^{-1}\left(-\frac{\sqrt{3}}{3}\right) + 180$, $\tan^{-1}\left(-\frac{\sqrt{3}}{3}\right) + 360$, $\tan^{-1}\left(-\frac{\sqrt{3}}{3}\right)$

$$+ 540, \tan^{-1}\left(-\frac{\sqrt{3}}{3}\right) + 720]$$

$$(f) \tan x^\circ = 2.90$$

Calculator solution is $\tan^{-1}(2.90) = 71.0 \text{ (3 s.f.)}$ (not in interval)

As $\tan x^\circ$ is $+ve$, x is in the 1st and 3rd quadrants.

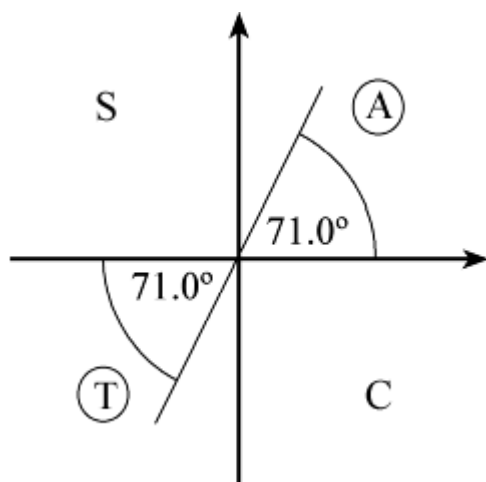

Read off all solutions in the interval $80 \leq x \leq 440$

$x = 251, 431$

[Note: Here solutions are $\tan^{-1}(2.90) + 180, \tan^{-1}(2.90) + 360$]

© Pearson Education Ltd 2008

Solutionbank C2

Edexcel Modular Mathematics for AS and A-Level

Trigonometrical identities and simple equations

Exercise B, Question 3

Question:

Solve, in the intervals indicated, the following equations for θ , where θ is measured in radians. Give your answer in terms of π or 2 decimal places.

(a) $\sin \theta = 0, -2\pi < \theta \leq 2\pi$

(b) $\cos \theta = -\frac{1}{2}, -2\pi < \theta \leq \pi$

(c) $\sin \theta = \frac{1}{\sqrt{2}}, -2\pi < \theta \leq \pi$

(d) $\sin \theta = \tan \theta, 0 < \theta \leq 2\pi$

(e) $2(1 + \tan \theta) = 1 - 5 \tan \theta, -\pi < \theta \leq 2\pi$

(f) $2 \cos \theta = 3 \sin \theta, 0 < \theta \leq 2\pi$

Solution:

(a) Use your graph of $y = \sin \theta$ to read off values of θ for which $\sin \theta = 0$.
In the interval $-2\pi < \theta \leq 2\pi$, solutions are $-\pi, 0, \pi, 2\pi$.

(b) Calculator solution of $\cos \theta = -\frac{1}{2}$ is $\cos^{-1} \left(-\frac{1}{2} \right) = 2.09$ radians

[You should know that $\cos^{-1} \left(-\frac{1}{2} \right) = \frac{2\pi}{3}$]

As $\cos \theta$ is $-ve$, θ is in 2nd and 3rd quadrants.

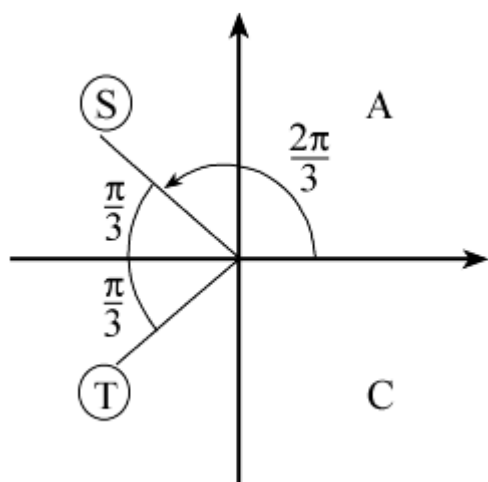

Read off all solutions in the interval $-2\pi < \theta \leq \pi$

$$\theta = -\frac{4\pi}{3}, -\frac{2\pi}{3}, \frac{2\pi}{3} \quad (-4.19, -2.09, +2.09)$$

(c) Calculator solution of $\sin \theta = \frac{1}{\sqrt{2}}$ is $\sin^{-1} \left(\frac{1}{\sqrt{2}} \right) = 0.79$ radians or $\frac{\pi}{4}$

As $\sin \theta$ is +ve, θ is in the 1st and 2nd quadrants.

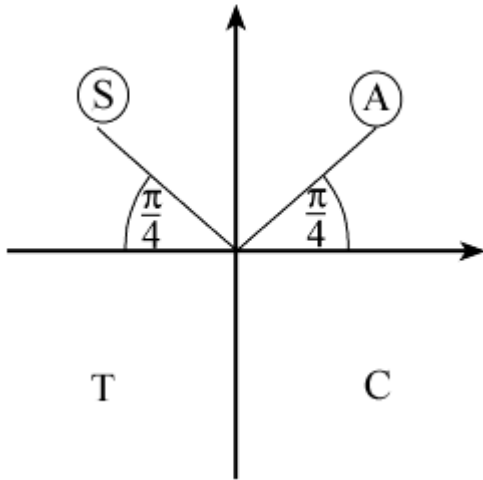

Read off all solutions in the interval $-2\pi < \theta \leq \pi$

$$\theta = -\frac{7\pi}{4}, -\frac{5\pi}{4}, \frac{\pi}{4}, \frac{3\pi}{4}$$

(d) $\sin \theta = \tan \theta$

$$\sin \theta = \frac{\sin \theta}{\cos \theta}$$

(multiply through by $\cos \theta$)

$$\sin \theta \cos \theta = \sin \theta$$

$$\sin \theta \cos \theta - \sin \theta = 0$$

$$\sin \theta (\cos \theta - 1) = 0$$

So $\sin \theta = 0$ or $\cos \theta = 1$ for $0 < \theta \leq 2\pi$

From the graph if $y = \sin \theta$, $\sin \theta = 0$ where $\theta = \pi, 2\pi$

From the graph of $y = \cos \theta$, $\cos \theta = 1$ where $\theta = 2\pi$

So solutions are $\pi, 2\pi$

(e) $2(1 + \tan \theta) = 1 - 5 \tan \theta$

$$\Rightarrow 2 + 2 \tan \theta = 1 - 5 \tan \theta$$

$$\Rightarrow 7 \tan \theta = -1$$

$$\Rightarrow \tan \theta = -\frac{1}{7}$$

Calculator solution is $\theta = \tan^{-1} \left(-\frac{1}{7} \right) = -0.14$ radians (2 d.p.)

As $\tan \theta$ is -ve, θ is in the 2nd and 4th quadrants.

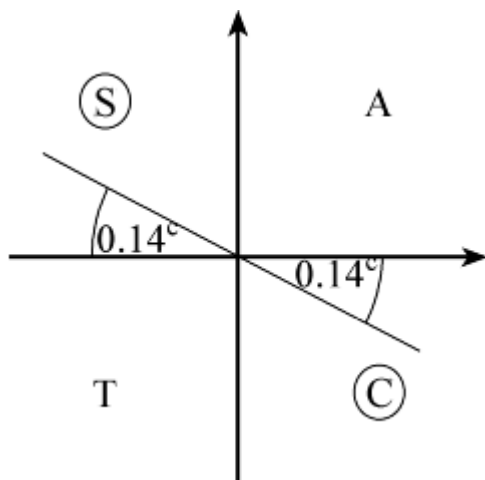

Read off all solutions in the interval $-\pi < \theta \leq 2\pi$

$$\theta = -0.14, 3.00, 6.14 \left[\tan^{-1} \left(-\frac{1}{7} \right), \tan^{-1} \left(-\frac{1}{7} \right) + \pi, \tan^{-1} \left(-\frac{1}{7} \right) + 2\pi \right]$$

(f) As $2 \cos \theta = 3 \sin \theta$

$$\frac{2 \cos \theta}{3 \cos \theta} = \frac{3 \sin \theta}{3 \cos \theta}$$

$$\text{So } \tan \theta = \frac{2}{3}$$

Calculator solution is $\theta = \tan^{-1} \left(\frac{2}{3} \right) = 0.59$ radians (2 d.p.)

As $\tan \theta$ is +ve, θ is in the 1st and 3rd quadrants.

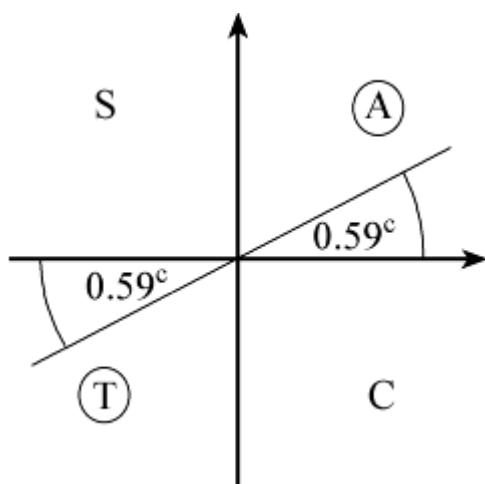

Read off all solutions in the interval $0 < \theta \leq 2\pi$

$$\theta = 0.59, 3.73 \left[\tan^{-1} \left(\frac{2}{3} \right), \tan^{-1} \left(\frac{2}{3} \right) + \pi \right]$$

Solutionbank C2

Edexcel Modular Mathematics for AS and A-Level

Trigonometrical identities and simple equations

Exercise C, Question 1

Question:

Find the values of θ , in the interval $0 \leq \theta \leq 360^\circ$, for which:

(a) $\sin 4\theta = 0$

(b) $\cos 3\theta = -1$

(c) $\tan 2\theta = 1$

(d) $\cos 2\theta = \frac{1}{2}$

(e) $\tan \frac{1}{2}\theta = -\frac{1}{\sqrt{3}}$

(f) $\sin \left(-\theta \right) = \frac{1}{\sqrt{2}}$

(g) $\tan (45^\circ - \theta) = -1$

(h) $2 \sin (\theta - 20^\circ) = 1$

(i) $\tan (\theta + 75^\circ) = \sqrt{3}$

(j) $\cos (50^\circ + 2\theta) = -1$

Solution:

(a) $\sin 4\theta = 0 \quad 0 \leq \theta \leq 360^\circ$

Let $X = 4\theta$ so $0 \leq X \leq 1440^\circ$

Solve $\sin X = 0$ in the interval $0 \leq X \leq 1440^\circ$

From the graph of $y = \sin X$, $\sin X = 0$ where

$X = 0, 180^\circ, 360^\circ, 540^\circ, 720^\circ, 900^\circ, 1080^\circ, 1260^\circ, 1440^\circ$

$\theta = \frac{X}{4} = 0, 45^\circ, 90^\circ, 135^\circ, 180^\circ, 225^\circ, 270^\circ, 315^\circ, 360^\circ$

(b) $\cos 3\theta = -1 \quad 0 \leq \theta \leq 360^\circ$

Let $X = 3\theta$ so $0 \leq X \leq 1080^\circ$

Solve $\cos X = -1$ in the interval $0 \leq X \leq 1080^\circ$

From the graph of $y = \cos X$, $\cos X = -1$ where

$X = 180^\circ, 540^\circ, 900^\circ$

$\theta = \frac{X}{3} = 60^\circ, 180^\circ, 300^\circ$

(c) $\tan 2\theta = 1 \quad 0 \leq \theta \leq 360^\circ$

Let $X = 2\theta$

Solve $\tan X = 1$ in the interval $0 \leq X \leq 720^\circ$

A solution is $X = \tan^{-1} 1 = 45^\circ$

As $\tan X$ is +ve, X is in the 1st and 3rd quadrants.

So $X = 45^\circ, 225^\circ, 405^\circ, 585^\circ$

$$\theta = \frac{X}{2} = 22 \frac{1}{2}^\circ, 112 \frac{1}{2}^\circ, 202 \frac{1}{2}^\circ, 292 \frac{1}{2}^\circ$$

$$(d) \cos 2\theta = \frac{1}{2} \quad 0 \leq \theta \leq 360^\circ$$

Let $X = 2\theta$

$$\text{Solve } \cos X = \frac{1}{2} \text{ in the interval } 0 \leq X \leq 720^\circ$$

$$\text{A solution is } X = \cos^{-1} \left(\frac{1}{2} \right) = 60^\circ$$

As $\cos X$ is +ve, X is in the 1st and 4th quadrants.

So $X = 60^\circ, 300^\circ, 420^\circ, 660^\circ$

$$\theta = \frac{X}{2} = 30^\circ, 150^\circ, 210^\circ, 330^\circ$$

$$(e) \tan \frac{1}{2}\theta = -\frac{1}{\sqrt{3}} \quad 0 \leq \theta \leq 360^\circ$$

Let $X = \frac{1}{2}\theta$

$$\text{Solve } \tan X = -\frac{1}{\sqrt{3}} \text{ in the interval } 0 \leq X \leq 180^\circ$$

$$\text{A solution is } X = \tan^{-1} \left(-\frac{1}{\sqrt{3}} \right) = -30^\circ \text{ (not in interval)}$$

As $\tan X$ is -ve, X is in the 2nd and 4th quadrants.

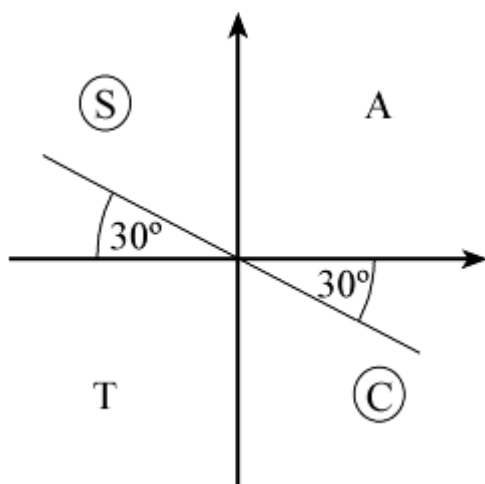

Read off solutions in the interval $0 \leq X \leq 180^\circ$

$$X = 150^\circ$$

$$\text{So } \theta = 2X = 300^\circ$$

$$(f) \sin \left(-\theta \right) = \frac{1}{\sqrt{2}} \quad 0 \leq \theta \leq 360^\circ$$

Let $X = -\theta$

$$\text{Solve } \sin X = \frac{1}{\sqrt{2}} \text{ in the interval } 0 \geq X \geq -360^\circ$$

$$\text{A solution is } X = \sin^{-1} \left(\frac{1}{\sqrt{2}} \right) = 45^\circ$$

As $\sin X$ is +ve, X is in the 1st and 2nd quadrants.

$$X = -315^\circ, -225^\circ$$

So $\theta = -X = 225^\circ, 315^\circ$

(g) $\tan(45^\circ - \theta) = -1$ $0 \leq \theta \leq 360^\circ$

Let $X = 45^\circ - \theta$ so $0 \geq -\theta \geq -360^\circ$

Solve $\tan X = -1$ in the interval $45^\circ \geq X \geq -315^\circ$

A solution is $X = \tan^{-1}(-1) = -45^\circ$

As $\tan X$ is -ve, X is in the 2nd and 4th quadrants.

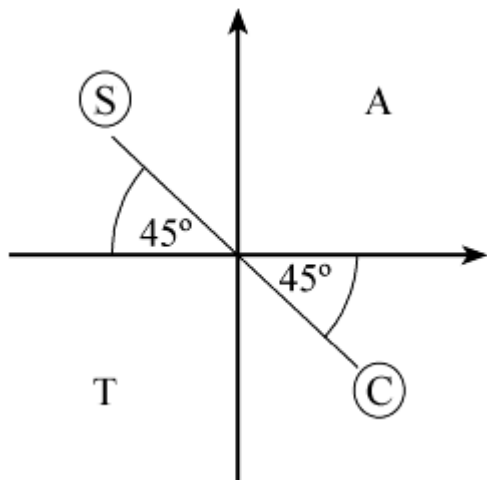

$X = -225^\circ, -45^\circ$

So $\theta = 45^\circ - X = 90^\circ, 270^\circ$

(h) $2 \sin(\theta - 20^\circ) = 1$ so $\sin(\theta - 20^\circ) = \frac{1}{2}$ $0 \leq \theta \leq 360^\circ$

Let $X = \theta - 20^\circ$

Solve $\sin X = \frac{1}{2}$ in the interval $-20^\circ \leq X \leq 340^\circ$

A solution is $X = \sin^{-1}\left(\frac{1}{2}\right) = 30^\circ$

As $\sin X$ is +ve, solutions are in the 1st and 2nd quadrants.

$X = 30^\circ, 150^\circ$

So $\theta = X + 20^\circ = 50^\circ, 170^\circ$

(i) Solve $\tan X = \sqrt{3}$ where $X = (\theta + 75^\circ)$

Interval for X is $75^\circ \leq X \leq 435^\circ$

One solution is $\tan^{-1}(\sqrt{3}) = 60^\circ$ (not in the interval)

As $\tan X$ is +ve, X is in the 1st and 3rd quadrants.

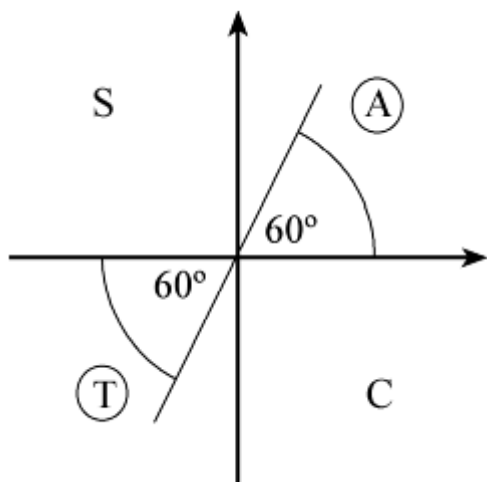

$$X = 240^\circ, 420^\circ$$

$$\text{So } \theta = X - 75^\circ = 165^\circ, 345^\circ$$

(j) Solve $\cos X = -1$ where $X = (50^\circ + 2\theta)$

Interval for X is $50^\circ \leq X \leq 770^\circ$

From the graph of $y = \cos X$, $\cos X = -1$ where

$$X = 180^\circ, 540^\circ$$

$$\text{So } 2\theta + 50^\circ = 180^\circ, 540^\circ$$

$$2\theta = 130^\circ, 490^\circ$$

$$\theta = 65^\circ, 245^\circ$$

© Pearson Education Ltd 2008

Solutionbank C2

Edexcel Modular Mathematics for AS and A-Level

Trigonometrical identities and simple equations

Exercise C, Question 2

Question:

Solve each of the following equations, in the interval given.
Give your answers to 3 significant figures where appropriate.

(a) $\sin \left(\theta - 10^\circ \right) = -\frac{\sqrt{3}}{2}, 0 < \theta \leq 360^\circ$

(b) $\cos (70 - x)^\circ = 0.6, -180 < x \leq 180$

(c) $\tan (3x + 25)^\circ = -0.51, -90 < x \leq 180$

(d) $5 \sin 4\theta + 1 = 0, -90^\circ \leq \theta \leq 90^\circ$

Solution:

(a) Solve $\sin X = -\frac{\sqrt{3}}{2}$ where $X = (\theta - 10^\circ)$

Interval for X is $-10^\circ < X \leq 350^\circ$

First solution is $\sin^{-1} \left(-\frac{\sqrt{3}}{2} \right) = -60^\circ$ (not in interval)

As $\sin X$ is -ve, X is in the 3rd and 4th quadrants.

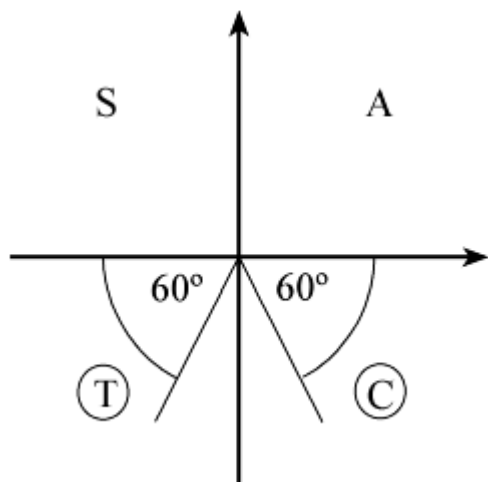

Read off solutions in the interval $-10^\circ < X \leq 350^\circ$

$X = 240^\circ, 300^\circ$

So $\theta = X + 10^\circ = 250^\circ, 310^\circ$

(b) Solve $\cos X^\circ = 0.6$ where $X = (70 - x)$

Interval for X is $180 + 70 > X \geq -180 + 70$ i.e. $-110 \leq X < 250$

First solution is $\cos^{-1} (0.6) = 53.1^\circ$

As $\cos X^\circ$ is +ve, X is in the 1st and 4th quadrants.

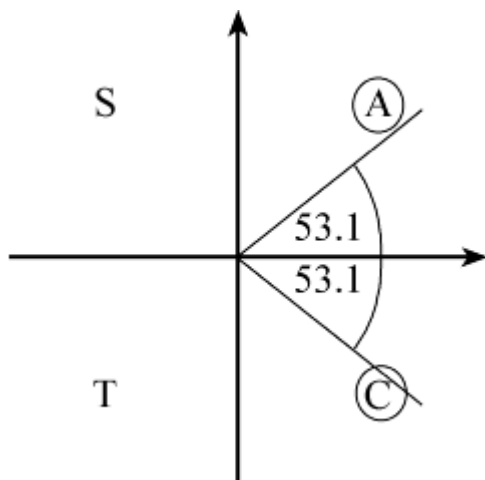

$$X = -53.1, +53.1$$

$$\text{So } x = 70 - X = 16.9, 123 \text{ (3 s.f.)}$$

(c) Solve $\tan X^\circ = -0.51$ where $X = 3x + 25$

Interval for x is $-90 < x \leq 180$

So interval for X is $-245 < X \leq 565$

First solution is $\tan^{-1}(-0.51) = -27.0$

As $\tan X$ is -ve, X is in the 2nd and 4th quadrants.

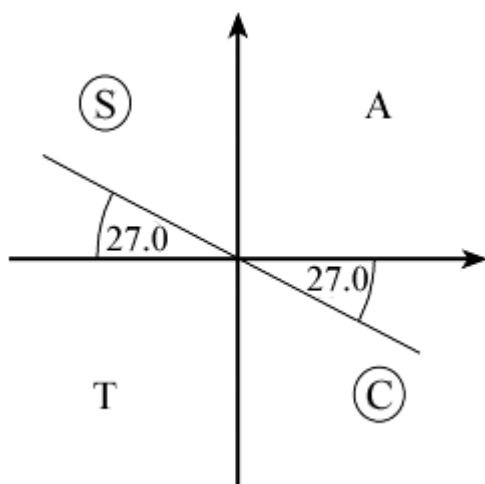

Read off solutions in the interval $-245 < X \leq 565$

$$X = -207, -27, 153, 333, 513$$

$$3x + 25 = -207, -27, 153, 333, 513$$

$$3x = -232, -52, 128, 308, 488$$

$$\text{So } x = -77.3, -17.3, 42.7, 103, 163$$

(d) $5 \sin 4\theta + 1 = 0$

$$5 \sin 4\theta = -1$$

$$\sin 4\theta = -0.2$$

Solve $\sin X = -0.2$ where $X = 4\theta$

Interval for X is $-360^\circ \leq X \leq 360^\circ$

First solution is $\sin^{-1}(-0.2) = -11.5^\circ$

As $\sin X$ is -ve, X is in the 3rd and 4th quadrants.

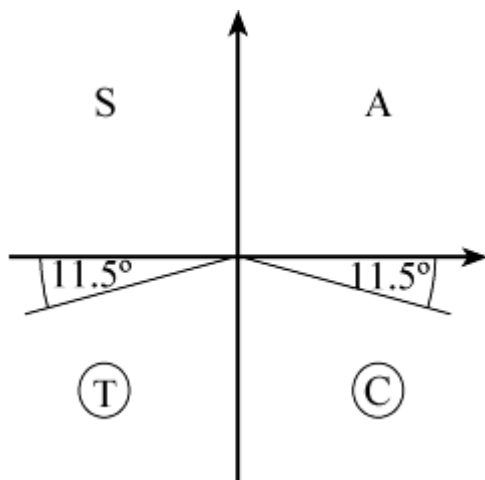

Read off solutions in the interval $-360^\circ \leq X \leq 360^\circ$

$$X = -168.5^\circ, -11.5^\circ, 191.5^\circ, 348.5^\circ$$

$$\text{So } \theta = \frac{X}{4} = -42.1^\circ, -2.88^\circ, 47.9^\circ, 87.1^\circ$$

© Pearson Education Ltd 2008

Solutionbank C2

Edexcel Modular Mathematics for AS and A-Level

Trigonometrical identities and simple equations

Exercise C, Question 3

Question:

Solve the following equations for θ , in the intervals indicated. Give your answers in radians.

$$(a) \sin \left(\theta - \frac{\pi}{6} \right) = -\frac{1}{\sqrt{2}}, \quad -\pi < \theta \leq \pi$$

$$(b) \cos (2\theta + 0.2) = -0.2, \quad -\frac{\pi}{2} \leq \theta \leq \frac{\pi}{2}$$

$$(c) \tan \left(2\theta + \frac{\pi}{4} \right) = 1, \quad 0 \leq \theta \leq 2\pi$$

$$(d) \sin \left(\theta + \frac{\pi}{3} \right) = \tan \frac{\pi}{6}, \quad 0 \leq \theta \leq 2\pi$$

Solution:

$$(a) \text{ Solve } \sin X = -\frac{1}{\sqrt{2}} \text{ where } X = \theta - \frac{\pi}{6}$$

$$\text{Interval for } X \text{ is } -\frac{7\pi}{6} \leq X \leq \frac{5\pi}{6}$$

$$\text{First solution is } X = \sin^{-1} \left(-\frac{1}{\sqrt{2}} \right) = -\frac{\pi}{4}$$

As $\sin X$ is -ve, X is in the 3rd and 4th quadrants.

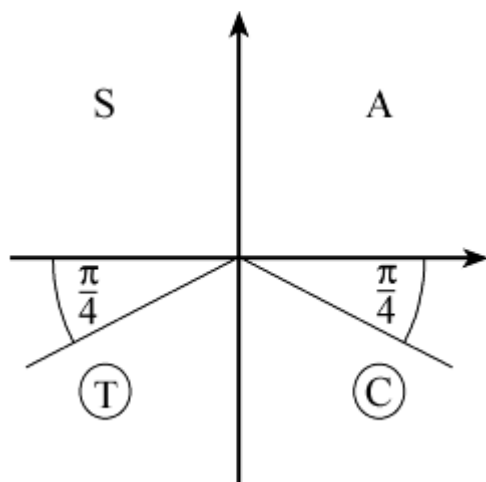

Read off solutions for X in the interval $-\frac{7\pi}{6} \leq X \leq \frac{5\pi}{6}$

$$X = -\frac{3\pi}{4}, \quad -\frac{\pi}{4}$$

$$\text{So } \theta = X + \frac{\pi}{6} = \frac{\pi}{6} - \frac{3\pi}{4}, \frac{\pi}{6} - \frac{\pi}{4} = -\frac{7\pi}{12}, -\frac{\pi}{12}$$

(b) Solve $\cos X = -0.2$ where $X = 2\theta + 0.2$ radians

Interval for X is $-\pi + 0.2 \leq X \leq \pi + 0.2$ i.e. $-2.94 \leq X \leq 3.34$

First solution is $X = \cos^{-1}(-0.2) = 1.77 \dots$ radians

As $\cos X$ is $-ve$, X is in the 2nd and 3rd quadrants.

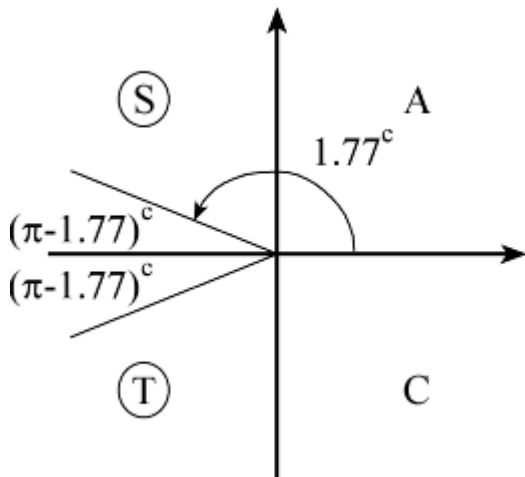

Read off solutions for X in the interval $-2.94 \leq X \leq 3.34$

$$X = -1.77, +1.77 \text{ radians}$$

$$2\theta + 0.2 = -1.77, +1.77$$

$$2\theta = -1.97, +1.57$$

$$\text{So } \theta = -0.986, 0.786$$

(c) Solve $\tan X = 1$ where $X = 2\theta + \frac{\pi}{4}$

Interval for X is $\frac{\pi}{4} \leq X \leq \frac{17\pi}{4}$

First solution is $X = \tan^{-1} 1 = \frac{\pi}{4}$

As \tan is $+ve$, X is in the 1st and 3rd quadrants.

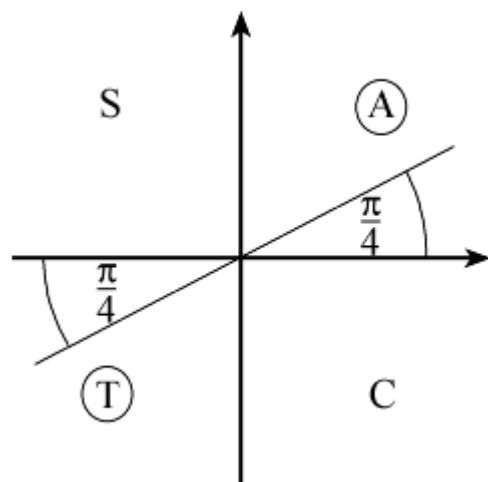

Read off solutions in the interval $\frac{\pi}{4} \leq X \leq \frac{17\pi}{4}$

$$X = \frac{\pi}{4}, \frac{5\pi}{4}, \frac{9\pi}{4}, \frac{13\pi}{4}, \frac{17\pi}{4}$$

$$2\theta + \frac{\pi}{4} = \frac{\pi}{4}, \frac{5\pi}{4}, \frac{9\pi}{4}, \frac{13\pi}{4}, \frac{17\pi}{4}$$

$$2\theta = 0, \pi, 2\pi, 3\pi, 4\pi$$

$$\text{So } \theta = 0, \frac{\pi}{2}, \pi, \frac{3\pi}{2}, 2\pi$$

(d) Solve $\sin X = \frac{\sqrt{3}}{3}$ where $X = \theta + \frac{\pi}{3}$

Interval for X is $\frac{\pi}{3} \leq X \leq \frac{7\pi}{3}$ or 1.047 radians $\leq X \leq 7.33$ radians

First solution is $\sin^{-1} \left(\frac{\sqrt{3}}{3} \right) = 0.615$

As $\sin X$ is +ve, X is in the 1st and 2nd quadrants.

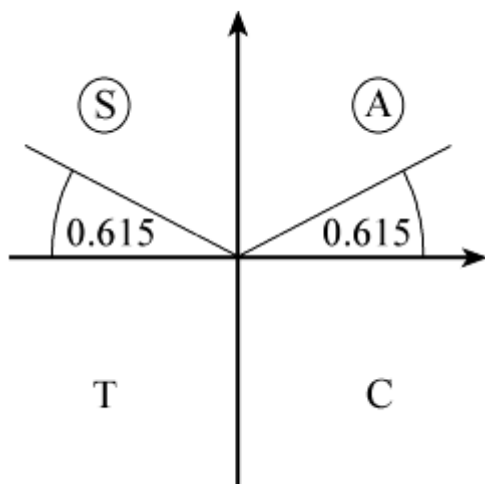

$$X = \pi - 0.615, 2\pi + 0.615 = 2.526, 6.899$$

$$\text{So } \theta = X - \frac{\pi}{3} = 1.48, 5.85$$

Solutionbank C2

Edexcel Modular Mathematics for AS and A-Level

Trigonometrical identities and simple equations

Exercise D, Question 1

Question:

Solve for θ , in the interval $0 \leq \theta \leq 360^\circ$, the following equations.
Give your answers to 3 significant figures where they are not exact.

(a) $4 \cos^2 \theta = 1$

(b) $2 \sin^2 \theta - 1 = 0$

(c) $3 \sin^2 \theta + \sin \theta = 0$

(d) $\tan^2 \theta - 2 \tan \theta - 10 = 0$

(e) $2 \cos^2 \theta - 5 \cos \theta + 2 = 0$

(f) $\sin^2 \theta - 2 \sin \theta - 1 = 0$

(g) $\tan^2 2\theta = 3$

(h) $4 \sin \theta = \tan \theta$

(i) $\sin \theta + 2 \cos^2 \theta + 1 = 0$

(j) $\tan^2 (\theta - 45^\circ) = 1$

(k) $3 \sin^2 \theta = \sin \theta \cos \theta$

(l) $4 \cos \theta (\cos \theta - 1) = -5 \cos \theta$

(m) $4 (\sin^2 \theta - \cos \theta) = 3 - 2 \cos \theta$

(n) $2 \sin^2 \theta = 3 (1 - \cos \theta)$

(o) $4 \cos^2 \theta - 5 \sin \theta - 5 = 0$

(p) $\cos^2 \frac{\theta}{2} = 1 + \sin \frac{\theta}{2}$

Solution:

(a) $4 \cos^2 \theta = 1 \Rightarrow \cos^2 \theta = \frac{1}{4}$

So $\cos \theta = \pm \frac{1}{2}$

Solutions are $60^\circ, 120^\circ, 240^\circ, 300^\circ$

(b) $2 \sin^2 \theta - 1 = 0 \Rightarrow \sin^2 \theta = \frac{1}{2}$

$$\text{So } \sin \theta = \pm \frac{1}{\sqrt{2}}$$

Solutions are in all four quadrants at 45° to the horizontal.

$$\text{So } \theta = 45^\circ, 135^\circ, 225^\circ, 315^\circ$$

$$\text{(c) Factorising, } \sin \theta (3 \sin \theta + 1) = 0$$

$$\text{So } \sin \theta = 0 \text{ or } \sin \theta = -\frac{1}{3}$$

Solutions of $\sin \theta = 0$ are $\theta = 0^\circ, 180^\circ, 360^\circ$ (from graph)

Solutions of $\sin \theta = -\frac{1}{3}$ are $\theta = 199^\circ, 341^\circ$ (3 s.f.) (3rd and 4th quadrants)

$$\text{(d) } \tan^2 \theta - 2 \tan \theta - 10 = 0$$

$$\text{So } \tan \theta = \frac{2 \pm \sqrt{4+40}}{2} = \frac{2 \pm \sqrt{44}}{2} (= -2.3166 \dots \text{ or } 4.3166 \dots)$$

Solutions of $\tan \theta = \frac{2 - \sqrt{44}}{2}$ are in the 2nd and 4th quadrants.

$$\text{So } \theta = 113.35^\circ, 293.3^\circ$$

Solutions of $\tan \theta = \frac{2 + \sqrt{44}}{2}$ are in the 1st and 3rd quadrants.

$$\text{So } \theta = 76.95 \dots^\circ, 256.95 \dots^\circ$$

$$\text{Solution set: } 77.0^\circ, 113^\circ, 257^\circ, 293^\circ$$

$$\text{(e) Factorise LHS of } 2 \cos^2 \theta - 5 \cos \theta + 2 = 0$$

$$(2 \cos \theta - 1)(\cos \theta - 2) = 0$$

$$\text{So } 2 \cos \theta - 1 = 0 \text{ or } \cos \theta - 2 = 0$$

As $\cos \theta \leq 1$, $\cos \theta = 2$ has no solutions.

Solutions of $\cos \theta = \frac{1}{2}$ are $\theta = 60^\circ, 300^\circ$

$$\text{(f) } \sin^2 \theta - 2 \sin \theta - 1 = 0$$

$$\text{So } \sin \theta = \frac{2 \pm \sqrt{8}}{2}$$

$$\text{Solve } \sin \theta = \frac{2 - \sqrt{8}}{2} \text{ as } \frac{2 + \sqrt{8}}{2} > 1$$

$\theta = 204^\circ, 336^\circ$ (solutions are in 3rd and 4th quadrants as $\frac{2 - \sqrt{8}}{2} < 0$)

$$\text{(g) } \tan^2 2\theta = 3 \Rightarrow \tan 2\theta = \pm \sqrt{3}$$

Solve $\tan X = +\sqrt{3}$ and $\tan X = -\sqrt{3}$, where $X = 2\theta$

Interval for X is $0 \leq X \leq 720^\circ$

For $\tan X = \sqrt{3}$, $X = 60^\circ, 240^\circ, 420^\circ, 600^\circ$

$$\text{So } \theta = \frac{X}{2} = 30^\circ, 120^\circ, 210^\circ, 300^\circ$$

For $\tan X = -\sqrt{3}$, $X = 120^\circ, 300^\circ, 480^\circ, 660^\circ$

$$\text{So } \theta = 60^\circ, 150^\circ, 240^\circ, 330^\circ$$

Solution set: $\theta = 30^\circ, 60^\circ, 120^\circ, 150^\circ, 210^\circ, 240^\circ, 300^\circ, 330^\circ$

$$\text{(h) } 4 \sin \theta = \tan \theta$$

$$\text{So } 4 \sin \theta = \frac{\sin \theta}{\cos \theta}$$

$$\Rightarrow 4 \sin \theta \cos \theta = \sin \theta$$

$$\Rightarrow 4 \sin \theta \cos \theta - \sin \theta = 0$$

$$\Rightarrow \sin \theta (4 \cos \theta - 1) = 0$$

$$\text{So } \sin \theta = 0 \text{ or } \cos \theta = \frac{1}{4}$$

Solutions of $\sin \theta = 0$ are $0^\circ, 180^\circ, 360^\circ$

Solutions of $\cos \theta = \frac{1}{4}$ are $\cos^{-1} \left(\frac{1}{4} \right)$ and $360^\circ - \cos^{-1} \left(\frac{1}{4} \right)$

Solution set: $0^\circ, 75.5^\circ, 180^\circ, 284^\circ, 360^\circ$

(i) $\sin \theta + 2 \cos^2 \theta + 1 = 0$

So $\sin \theta + 2(1 - \sin^2 \theta) + 1 = 0$ using $\sin^2 \theta + \cos^2 \theta \equiv 1$

$$\Rightarrow 2 \sin^2 \theta - \sin \theta - 3 = 0$$

$$\Rightarrow (2 \sin \theta - 3)(\sin \theta + 1) = 0$$

So $\sin \theta = -1$ ($\sin \theta = \frac{3}{2}$ has no solution)

$$\Rightarrow \theta = 270^\circ$$

(j) $\tan^2 (\theta - 45^\circ) = 1$

So $\tan (\theta - 45^\circ) = 1$ or $\tan (\theta - 45^\circ) = -1$

So $\theta - 45^\circ = 45^\circ, 225^\circ$ (1st and 3rd quadrants)

or $\theta - 45^\circ = -45^\circ, 135^\circ, 315^\circ$ (2nd and 4th quadrants)

$$\Rightarrow \theta = 0^\circ, 90^\circ, 180^\circ, 270^\circ, 360^\circ$$

(k) $3 \sin^2 \theta = \sin \theta \cos \theta$

$$\Rightarrow 3 \sin^2 \theta - \sin \theta \cos \theta = 0$$

$$\Rightarrow \sin \theta (3 \sin \theta - \cos \theta) = 0$$

So $\sin \theta = 0$ or $3 \sin \theta - \cos \theta = 0$

Solutions of $\sin \theta = 0$ are $\theta = 0^\circ, 180^\circ, 360^\circ$

For $3 \sin \theta - \cos \theta = 0$

$$3 \sin \theta = \cos \theta$$

$$\frac{3 \sin \theta}{3 \cos \theta} = \frac{\cos \theta}{3 \cos \theta}$$

$$\tan \theta = \frac{1}{3}$$

Solutions are $\theta = \tan^{-1} \left(\frac{1}{3} \right)$ and $180^\circ + \tan^{-1} \left(\frac{1}{3} \right) = 18.4^\circ, 198^\circ$

Solution set: $0^\circ, 18.4^\circ, 180^\circ, 198^\circ, 360^\circ$

(l) $4 \cos \theta (\cos \theta - 1) = -5 \cos \theta$

$$\Rightarrow \cos \theta [4(\cos \theta - 1) + 5] = 0$$

$$\Rightarrow \cos \theta (4 \cos \theta + 1) = 0$$

So $\cos \theta = 0$ or $\cos \theta = -\frac{1}{4}$

Solutions of $\cos \theta = 0$ are $90^\circ, 270^\circ$

Solutions of $\cos \theta = -\frac{1}{4}$ are $104^\circ, 256^\circ$ (3 s.f.) (2nd and 3rd quadrants)

Solution set: $90^\circ, 104^\circ, 256^\circ, 270^\circ$

(m) $4 \sin^2 \theta - 4 \cos \theta = 3 - 2 \cos \theta$

$$\Rightarrow 4(1 - \cos^2 \theta) - 4 \cos \theta = 3 - 2 \cos \theta$$

$$\Rightarrow 4 \cos^2 \theta + 2 \cos \theta - 1 = 0$$

$$\text{So } \cos \theta = \frac{-2 \pm \sqrt{20}}{8} \left(= \frac{-1 \pm \sqrt{5}}{4} \right)$$

Solutions of $\cos \theta = \frac{-2 + \sqrt{20}}{8}$ are $72^\circ, 288^\circ$ (1st and 4th quadrants)

Solutions of $\cos \theta = \frac{-2 - \sqrt{20}}{8}$ are $144^\circ, 216^\circ$ (2nd and 3rd quadrants)

Solution set: $72.0^\circ, 144^\circ, 216^\circ, 288^\circ$

$$(n) 2 \sin^2 \theta = 3(1 - \cos \theta)$$

$$\Rightarrow 2(1 - \cos^2 \theta) = 3(1 - \cos \theta)$$

$$\Rightarrow 2(1 - \cos \theta)(1 + \cos \theta) = 3(1 - \cos \theta) \text{ or write as } a \cos^2 \theta + b \cos \theta + c \equiv 0$$

$$\Rightarrow (1 - \cos \theta)[2(1 + \cos \theta) - 3] = 0$$

$$\Rightarrow (1 - \cos \theta)(2 \cos \theta - 1) = 0$$

So $\cos \theta = 1$ or $\cos \theta = \frac{1}{2}$

Solutions are $0^\circ, 60^\circ, 300^\circ, 360^\circ$

$$(o) 4 \cos^2 \theta - 5 \sin \theta - 5 = 0$$

$$\Rightarrow 4(1 - \sin^2 \theta) - 5 \sin \theta - 5 = 0$$

$$\Rightarrow 4 \sin^2 \theta + 5 \sin \theta + 1 = 0$$

$$\Rightarrow (4 \sin \theta + 1)(\sin \theta + 1) = 0$$

So $\sin \theta = -1$ or $\sin \theta = -\frac{1}{4}$

Solution of $\sin \theta = -1$ is $\theta = 270^\circ$

Solutions of $\sin \theta = -\frac{1}{4}$ are $\theta = 194^\circ, 346^\circ$ (3 s.f.) (3rd and 4th quadrants)

Solution set: $194^\circ, 270^\circ, 346^\circ$

$$(p) \cos^2 \frac{\theta}{2} = 1 + \sin \frac{\theta}{2}$$

$$\Rightarrow 1 - \sin^2 \frac{\theta}{2} = 1 + \sin \frac{\theta}{2}$$

$$\Rightarrow \sin^2 \frac{\theta}{2} + \sin \frac{\theta}{2} = 0$$

$$\Rightarrow \sin \frac{\theta}{2} \left(\sin \frac{\theta}{2} + 1 \right) = 0$$

So $\sin \frac{\theta}{2} = 0$ or $\sin \frac{\theta}{2} = -1$

Solve $\sin X = 0$ and $\sin X = -1$ where $X = \frac{\theta}{2}$

Interval for X is $0 \leq X \leq 180^\circ$

$X = 0^\circ, 180^\circ$ ($\sin X = -1$ has no solutions in the interval)

So $\theta = 2X = 0^\circ, 360^\circ$

Solutionbank C2

Edexcel Modular Mathematics for AS and A-Level

Trigonometrical identities and simple equations

Exercise D, Question 2

Question:

Solve for θ , in the interval $-180^\circ \leq \theta \leq 180^\circ$, the following equations.
Give your answers to 3 significant figures where they are not exact.

(a) $\sin^2 2\theta = 1$

(b) $\tan^2 \theta = 2 \tan \theta$

(c) $\cos \theta (\cos \theta - 2) = 1$

(d) $\sin^2 (\theta + 10^\circ) = 0.8$

(e) $\cos^2 3\theta - \cos 3\theta = 2$

(f) $5 \sin^2 \theta = 4 \cos^2 \theta$

(g) $\tan \theta = \cos \theta$

(h) $2 \sin^2 \theta + 3 \cos \theta = 1$

Solution:

(a) Solve $\sin^2 X = 1$ where $X = 2\theta$

Interval for X is $-360^\circ \leq X \leq 360^\circ$

$\sin X = +1$ gives $X = -270^\circ, 90^\circ$

$\sin X = -1$ gives $X = -90^\circ, +270^\circ$

$X = -270^\circ, -90^\circ, +90^\circ, +270^\circ$

So $\theta = \frac{X}{2} = -135^\circ, -45^\circ, +45^\circ, +135^\circ$

(b) $\tan^2 \theta = 2 \tan \theta$

$\Rightarrow \tan^2 \theta - 2 \tan \theta = 0$

$\Rightarrow \tan \theta (\tan \theta - 2) = 0$

So $\tan \theta = 0$ or $\tan \theta = 2$ (1st and 3rd quadrants)

Solutions are $(-180^\circ, 0^\circ, 180^\circ), (-116.6^\circ, 63.4^\circ)$

Solution set: $-180^\circ, -117^\circ, 0^\circ, 63.4^\circ, 180^\circ$

(c) $\cos^2 \theta - 2 \cos \theta = 1$

$\Rightarrow \cos^2 \theta - 2 \cos \theta - 1 = 0$

So $\cos \theta = \frac{2 \pm \sqrt{8}}{2}$

$\Rightarrow \cos \theta = \frac{2 - \sqrt{8}}{2}$ (as $\frac{2 + \sqrt{8}}{2} > 1$)

Solutions are $\pm 114^\circ$ (2nd and 3rd quadrants)

(d) $\sin^2 (\theta + 10^\circ) = 0.8$

$\Rightarrow \sin (\theta + 10^\circ) = +\sqrt{0.8}$ or $\sin (\theta + 10^\circ) = -\sqrt{0.8}$

Either $(\theta + 10^\circ) = 63.4^\circ, 116.6^\circ$ or $(\theta + 10^\circ) = -116.6^\circ, -63.4^\circ$

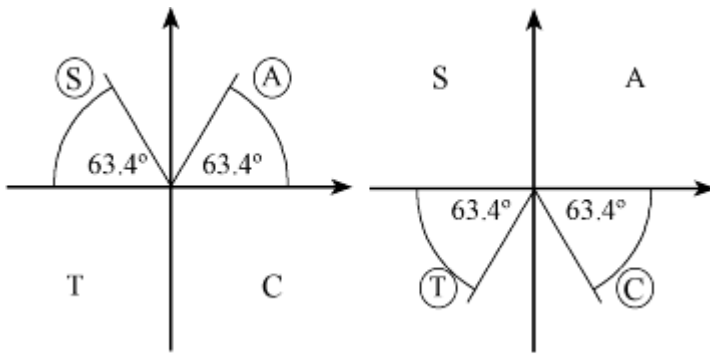

So $\theta = -127^\circ, -73.4^\circ, 53.4^\circ, 107^\circ$ (3 s.f.)

$$(e) \cos^2 3\theta - \cos 3\theta - 2 = 0$$

$$(\cos 3\theta - 2)(\cos 3\theta + 1) = 0$$

$$\text{So } \cos 3\theta = -1 \quad (\cos 3\theta \neq 2)$$

Solve $\cos X = -1$ where $X = 3\theta$

$$\text{Interval for } X \text{ is } -540^\circ \leq X \leq 540^\circ$$

From the graph of $y = \cos X$, $\cos X = -1$ where
 $X = -540^\circ, -180^\circ, 180^\circ, 540^\circ$

$$\text{So } \theta = \frac{X}{3} = -180^\circ, -60^\circ, +60^\circ, +180^\circ$$

$$(f) 5 \sin^2 \theta = 4 \cos^2 \theta$$

$$\Rightarrow \tan^2 \theta = \frac{4}{5} \text{ as } \tan \theta = \frac{\sin \theta}{\cos \theta}$$

$$\text{So } \tan \theta = \pm \sqrt{\frac{4}{5}}$$

There are solutions from each of the quadrants (angle to horizontal is 41.8°)
 $\theta = \pm 138^\circ, \pm 41.8^\circ$

$$(g) \tan \theta = \cos \theta$$

$$\Rightarrow \frac{\sin \theta}{\cos \theta} = \cos \theta$$

$$\Rightarrow \sin \theta = \cos^2 \theta$$

$$\Rightarrow \sin \theta = 1 - \sin^2 \theta$$

$$\Rightarrow \sin^2 \theta + \sin \theta - 1 = 0$$

$$\text{So } \sin \theta = \frac{-1 \pm \sqrt{5}}{2}$$

$$\text{Only solutions from } \sin \theta = \frac{-1 + \sqrt{5}}{2} \text{ (as } \frac{-1 - \sqrt{5}}{2} < -1)$$

Solutions are $\theta = 38.2^\circ, 142^\circ$ (1st and 2nd quadrants)

$$(h) 2 \sin^2 \theta + 3 \cos \theta = 1$$

$$\Rightarrow 2(1 - \cos^2 \theta) + 3 \cos \theta = 1$$

$$\Rightarrow 2 \cos^2 \theta - 3 \cos \theta - 1 = 0$$

$$\text{So } \cos \theta = \frac{3 \pm \sqrt{17}}{4}$$

$$\text{Only solutions of } \cos \theta = \frac{3 - \sqrt{17}}{4} \text{ (as } \frac{3 + \sqrt{17}}{4} > 1)$$

Solutions are $\theta = \pm 106^\circ$ (2nd and 3rd quadrants)

Solutionbank C2

Edexcel Modular Mathematics for AS and A-Level

Trigonometrical identities and simple equations

Exercise D, Question 3

Question:

Solve for x , in the interval $0 \leq x \leq 2\pi$, the following equations.

Give your answers to 3 significant figures unless they can be written in the form $\frac{a}{b}\pi$, where a and b are integers.

(a) $\tan^2 \frac{1}{2}x = 1$

(b) $2 \sin^2 \left(x + \frac{\pi}{3} \right) = 1$

(c) $3 \tan x = 2 \tan^2 x$

(d) $\sin^2 x + 2 \sin x \cos x = 0$

(e) $6 \sin^2 x + \cos x - 4 = 0$

(f) $\cos^2 x - 6 \sin x = 5$

(g) $2 \sin^2 x = 3 \sin x \cos x + 2 \cos^2 x$

Solution:

(a) $\tan^2 \frac{1}{2}x = 1$

$$\Rightarrow \tan \frac{1}{2}x = \pm 1$$

$$\Rightarrow \frac{1}{2}x = \frac{\pi}{4}, \frac{3\pi}{4} \quad \left(0 \leq \frac{1}{2}x \leq \pi \right)$$

So $x = \frac{\pi}{2}, \frac{3\pi}{2}$

(b) $2 \sin^2 \left(x + \frac{\pi}{3} \right) = 1$ for $\frac{\pi}{3} \leq x + \frac{\pi}{3} \leq \frac{7\pi}{3}$

$$\Rightarrow \sin^2 \left(x + \frac{\pi}{3} \right) = \frac{1}{2}$$

So $\sin \left(x + \frac{\pi}{3} \right) = \frac{1}{\sqrt{2}}$ or $\sin \left(x + \frac{\pi}{3} \right) = -\frac{1}{\sqrt{2}}$

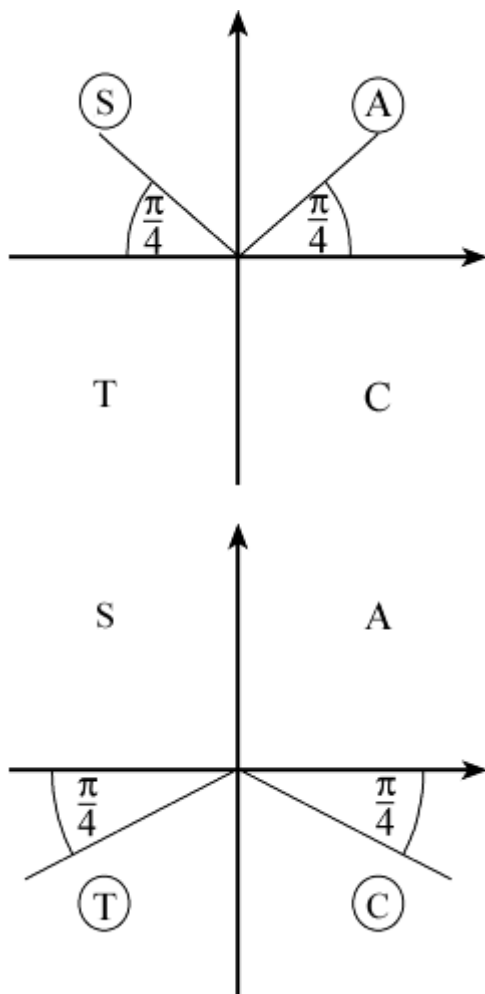

$$x + \frac{\pi}{3} = \frac{3\pi}{4}, \frac{9\pi}{4} \text{ or } x + \frac{\pi}{3} = +\frac{5\pi}{4}, +\frac{7\pi}{4}$$

$$\text{So } x = \frac{3\pi}{4} - \frac{\pi}{3}, \frac{9\pi}{4} - \frac{\pi}{3} \text{ or } x = \frac{5\pi}{4} - \frac{\pi}{3}, \frac{7\pi}{4} - \frac{\pi}{3}$$

$$\text{Solutions are } x = \frac{5\pi}{12}, \frac{11\pi}{12}, \frac{17\pi}{12}, \frac{23\pi}{12}$$

$$\begin{aligned} \text{(c) } 3 \tan x &= 2 \tan^2 x \\ \Rightarrow 2 \tan^2 x - 3 \tan x &= 0 \\ \Rightarrow \tan x (2 \tan x - 3) &= 0 \end{aligned}$$

$$\text{So } \tan x = 0 \text{ or } \tan x = \frac{3}{2}$$

$$x = (0, \pi, 2\pi), (0.983, \pi + 0.983) = 0, 0.983, \pi, 4.12, 2\pi$$

$$\begin{aligned} \text{(d) } \sin^2 x + 2 \sin x \cos x &= 0 \\ \Rightarrow \sin x (\sin x + 2 \cos x) &= 0 \end{aligned}$$

$$\text{So } \sin x = 0 \text{ or } \sin x + 2 \cos x = 0$$

$$\sin x = 0 \text{ gives } x = 0, \pi, 2\pi$$

$$\sin x + 2 \cos x = 0 \Rightarrow \tan x = -2$$

$$\text{Solutions are } 2.03, 5.18 \text{ radians (2nd and 4th quadrants)}$$

$$\text{Solution set: } 0, 2.03, \pi, 5.18, 2\pi$$

$$\begin{aligned} \text{(e) } 6 \sin^2 x + \cos x - 4 &= 0 \\ \Rightarrow 6(1 - \cos^2 x) + \cos x - 4 &= 0 \\ \Rightarrow 6 \cos^2 x - \cos x - 2 &= 0 \end{aligned}$$

$$\Rightarrow (3 \cos x - 2)(2 \cos x + 1) = 0$$

$$\text{So } \cos x = +\frac{2}{3} \text{ or } \cos x = -\frac{1}{2}$$

$$\text{Solutions of } \cos x = +\frac{2}{3} \text{ are } \cos^{-1}\left(\frac{2}{3}\right), 2\pi - \cos^{-1}\left(\frac{2}{3}\right) = 0.841, 5.44$$

$$\text{Solutions of } \cos x = -\frac{1}{2} \text{ are } \cos^{-1}\left(-\frac{1}{2}\right), 2\pi - \cos^{-1}\left(-\frac{1}{2}\right) = \frac{2\pi}{3}, \frac{4\pi}{3}$$

$$\text{Solutions are } 0.841, \frac{2\pi}{3}, \frac{4\pi}{3}, 5.44$$

$$(f) \cos^2 x - 6 \sin x = 5$$

$$\Rightarrow (1 - \sin^2 x) - 6 \sin x = 5$$

$$\Rightarrow \sin^2 x + 6 \sin x + 4 = 0$$

$$\text{So } \sin x = \frac{-6 \pm \sqrt{20}}{2} \quad \left(= -3 \pm \sqrt{5} \right)$$

$$\text{As } \frac{-6 - \sqrt{20}}{2} < -1, \text{ there are no solutions of } \sin x = \frac{-6 - \sqrt{20}}{2}$$

$$\text{Consider solutions of } \sin x = \frac{-6 + \sqrt{20}}{2}$$

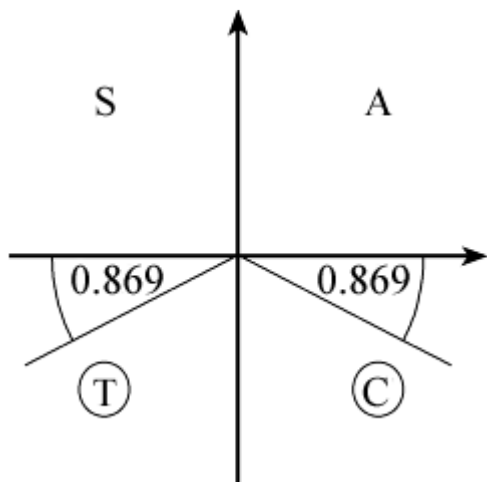

$$\sin^{-1}\left(\frac{-6 + \sqrt{20}}{2}\right) = -0.869 \text{ (not in given interval)}$$

$$\text{Solutions are } \pi + 0.869, 2\pi - 0.869 = 4.01, 5.41$$

$$(g) 2 \sin^2 x - 3 \sin x \cos x - 2 \cos^2 x = 0$$

$$\Rightarrow (2 \sin x + \cos x)(\sin x - 2 \cos x) = 0$$

$$\Rightarrow 2 \sin x + \cos x = 0 \text{ or } \sin x - 2 \cos x = 0$$

$$\text{So } \tan x = -\frac{1}{2} \text{ or } \tan x = 2$$

$$\text{Consider solutions of } \tan x = -\frac{1}{2}$$

$$\text{First solution is } \tan^{-1}\left(-\frac{1}{2}\right) = -0.4636 \dots \text{ (not in interval)}$$

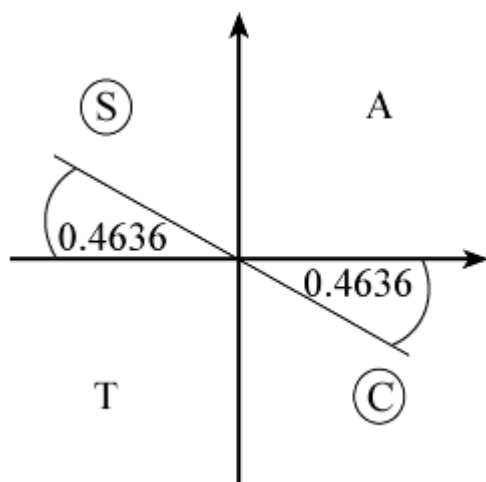

Solutions are $\pi - 0.4636$, $2\pi - 0.4636 = 2.68$, 5.82

Solutions of $\tan x = 2$ are $\tan^{-1} 2$, $\pi + \tan^{-1} 2 = 1.11$, 4.25

Solution set: $x = 1.11$, 2.68 , 4.25 , 5.82 (3 s.f.)

© Pearson Education Ltd 2008

Solutionbank C2

Edexcel Modular Mathematics for AS and A-Level

Trigonometrical identities and simple equations

Exercise E, Question 1

Question:

Given that angle A is obtuse and $\cos A = -\sqrt{\frac{7}{11}}$, show that $\tan A = \frac{-2\sqrt{7}}{7}$.

Solution:

Using $\sin^2 A + \cos^2 A \equiv 1$

$$\sin^2 A + \left(-\sqrt{\frac{7}{11}}\right)^2 = 1$$

$$\sin^2 A = 1 - \frac{7}{11} = \frac{4}{11}$$

$$\sin A = \pm \frac{2}{\sqrt{11}}$$

But A is in the second quadrant (obtuse), so $\sin A$ is +ve.

$$\text{So } \sin A = +\frac{2}{\sqrt{11}}$$

$$\text{Using } \tan A = \frac{\sin A}{\cos A}$$

$$\tan A = \frac{\left(\frac{2}{\sqrt{11}}\right)}{-\sqrt{\frac{7}{11}}} = -\frac{2}{\sqrt{11}} \times \frac{\sqrt{11}}{\sqrt{7}} = -\frac{2}{\sqrt{7}} = -\frac{2\sqrt{7}}{7} \text{ (rationalising the denominator)}$$

Solutionbank C2

Edexcel Modular Mathematics for AS and A-Level

Trigonometrical identities and simple equations

Exercise E, Question 2

Question:

Given that angle B is reflex and $\tan B = + \frac{\sqrt{21}}{2}$, find the exact value of: (a) $\sin B$, (b) $\cos B$.

Solution:

Draw a right-angled triangle with an angle ϕ where $\tan \phi = + \frac{\sqrt{21}}{2}$.

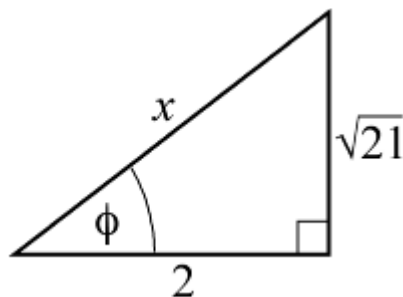

Using Pythagoras' Theorem to find the hypotenuse:

$$x^2 = 2^2 + (\sqrt{21})^2 = 4 + 21 = 25$$

So $x = 5$

$$(a) \sin \phi = \frac{\sqrt{21}}{5}$$

As B is reflex and $\tan B$ is +ve, B is in the third quadrant.

$$\text{So } \sin B = -\sin \phi = -\frac{\sqrt{21}}{5}$$

$$(b) \text{ From the diagram } \cos \phi = \frac{2}{5}$$

$$B \text{ is in the third quadrant, so } \cos B = -\cos \phi = -\frac{2}{5}$$

Solutionbank C2

Edexcel Modular Mathematics for AS and A-Level

Trigonometrical identities and simple equations

Exercise E, Question 3

Question:

(a) Sketch the graph of $y = \sin (x + 60)^\circ$, in the interval $-360 \leq x \leq 360$, giving the coordinates of points of intersection with the axes.

(b) Calculate the values of the x -coordinates of the points in which the line $y = \frac{1}{2}$ intersects the curve.

Solution:

(a) The graph of $y = \sin (x + 60)^\circ$ is the graph of $y = \sin x^\circ$ translated by 60 to the left.

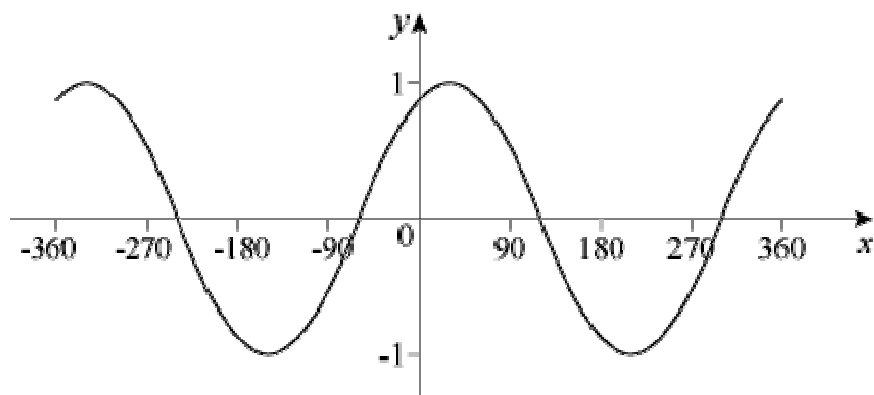

The curve meets the x -axis at $(-240, 0)$, $(-60, 0)$, $(120, 0)$ and $(300, 0)$

The curve meets the y -axis, where $x = 0$.

$$\text{So } y = \sin 60^\circ = \frac{\sqrt{3}}{2}$$

$$\text{Coordinates are } \left(0, \frac{\sqrt{3}}{2} \right)$$

(b) The line meets the curve where $\sin (x + 60)^\circ = \frac{1}{2}$

Let $(x + 60) = X$ and solve $\sin X^\circ = \frac{1}{2}$ where $-300 \leq X \leq 420$

$$\sin X^\circ = \frac{1}{2}$$

First solution is $X = 30$ (your calculator solution)

As $\sin X$ is +ve, X is in the 1st and 2nd quadrants.

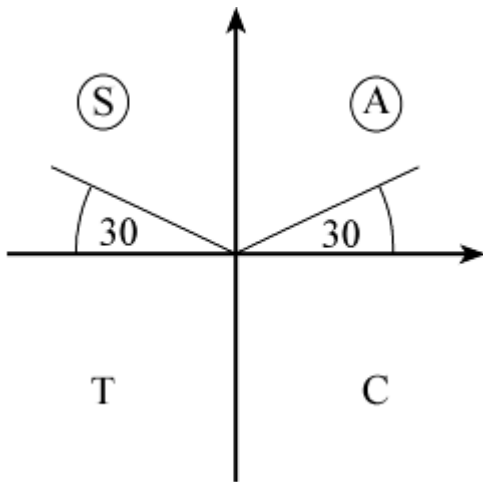

Read off all solutions in the interval $-300 \leq X \leq 420$

$$X = -210, 30, 150, 390$$

$$x + 60 = -210, 30, 150, 390$$

$$\text{So } x = -270, -30, 90, 330$$

© Pearson Education Ltd 2008

Solutionbank C2

Edexcel Modular Mathematics for AS and A-Level

Trigonometrical identities and simple equations

Exercise E, Question 4

Question:

Simplify the following expressions:

(a) $\cos^4 \theta - \sin^4 \theta$

(b) $\sin^2 3\theta - \sin^2 3\theta \cos^2 3\theta$

(c) $\cos^4 \theta + 2 \sin^2 \theta \cos^2 \theta + \sin^4 \theta$

Solution:

(a) Factorise $\cos^4 \theta - \sin^4 \theta$ (difference of two squares)

$$\cos^4 \theta - \sin^4 \theta = (\cos^2 \theta + \sin^2 \theta) (\cos^2 \theta - \sin^2 \theta) = (1) (\cos^2 \theta - \sin^2 \theta) \text{ (as } \sin^2 \theta + \cos^2 \theta \equiv 1)$$

$$\text{So } \cos^4 \theta - \sin^4 \theta = \cos^2 \theta - \sin^2 \theta$$

(b) Factorise $\sin^2 3\theta - \sin^2 3\theta \cos^2 3\theta$

$$\sin^2 3\theta - \sin^2 3\theta \cos^2 3\theta$$

$$= \sin^2 3\theta (1 - \cos^2 3\theta) \text{ use } \sin^2 3\theta + \cos^2 3\theta \equiv 1$$

$$= \sin^2 3\theta (\sin^2 3\theta)$$

$$= \sin^4 3\theta$$

$$(c) \cos^4 \theta + 2 \sin^2 \theta \cos^2 \theta + \sin^4 \theta = (\cos^2 \theta + \sin^2 \theta)^2 = 1$$

$$\text{since } \sin^2 \theta + \cos^2 \theta \equiv 1$$

Solutionbank C2

Edexcel Modular Mathematics for AS and A-Level

Trigonometrical identities and simple equations

Exercise E, Question 5

Question:

- (a) Given that $2(\sin x + 2 \cos x) = \sin x + 5 \cos x$, find the exact value of $\tan x$.
- (b) Given that $\sin x \cos y + 3 \cos x \sin y = 2 \sin x \sin y - 4 \cos x \cos y$, express $\tan y$ in terms of $\tan x$.

Solution:

$$\begin{aligned} \text{(a)} \quad & 2(\sin x + 2 \cos x) = \sin x + 5 \cos x \\ \Rightarrow & 2 \sin x + 4 \cos x = \sin x + 5 \cos x \\ \Rightarrow & 2 \sin x - \sin x = 5 \cos x - 4 \cos x \\ \Rightarrow & \sin x = \cos x \text{ divide both sides by } \cos x \end{aligned}$$

$$\text{So } \tan x = 1$$

$$\begin{aligned} \text{(b)} \quad & \sin x \cos y + 3 \cos x \sin y = 2 \sin x \sin y - 4 \cos x \cos y \\ \Rightarrow & \frac{\sin x \cos y}{\cos x \cos y} + \frac{3 \cos x \sin y}{\cos x \cos y} = \frac{2 \sin x \sin y}{\cos x \cos y} - \frac{4 \cos x \cos y}{\cos x \cos y} \end{aligned}$$

$$\Rightarrow \tan x + 3 \tan y = 2 \tan x \tan y - 4$$

$$\Rightarrow 2 \tan x \tan y - 3 \tan y = 4 + \tan x$$

$$\Rightarrow \tan y (2 \tan x - 3) = 4 + \tan x$$

$$\text{So } \tan y = \frac{4 + \tan x}{2 \tan x - 3}$$

Solutionbank C2

Edexcel Modular Mathematics for AS and A-Level

Trigonometrical identities and simple equations

Exercise E, Question 6

Question:

Show that, for all values of θ :

(a) $(1 + \sin \theta)^2 + \cos^2 \theta = 2(1 + \sin \theta)$

(b) $\cos^4 \theta + \sin^2 \theta = \sin^4 \theta + \cos^2 \theta$

Solution:

(a) LHS = $(1 + 2 \sin \theta + \sin^2 \theta) + \cos^2 \theta$
= $1 + 2 \sin \theta + 1$ since $\sin^2 \theta + \cos^2 \theta \equiv 1$
= $2 + 2 \sin \theta$
= $2(1 + \sin \theta)$
= RHS

(b) LHS = $\cos^4 \theta + \sin^2 \theta$
= $(\cos^2 \theta)^2 + \sin^2 \theta$
= $(1 - \sin^2 \theta)^2 + \sin^2 \theta$ since $\sin^2 \theta + \cos^2 \theta \equiv 1$
= $1 - 2 \sin^2 \theta + \sin^4 \theta + \sin^2 \theta$
= $(1 - \sin^2 \theta) + \sin^4 \theta$
= $\cos^2 \theta + \sin^4 \theta$ using $\sin^2 \theta + \cos^2 \theta \equiv 1$
= RHS

© Pearson Education Ltd 2008

Solutionbank C2

Edexcel Modular Mathematics for AS and A-Level

Trigonometrical identities and simple equations

Exercise E, Question 7

Question:

Without attempting to solve them, state how many solutions the following equations have in the interval $0 \leq \theta \leq 360^\circ$. Give a brief reason for your answer.

(a) $2 \sin \theta = 3$

(b) $\sin \theta = -\cos \theta$

(c) $2 \sin \theta + 3 \cos \theta + 6 = 0$

(d) $\tan \theta + \frac{1}{\tan \theta} = 0$

Solution:

(a) $\sin \theta = \frac{3}{2}$ has no solutions as $-1 \leq \sin \theta \leq 1$

(b) $\sin \theta = -\cos \theta$
 $\Rightarrow \tan \theta = -1$

Look at graph of $y = \tan \theta$ in the interval $0 \leq \theta \leq 360^\circ$.
 There are 2 solutions

(c) The minimum value of $2 \sin \theta$ is -2

The minimum value of $3 \cos \theta$ is -3

Each minimum value is for a different θ .

So the minimum value of $2 \sin \theta + 3 \cos \theta > -5$.

There are no solutions of $2 \sin \theta + 3 \cos \theta + 6 = 0$ as the LHS can never be zero.

(d) Solving $\tan \theta + \frac{1}{\tan \theta} = 0$ is equivalent to solving $\tan^2 \theta = -1$, which has no real solutions, so there are no solutions.

Solutionbank C2

Edexcel Modular Mathematics for AS and A-Level

Trigonometrical identities and simple equations

Exercise E, Question 8

Question:

- (a) Factorise $4xy - y^2 + 4x - y$.
- (b) Solve the equation $4 \sin \theta \cos \theta - \cos^2 \theta + 4 \sin \theta - \cos \theta = 0$, in the interval $0 \leq \theta \leq 360^\circ$.

Solution:

(a) $4xy - y^2 + 4x - y \equiv y(4x - y) + (4x - y) = (4x - y)(y + 1)$

(b) Using (a) with $x = \sin \theta$, $y = \cos \theta$
 $4 \sin \theta \cos \theta - \cos^2 \theta + 4 \sin \theta - \cos \theta = 0$
 $\Rightarrow (4 \sin \theta - \cos \theta)(\cos \theta + 1) = 0$

So $4 \sin \theta - \cos \theta = 0$ or $\cos \theta + 1 = 0$

$4 \sin \theta - \cos \theta = 0 \Rightarrow \tan \theta = \frac{1}{4}$

Calculator solution is $\theta = 14.0^\circ$

$\tan \theta$ is +ve so θ is in the 1st and 3rd quadrants

So $\theta = 14.0^\circ, 194^\circ$

$\cos \theta + 1 = 0 \Rightarrow \cos \theta = -1$

So $\theta = +180^\circ$ (from graph)

Solutions are $\theta = 14.0^\circ, 180^\circ, 194^\circ$

Solutionbank C2

Edexcel Modular Mathematics for AS and A-Level

Trigonometrical identities and simple equations

Exercise E, Question 9

Question:

- (a) Express $4 \cos 3\theta^\circ - \sin (90 - 3\theta)^\circ$ as a single trigonometric function.
- (b) Hence solve $4 \cos 3\theta^\circ - \sin (90 - 3\theta)^\circ = 2$ in the interval $0 \leq \theta \leq 360$. Give your answers to 3 significant figures.

Solution:

(a) As $\sin (90 - \theta)^\circ \equiv \cos \theta^\circ$, $\sin (90 - 3\theta)^\circ \equiv \cos 3\theta^\circ$
 So $4 \cos 3\theta^\circ - \sin (90 - 3\theta)^\circ = 4 \cos 3\theta^\circ - \cos 3\theta^\circ = 3 \cos 3\theta^\circ$

(b) Using (a) $4 \cos 3\theta^\circ - \sin (90 - 3\theta)^\circ = 2$
 is equivalent to $3 \cos 3\theta^\circ = 2$

$$\text{so } \cos 3\theta^\circ = \frac{2}{3}$$

Let $X = 3\theta$ and solve $\cos X^\circ = \frac{2}{3}$ in the interval $0 \leq X \leq 1080$

The calculator solution is $X = 48.19$

As $\cos X^\circ$ is +ve, X is in the 1st and 4th quadrant.

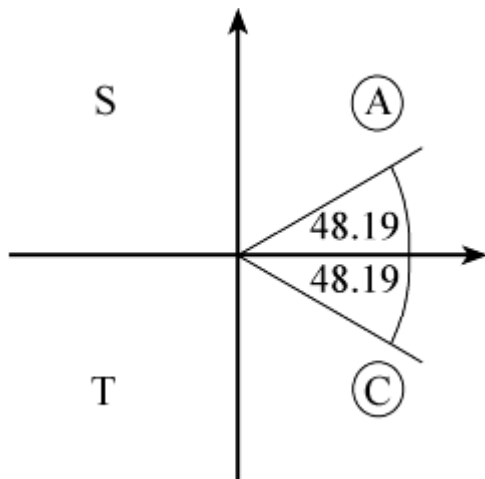

Read off all solutions in the interval $0 \leq X \leq 1080$

$$X = 48.19, 311.81, 408.19, 671.81, 768.19, 1031.81$$

$$\text{So } \theta = \frac{1}{3}X = 16.1, 104, 136, 224, 256, 344 \text{ (3 s.f.)}$$

Solutionbank C2

Edexcel Modular Mathematics for AS and A-Level

Trigonometrical identities and simple equations

Exercise E, Question 10

Question:

Find, in radians to two decimal places, the value of x in the interval $0 \leq x \leq 2\pi$, for which $3 \sin^2 x + \sin x - 2 = 0$. [E]

Solution:

$$3 \sin^2 x + \sin x - 2 = 0$$
$$(3 \sin x - 2)(\sin x + 1) = 0 \text{ factorising}$$

$$\text{So } \sin x = \frac{2}{3} \text{ or } \sin x = -1$$

For $\sin x = \frac{2}{3}$ your calculator answer is 0.73 (2 d.p.)

As $\sin x$ is +ve, x is in the 1st and 2nd quadrants.
So second solution is $(\pi - 0.73) = 2.41$ (2 d.p.)

For $\sin x = -1$, $x = \frac{3\pi}{2} = 4.71$ (2 d.p.)

So $x = 0.73, 2.41, 4.71$

Solutionbank C2

Edexcel Modular Mathematics for AS and A-Level

Trigonometrical identities and simple equations

Exercise E, Question 11

Question:

Given that $2 \sin 2\theta = \cos 2\theta$:

(a) Show that $\tan 2\theta = 0.5$.

(b) Hence find the value of θ , to one decimal place, in the interval $0 \leq \theta < 360^\circ$ for which $2 \sin 2\theta = \cos 2\theta$. **[E]**

Solution:

(a) $2 \sin 2\theta = \cos 2\theta$

$$\Rightarrow \frac{2 \sin 2\theta}{\cos 2\theta} = 1$$

$$\Rightarrow 2 \tan 2\theta = 1 \quad \tan 2\theta = \frac{\sin 2\theta}{\cos 2\theta}$$

So $\tan 2\theta = 0.5$

(b) Solve $\tan 2\theta = 0.5$ in the interval $0 \leq \theta < 360$
or $\tan X = 0.5$ where $X = 2\theta$, $0 \leq X < 720$

The calculator solution for $\tan^{-1} 0.5 = 26.57$

As $\tan X$ is +ve, X is in the 1st and 3rd quadrants.

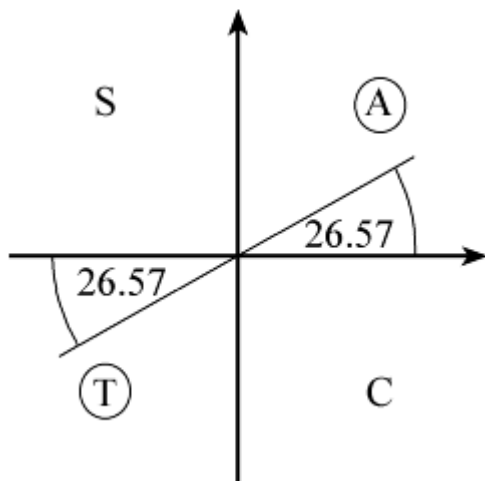

Read off solutions for X in the interval $0 \leq X < 720$

$X = 26.57, 206.57, 386.57, 566.57$

$X = 2\theta$

So $\theta = \frac{1}{2}X = 13.3, 103.3, 193.3, 283.3$ (1 d.p.)

Solutionbank C2

Edexcel Modular Mathematics for AS and A-Level

Trigonometrical identities and simple equations

Exercise E, Question 12

Question:

Find all the values of θ in the interval $0 \leq \theta < 360$ for which:

(a) $\cos (\theta + 75)^\circ = 0.5$.

(b) $\sin 2\theta^\circ = 0.7$, giving your answers to one decimal place. [E]

Solution:

(a) $\cos (\theta + 75)^\circ = 0.5$

Solve $\cos X^\circ = 0.5$ where $X = \theta + 75$, $75 \leq X < 435$

Your calculator solution for X is 60

As $\cos X$ is +ve, X is in the 1st and 4th quadrants.

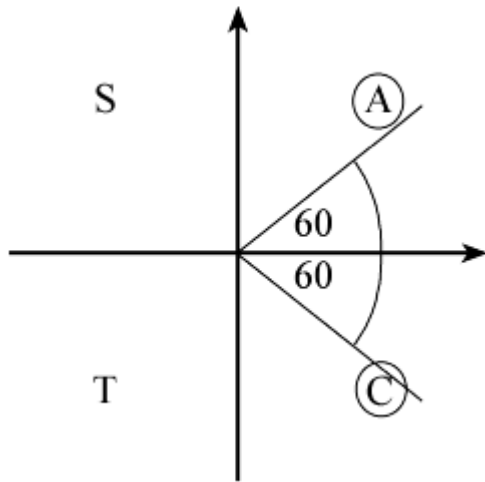

Read off all solutions in the interval $75 \leq X < 435$

$$X = 300, 420$$

$$\theta + 75 = 300, 420$$

$$\text{So } \theta = 225, 345$$

(b) $\sin 2\theta^\circ = 0.7$ in the interval $0 \leq \theta < 360$

Solve $\sin X^\circ = 0.7$ where $X = 2\theta$, $0 \leq X < 720$

Your calculator solution is 44.4

As $\sin X$ is +ve, X is in the 1st and 2nd quadrants.

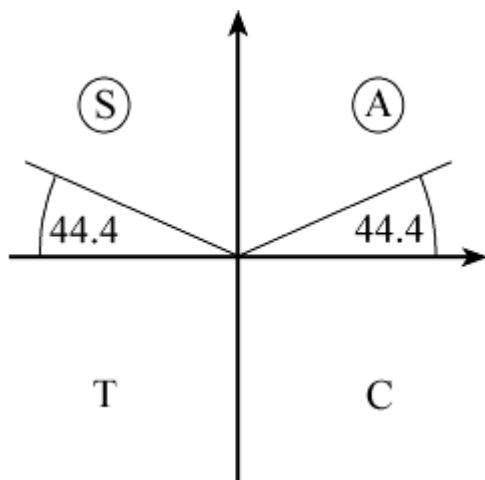

Read off solutions in the interval $0 \leq X < 720$

$$X = 44.4, 135.6, 404.4, 495.6$$

$$X = 2\theta$$

$$\text{So } \theta = \frac{1}{2}X = 22.2, 67.8, 202.2, 247.8 \text{ (1 d.p.)}$$

© Pearson Education Ltd 2008

Solutionbank C2

Edexcel Modular Mathematics for AS and A-Level

Trigonometrical identities and simple equations

Exercise E, Question 13

Question:

- (a) Find the coordinates of the point where the graph of $y = 2 \sin \left(2x + \frac{5}{6}\pi \right)$ crosses the y-axis.
- (b) Find the values of x , where $0 \leq x \leq 2\pi$, for which $y = \sqrt{2}$. **[E]**

Solution:

(a) $y = 2 \sin \left(2x + \frac{5}{6}\pi \right)$ crosses the y-axis where $x = 0$

$$\text{So } y = 2 \sin \frac{5}{6}\pi = 2 \times \frac{1}{2} = 1$$

Coordinates are (0, 1)

(b) Solve $2 \sin \left(2x + \frac{5}{6}\pi \right) = \sqrt{2}$ in the interval $0 \leq x \leq 2\pi$

$$\text{So } \sin \left(2x + \frac{5}{6}\pi \right) = \frac{\sqrt{2}}{2}$$

$$\text{or } \sin X = \frac{\sqrt{2}}{2} \text{ where } \frac{5}{6}\pi \leq X \leq 4\frac{5}{6}\pi$$

Your calculator solution is $\frac{\pi}{4}$

As $\sin X$ is +ve, X lies in the 1st and 2nd quadrants.

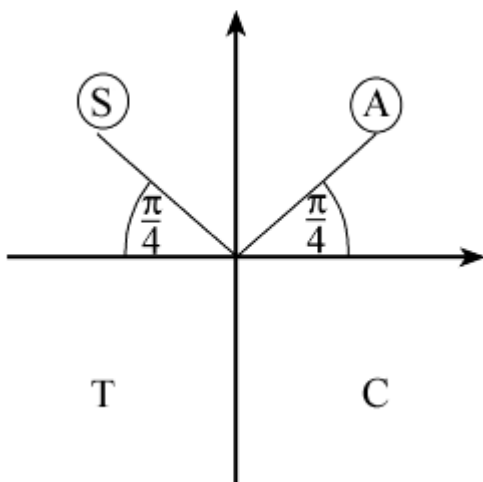

Read off solutions for X in the interval $\frac{5}{6}\pi \leq X \leq 4\frac{5}{6}\pi$

(Note: first value of X in interval is on second revolution.)

$$X = \frac{9\pi}{4}, \frac{11\pi}{4}, \frac{17\pi}{4}, \frac{19\pi}{4}$$

$$2x + \frac{5}{6}\pi = \frac{9\pi}{4}, \frac{11\pi}{4}, \frac{17\pi}{4}, \frac{19\pi}{4}$$

$$2x = \frac{9\pi}{4} - \frac{5\pi}{6}, \frac{11\pi}{4} - \frac{5\pi}{6}, \frac{17\pi}{4} - \frac{5\pi}{6}, \frac{19\pi}{4} - \frac{5\pi}{6}$$

$$2x = \frac{17\pi}{12}, \frac{23\pi}{12}, \frac{41\pi}{12}, \frac{47\pi}{12}$$

$$\text{So } x = \frac{17\pi}{24}, \frac{23\pi}{24}, \frac{41\pi}{24}, \frac{47\pi}{24}$$

© Pearson Education Ltd 2008

Solutionbank C2

Edexcel Modular Mathematics for AS and A-Level

Trigonometrical identities and simple equations

Exercise E, Question 14

Question:

Find, giving your answers in terms of π , all values of θ in the interval $0 < \theta < 2\pi$, for which:

(a) $\tan \left(\theta + \frac{\pi}{3} \right) = 1$

(b) $\sin 2\theta = -\frac{\sqrt{3}}{2}$ [E]

Solution:

(a) $\tan \left(\theta + \frac{\pi}{3} \right) = 1$ in the interval $0 < \theta < 2\pi$

Solve $\tan X = 1$ where $\frac{\pi}{3} < X < \frac{7\pi}{3}$

Calculator solution is $\frac{\pi}{4}$

As $\tan X$ is +ve, X is in the 1st and 3rd quadrants.

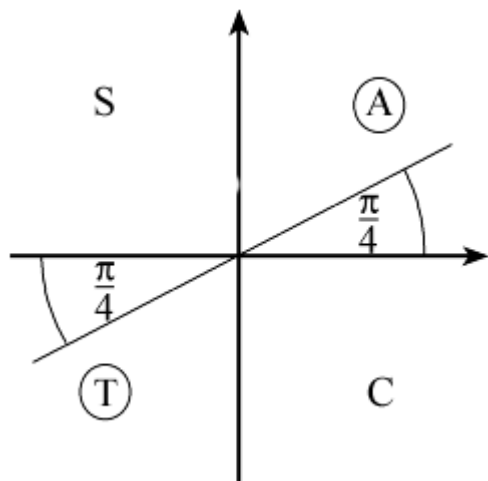

Read off solutions for X in the interval $\frac{\pi}{3} < X < \frac{7\pi}{3}$

$$X = \frac{5\pi}{4}, \frac{9\pi}{4}$$

$$\theta + \frac{\pi}{3} = \frac{5\pi}{4}, \frac{9\pi}{4}$$

$$\text{So } \theta = \frac{5\pi}{4} - \frac{\pi}{3}, \frac{9\pi}{4} - \frac{\pi}{3} = \frac{11\pi}{12}, \frac{23\pi}{12}$$

(b) Solve $\sin X = -\frac{\sqrt{3}}{2}$ where $X = 2\theta$, $0 < \theta < 4\pi$

Calculator answer is $-\frac{\pi}{3}$

As $\sin X$ is $-ve$, X is in the 3rd and 4th quadrants.

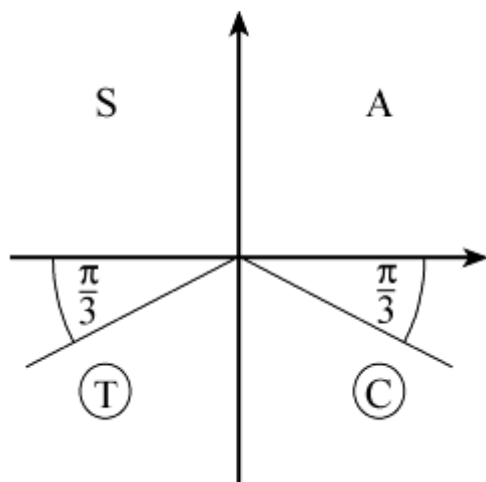

Read off solutions for X in the interval $0 < \theta < 4\pi$

$$X = \frac{4\pi}{3}, \frac{5\pi}{3}, \frac{10\pi}{3}, \frac{11\pi}{3}$$

$$\text{So } \theta = \frac{1}{2}X = \frac{2\pi}{3}, \frac{5\pi}{6}, \frac{5\pi}{3}, \frac{11\pi}{6}$$

© Pearson Education Ltd 2008

Solutionbank C2

Edexcel Modular Mathematics for AS and A-Level

Trigonometrical identities and simple equations

Exercise E, Question 15

Question:

Find the values of x in the interval $0 < x < 270^\circ$ which satisfy the equation

$$\frac{\cos 2x + 0.5}{1 - \cos 2x} = 2$$

Solution:

Multiply both sides of equation by $(1 - \cos 2x)$ (providing $\cos 2x \neq 1$)

(Note: In the interval given $\cos 2x$ is never equal to 1.)

$$\text{So } \cos 2x + 0.5 = 2 - 2 \cos 2x$$

$$\Rightarrow 3 \cos 2x = \frac{3}{2}$$

$$\text{So } \cos 2x = \frac{1}{2}$$

Solve $\cos X = \frac{1}{2}$ where $X = 2x$, $0 < X < 540$

Calculator solution is 60°

As $\cos X$ is +ve, X is in 1st and 4th quadrants.

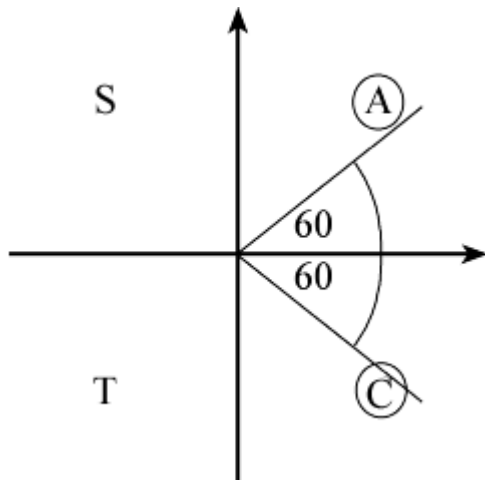

Read off solutions for X in the interval $0 < X < 540$

$$X = 60^\circ, 300^\circ, 420^\circ$$

$$\text{So } x = \frac{1}{2}X = 30^\circ, 150^\circ, 210^\circ$$

Solutionbank C2

Edexcel Modular Mathematics for AS and A-Level

Trigonometrical identities and simple equations

Exercise E, Question 16

Question:

Find, to the nearest integer, the values of x in the interval $0 \leq x < 180^\circ$ for which $3 \sin^2 3x - 7 \cos 3x - 5 = 0$.

[E]

Solution:

Using $\sin^2 3x + \cos^2 3x \equiv 1$

$$3(1 - \cos^2 3x) - 7 \cos 3x - 5 = 0$$

$$\Rightarrow 3 \cos^2 3x + 7 \cos 3x + 2 = 0$$

$$\Rightarrow (3 \cos 3x + 1)(\cos 3x + 2) = 0 \text{ factorising}$$

So $3 \cos 3x + 1 = 0$ or $\cos 3x + 2 = 0$

As $\cos 3x = -2$ has no solutions, the only solutions are from

$$3 \cos 3x + 1 = 0 \text{ or } \cos 3x = -\frac{1}{3}$$

Let $X = 3x$

Solve $\cos X = -\frac{1}{3}$ in the interval $0 \leq X < 540^\circ$

The calculator solution is $X = 109.47^\circ$

As $\cos X$ is $-ve$, X is in the 2nd and 3rd quadrants.

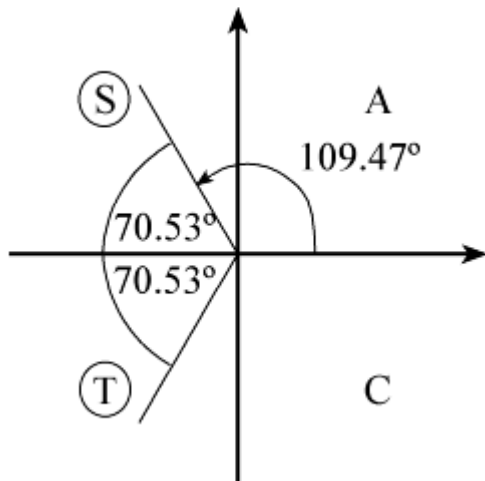

Read off values of X in the interval $0 \leq X < 540^\circ$

$$X = 109.47^\circ, 250.53^\circ, 469.47^\circ$$

$$\text{So } x = \frac{1}{3}X = 36.49^\circ, 83.51^\circ, 156.49^\circ = 36^\circ, 84^\circ, 156^\circ \text{ (to the nearest integer)}$$

Solutionbank C2

Edexcel Modular Mathematics for AS and A-Level

Trigonometrical identities and simple equations

Exercise E, Question 17

Question:

Find, in degrees, the values of θ in the interval $0 \leq \theta < 360^\circ$ for which $2 \cos^2 \theta - \cos \theta - 1 = \sin^2 \theta$.
Give your answers to 1 decimal place, where appropriate.

[E]

Solution:

Using $\sin^2 \theta + \cos^2 \theta \equiv 1$

$$2 \cos^2 \theta - \cos \theta - 1 = 1 - \cos^2 \theta$$

$$\Rightarrow 3 \cos^2 \theta - \cos \theta - 2 = 0$$

$$\Rightarrow (3 \cos \theta + 2)(\cos \theta - 1) = 0$$

So $3 \cos \theta + 2 = 0$ or $\cos \theta - 1 = 0$

For $3 \cos \theta + 2 = 0$, $\cos \theta = -\frac{2}{3}$

Calculator solution is 131.8°

As $\cos \theta$ is -ve, θ is in the 2nd and 3rd quadrants.

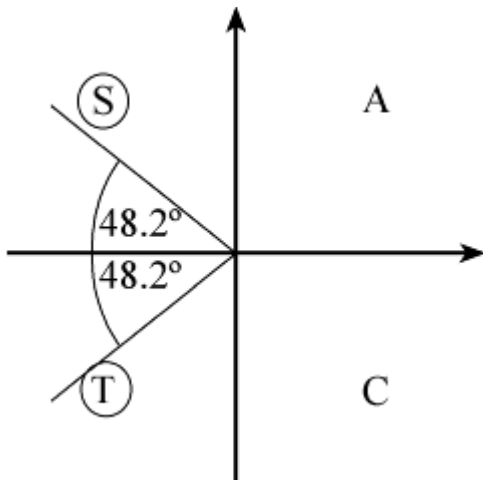

$$\theta = 131.8^\circ, 228.2^\circ$$

For $\cos \theta = 1$, $\theta = 0^\circ$ (see graph and note that 360° is not in given interval)

So solutions are $\theta = 0^\circ, 131.8^\circ, 228.2^\circ$

Solutionbank C2

Edexcel Modular Mathematics for AS and A-Level

Trigonometrical identities and simple equations

Exercise E, Question 18

Question:

Consider the function $f(x)$ defined by

$$f(x) \equiv 3 + 2 \sin (2x + k)^\circ, \quad 0 < x < 360$$

where k is a constant and $0 < k < 360$. The curve with equation $y = f(x)$ passes through the point with coordinates $(15, 3 + \sqrt{3})$.

(a) Show that $k = 30$ is a possible value for k and find the other possible value of k .

(b) Given that $k = 30$, solve the equation $f(x) = 1$.

[E]

Solution:

(a) $(15, 3 + \sqrt{3})$ lies on the curve $y = 3 + 2 \sin (2x + k)^\circ$

$$\text{So } 3 + \sqrt{3} = 3 + 2 \sin (30 + k)^\circ$$

$$2 \sin (30 + k)^\circ = \sqrt{3}$$

$$\sin \left(30 + k \right)^\circ = \frac{\sqrt{3}}{2}$$

A solution, from your calculator, is 60°

So $30 + k = 60$ is a possible result

$$\Rightarrow k = 30$$

As $\sin (30 + k)$ is +ve, answers lie in the 1st and 2nd quadrant.

The other angle is 120° , so $30 + k = 120$

$$\Rightarrow k = 90$$

(b) For $k = 30$, $f(x) = 1$ is

$$3 + 2 \sin (2x + 30)^\circ = 1$$

$$2 \sin (2x + 30)^\circ = -2$$

$$\sin (2x + 30)^\circ = -1$$

Let $X = 2x + 30$

Solve $\sin X^\circ = -1$ in the interval $30 < X < 750$

From the graph of $y = \sin X^\circ$

$$X = +270, 630$$

$$2x + 30 = 270, 630$$

$$2x = 240, 600$$

$$\text{So } x = 120, 300$$

Solutionbank C2

Edexcel Modular Mathematics for AS and A-Level

Trigonometrical identities and simple equations

Exercise E, Question 19

Question:

- (a) Determine the solutions of the equation $\cos (2x - 30)^\circ = 0$ for which $0 \leq x \leq 360$.

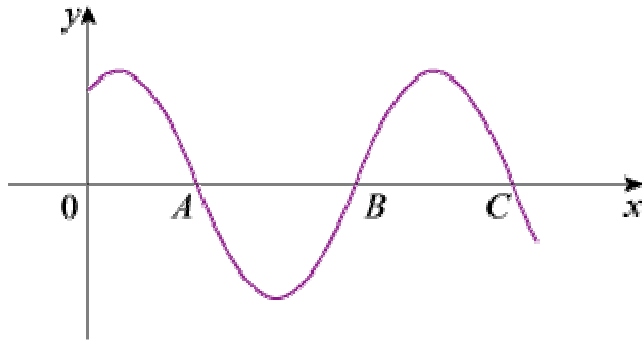

- (b) The diagram shows part of the curve with equation $y = \cos (px - q)^\circ$, where p and q are positive constants and $q < 180$. The curve cuts the x -axis at points A , B and C , as shown.

Given that the coordinates of A and B are $(100, 0)$ and $(220, 0)$ respectively:

- Write down the coordinates of C .
- Find the value of p and the value of q .

[E]

Solution:

- (a) The graph of $y = \cos x^\circ$ crosses x -axis ($y = 0$) where $x = 90, 270, \dots$

Let $X = 2x - 30$

Solve $\cos X^\circ = 0$ in the interval $-30 \leq X \leq 690$

$X = 90, 270, 450, 630$

$2x - 30 = 90, 270, 450, 630$

$2x = 120, 300, 480, 660$

So $x = 60, 150, 240, 330$

- (b) (i) As $AB = BC$, C has coordinates $(340, 0)$

(ii) When $x = 100$, $\cos (100p - q)^\circ = 0$, so $100p - q = 90$ ①

When $x = 220$, $220p - q = 270$ ②

When $x = 340$, $340p - q = 450$ ③

Solving the simultaneous equations ② - ①: $120p = 180 \Rightarrow p = \frac{3}{2}$

Substitute in ①: $150 - q = 90 \Rightarrow q = 60$

Solutionbank C2

Edexcel Modular Mathematics for AS and A-Level

Trigonometrical identities and simple equations

Exercise E, Question 20

Question:

The diagram shows part of the curve with equation $y = f(x)$, where $f(x) = 1 + 2 \sin(px^\circ + q^\circ)$, p and q being positive constants and $q \leq 90$. The curve cuts the y -axis at the point A and the x -axis at the points C and D . The point B is a maximum point on the curve.

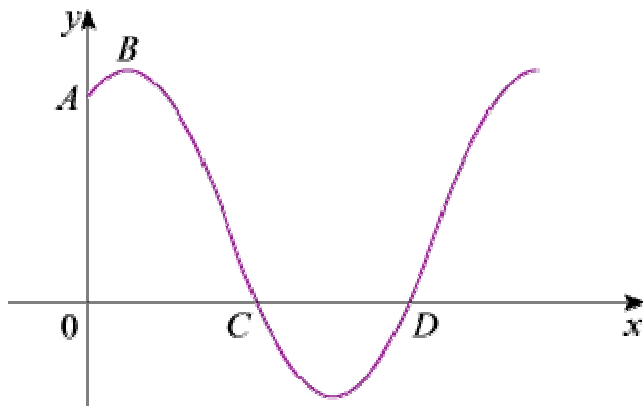

Given that the coordinates of A and C are $(0, 2)$ and $(45, 0)$ respectively:

- Calculate the value of q .
- Show that $p = 4$.
- Find the coordinates of B and D .

[E]

Solution:

(a) Substitute $(0, 2)$ is $y = f(x)$:

$$2 = 1 + 2 \sin q^\circ$$

$$2 \sin q^\circ = +1$$

$$\sin q^\circ = +\frac{1}{2}$$

As $q \leq 90$, $q = 30$

(b) C is where $1 + 2 \sin(px^\circ + q^\circ) = 0$ for the first time.

$$\text{Solve } \sin \left(px^\circ + 30^\circ \right) = -\frac{1}{2} \text{ (use only first solution)}$$

$$45p^\circ + 30^\circ = 210^\circ \quad (x = 45 \text{ at } C)$$

$$45p = 180$$

$$p = 4$$

(c) At B $f(x)$ is a maximum.

$$1 + 2 \sin(4x^\circ + 30^\circ) \text{ is a maximum when } \sin(4x^\circ + 30^\circ) = 1$$

$$\text{So } y \text{ value at } B = 1 + 2 = 3$$

For x value, solve $4x^\circ + 30^\circ = 90^\circ$ (as B is first maximum)

$$\Rightarrow x = 15$$

Coordinates of B are $(15, 3)$.

D is the second x value for which $1 + 2 \sin (4x^\circ + 30^\circ) = 0$

$$\text{Solve } \sin \left(4x^\circ + 30^\circ \right) = -\frac{1}{2} \text{ (use second solution)}$$

$$4x^\circ + 30^\circ = 330^\circ$$

$$4x^\circ = 300^\circ$$

$$x = 75$$

Coordinates of D are $(75, 0)$.

© Pearson Education Ltd 2008

Solutionbank C2

Edexcel Modular Mathematics for AS and A-Level

Integration

Exercise A, Question 1

Question:

Evaluate the following definite integrals:

$$(a) \int_1^2 \left(\frac{2}{x^3} + 3x \right) dx$$

$$(b) \int_0^2 (2x^3 - 4x + 5) dx$$

$$(c) \int_4^9 \left(\sqrt{x} - \frac{6}{x^2} \right) dx$$

$$(d) \int_1^2 \left(6x - \frac{12}{x^4} + 3 \right) dx$$

$$(e) \int_1^8 \left(x^{-\frac{1}{3}} + 2x - 1 \right) dx$$

Solution:

$$\begin{aligned} (a) \int_1^2 \left(\frac{2}{x^3} + 3x \right) dx &= \int_1^2 (2x^{-3} + 3x) dx \\ &= \left[\frac{2x^{-2}}{-2} + \frac{3x^2}{2} \right]_1^2 \\ &= \left[-x^{-2} + \frac{3}{2}x^2 \right]_1^2 \\ &= \left(-\frac{1}{4} + \frac{3}{2} \times 4 \right) - \left(-1 + \frac{3}{2} \right) \\ &= \left(-\frac{1}{4} + 6 \right) - \frac{1}{2} \\ &= 5\frac{1}{4} \end{aligned}$$

$$\begin{aligned} (b) \int_0^2 (2x^3 - 4x + 5) dx &= \left[\frac{2x^4}{4} - \frac{4x^2}{2} + 5x \right]_0^2 \\ &= \left[\frac{x^4}{2} - 2x^2 + 5x \right]_0^2 \end{aligned}$$

$$= \left(\frac{16}{2} - 2 \times 4 + 10 \right) - \left(0 \right)$$

$$= 8 - 8 + 10$$

$$= 10$$

$$(c) \int_4^9 \left(\sqrt{x} - \frac{6}{x^2} \right) dx$$

$$= \int_4^9 \left(x^{\frac{1}{2}} - 6x^{-2} \right) dx$$

$$= \left[\frac{x^{\frac{3}{2}}}{\frac{3}{2}} - \frac{6x^{-1}}{-1} \right]_4^9$$

$$= \left[\frac{2}{3}x^{\frac{3}{2}} + 6x^{-1} \right]_4^9$$

$$= \left(\frac{2}{3} \times 9^{\frac{3}{2}} + \frac{6}{9} \right) - \left(\frac{2}{3} \times 4^{\frac{3}{2}} + \frac{6}{4} \right)$$

$$= \left(\frac{2}{3} \times 3^3 + \frac{2}{3} \right) - \left(\frac{2}{3} \times 2^3 + \frac{3}{2} \right)$$

$$= 18 + \frac{2}{3} - \frac{16}{3} - \frac{3}{2}$$

$$= 16\frac{1}{2} - \frac{14}{3}$$

$$= 11\frac{5}{6}$$

$$(d) \int_1^2 \left(6x - \frac{12}{x^4} + 3 \right) dx$$

$$= \int_1^2 (6x - 12x^{-4} + 3) dx$$

$$= \left[\frac{6x^2}{2} - \frac{12x^{-3}}{-3} + 3x \right]_1^2$$

$$= [3x^2 + 4x^{-3} + 3x]_1^2$$

$$= \left(3 \times 4 + \frac{4}{8} + 6 \right) - \left(3 + 4 + 3 \right)$$

$$= 12 + \frac{1}{2} + 6 - 10$$

$$= 8\frac{1}{2}$$

$$(e) \int_1^8 \left(x^{-\frac{1}{3}} + 2x - 1 \right) dx$$

$$\begin{aligned} &= \left[\frac{x^{\frac{2}{3}}}{\frac{2}{3}} + \frac{2x^2}{2} - x \right]_1^8 \\ &= \left[\frac{3}{2}x^{\frac{2}{3}} + x^2 - x \right]_1^8 \\ &= \left(\frac{3}{2} \times 2^2 + 64 - 8 \right) - \left(\frac{3}{2} + 1 - 1 \right) \\ &= 62 - \frac{3}{2} \\ &= 60 \frac{1}{2} \end{aligned}$$

© Pearson Education Ltd 2008

Solutionbank C2

Edexcel Modular Mathematics for AS and A-Level

Integration

Exercise A, Question 2

Question:

Evaluate the following definite integrals:

$$(a) \int_1^3 \left(\frac{x^3 + 2x^2}{x} \right) dx$$

$$(b) \int_1^4 (\sqrt{x} - 3)^2 dx$$

$$(c) \int_3^6 \left(x - \frac{3}{x} \right)^2 dx$$

$$(d) \int_0^1 x^2 \left(\sqrt{x} + \frac{1}{x} \right) dx$$

$$(e) \int_1^4 \frac{2 + \sqrt{x}}{x^2} dx$$

Solution:

$$\begin{aligned} (a) \int_1^3 \left(\frac{x^3 + 2x^2}{x} \right) dx &= \int_1^3 (x^2 + 2x) dx \\ &= \left[\frac{x^3}{3} + x^2 \right]_1^3 \\ &= \left(\frac{27}{3} + 9 \right) - \left(\frac{1}{3} + 1 \right) \\ &= 18 - \frac{4}{3} \\ &= 16 \frac{2}{3} \end{aligned}$$

$$\begin{aligned} (b) \int_1^4 (\sqrt{x} - 3)^2 dx &= \int_1^4 (x - 6\sqrt{x} + 9) dx \\ &= \int_1^4 \left(x - 6x^{\frac{1}{2}} + 9 \right) dx \\ &= \left[\frac{x^2}{2} - \frac{6x^{\frac{3}{2}}}{\frac{3}{2}} + 9x \right]_1^4 \end{aligned}$$

$$\begin{aligned}
&= \left[\frac{x^2}{2} - 4x^{\frac{3}{2}} + 9x \right]_1^4 \\
&= \left(\frac{16}{2} - 4 \times 2^3 + 36 \right) - \left(\frac{1}{2} - 4 + 9 \right) \\
&= 8 - 32 + 36 - 5 \frac{1}{2} \\
&= 12 - 5 \frac{1}{2} \\
&= 6 \frac{1}{2}
\end{aligned}$$

$$\begin{aligned}
\text{(c) } &\int_3^6 \left(x - \frac{3}{x} \right)^2 dx \\
&= \int_3^6 \left(x^2 - 6 + \frac{9}{x^2} \right) dx \\
&= \int_3^6 (x^2 - 6 + 9x^{-2}) dx \\
&= \left[\frac{x^3}{3} - 6x + \frac{9x^{-1}}{-1} \right]_3^6 \\
&= \left[\frac{x^3}{3} - 6x - 9x^{-1} \right]_3^6 \\
&= \left(\frac{216}{3} - 36 - \frac{9}{6} \right) - \left(\frac{27}{3} - 18 - \frac{9}{3} \right) \\
&= 72 - 36 - \frac{3}{2} - 9 + 18 + 3 \\
&= 48 - \frac{3}{2} \\
&= 46 \frac{1}{2}
\end{aligned}$$

$$\begin{aligned}
\text{(d) } &\int_0^1 x^2 \left(\sqrt{x} + \frac{1}{x} \right) dx \\
&= \int_0^1 \left(x^{\frac{5}{2}} + x \right) dx \\
&= \left[\frac{x^{\frac{7}{2}}}{\frac{7}{2}} + \frac{x^2}{2} \right]_0^1 \\
&= \left[\frac{2}{7} x^{\frac{7}{2}} + \frac{x^2}{2} \right]_0^1 \\
&= \left(\frac{2}{7} + \frac{1}{2} \right) - \left(0 \right) \\
&= \frac{4}{14} + \frac{7}{14}
\end{aligned}$$

$$= \frac{11}{14}$$

$$\begin{aligned}
 \text{(e)} \int_1^4 \left(\frac{2 + \sqrt{x}}{x^2} \right) dx \\
 &= \int_1^4 \left(\frac{2}{x^2} + \frac{1}{x^{\frac{3}{2}}} \right) dx \\
 &= \int_1^4 \left(2x^{-2} + x^{-\frac{3}{2}} \right) dx \\
 &= \left[\frac{2x^{-1}}{-1} + \frac{x^{-\frac{1}{2}}}{-\frac{1}{2}} \right]_1^4 \\
 &= \left[-2x^{-1} - 2x^{-\frac{1}{2}} \right]_1^4 \\
 &= \left(-\frac{2}{4} - \frac{2}{2} \right) - \left(-2 - 2 \right) \\
 &= -1\frac{1}{2} + 4 \\
 &= 2\frac{1}{2}
 \end{aligned}$$

Solutionbank C2

Edexcel Modular Mathematics for AS and A-Level

Integration

Exercise B, Question 1

Question:

Find the area between the curve with equation $y = f(x)$, the x -axis and the lines $x = a$ and $x = b$ in each of the following cases:

(a) $f(x) = 3x^2 - 2x + 2$; $a = 0, b = 2$

(b) $f(x) = x^3 + 4x$; $a = 1, b = 2$

(c) $f(x) = \sqrt{x} + 2x$; $a = 1, b = 4$

(d) $f(x) = 7 + 2x - x^2$; $a = -1, b = 2$

(e) $f(x) = \frac{8}{x^3} + \sqrt{x}$; $a = 1, b = 4$

Solution:

$$\begin{aligned} \text{(a) } A &= \int_0^2 (3x^2 - 2x + 2) \, dx \\ &= \left[\frac{3x^3}{3} - \frac{2x^2}{2} + 2x \right]_0^2 \\ &= [x^3 - x^2 + 2x]_0^2 \\ &= (8 - 4 + 4) - (0) \\ &= 8 \end{aligned}$$

$$\begin{aligned} \text{(b) } A &= \int_1^2 (x^3 + 4x) \, dx \\ &= \left[\frac{x^4}{4} + \frac{4x^2}{2} \right]_1^2 \\ &= \left(\frac{16}{4} + 2 \times 4 \right) - \left(\frac{1}{4} + 2 \right) \\ &= 4 + 8 - 2\frac{1}{4} \\ &= 9\frac{3}{4} \end{aligned}$$

$$\begin{aligned} \text{(c) } A &= \int_1^4 (\sqrt{x} + 2x) \, dx \\ &= \int_1^4 \left(x^{\frac{1}{2}} + 2x \right) \, dx \\ &= \left[\frac{x^{\frac{3}{2}}}{\frac{3}{2}} + x^2 \right]_1^4 \\ &= \left[\frac{2}{3} x^{\frac{3}{2}} + x^2 \right]_1^4 \end{aligned}$$

$$\begin{aligned}
&= \left[\frac{2}{3}x^{\frac{3}{2}} + x^2 \right]_1^4 \\
&= \left(\frac{2}{3} \times 2^3 + 16 \right) - \left(\frac{2}{3} + 1 \right) \\
&= \frac{16}{3} + 16 - \frac{2}{3} - 1 \\
&= 15 + \frac{14}{3} \\
&= 19 \frac{2}{3}
\end{aligned}$$

$$\begin{aligned}
\text{(d) } A &= \int_{-1}^2 (7 + 2x - x^2) \, dx \\
&= \left[7x + x^2 - \frac{x^3}{3} \right]_{-1}^2 \\
&= \left(14 + 4 - \frac{8}{3} \right) - \left(-7 + 1 + \frac{1}{3} \right) \\
&= 18 - \frac{8}{3} + 6 - \frac{1}{3} \\
&= 24 - \frac{9}{3} \\
&= 21
\end{aligned}$$

$$\begin{aligned}
\text{(e) } A &= \int_1^4 \left(\frac{8}{x^3} + \sqrt{x} \right) \, dx \\
&= \int_1^4 \left(8x^{-3} + x^{\frac{1}{2}} \right) \, dx \\
&= \left[\frac{8x^{-2}}{-2} + \frac{x^{\frac{3}{2}}}{\frac{3}{2}} \right]_1^4 \\
&= \left[-4x^{-2} + \frac{2}{3}x^{\frac{3}{2}} \right]_1^4 \\
&= \left(-\frac{4}{16} + \frac{2}{3} \times 2^3 \right) - \left(-4 + \frac{2}{3} \right) \\
&= -\frac{1}{4} + \frac{16}{3} + 4 - \frac{2}{3} \\
&= 3 \frac{3}{4} + 4 \frac{2}{3} \\
&= 8 \frac{5}{12}
\end{aligned}$$

Solutionbank C2

Edexcel Modular Mathematics for AS and A-Level

Integration

Exercise B, Question 2

Question:

The sketch shows part of the curve with equation $y = x(x^2 - 4)$.
Find the area of the shaded region.

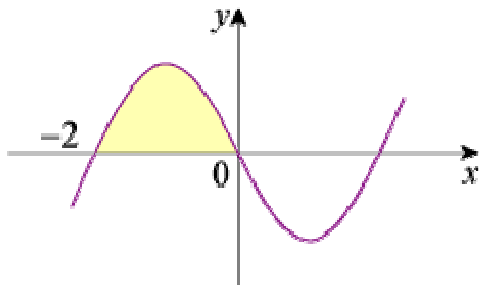

Solution:

$$\begin{aligned}
 A &= \int_{-2}^0 x(x^2 - 4) \, dx \\
 &= \int_{-2}^0 (x^3 - 4x) \, dx \\
 &= \left[\frac{x^4}{4} - \frac{4x^2}{2} \right]_{-2}^0 \\
 &= \left[\frac{x^4}{4} - 2x^2 \right]_{-2}^0 \\
 &= \left(0 \right) - \left(\frac{16}{4} - 2 \times 4 \right) \\
 &= -4 + 8 \\
 &= 4
 \end{aligned}$$

Solutionbank C2

Edexcel Modular Mathematics for AS and A-Level

Integration

Exercise B, Question 3

Question:

The diagram shows a sketch of the curve with equation $y = 3x + \frac{6}{x^2} - 5$, $x > 0$.

The region R is bounded by the curve, the x -axis and the lines $x = 1$ and $x = 3$. Find the area of R .

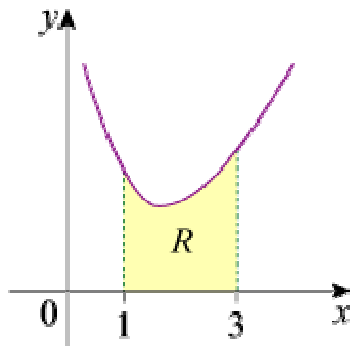

Solution:

$$\begin{aligned}
 A &= \int_1^3 \left(3x + \frac{6}{x^2} - 5 \right) dx \\
 &= \int_1^3 (3x + 6x^{-2} - 5) dx \\
 &= \left[\frac{3x^2}{2} + \frac{6x^{-1}}{-1} - 5x \right]_1^3 \\
 &= \left[\frac{3}{2}x^2 - 6x^{-1} - 5x \right]_1^3 \\
 &= \left(\frac{3}{2} \times 9 - \frac{6}{3} - 15 \right) - \left(\frac{3}{2} - 6 - 5 \right) \\
 &= \frac{27}{2} - 17 - \frac{3}{2} + 11 \\
 &= \frac{24}{2} - 6 \\
 &= 6
 \end{aligned}$$

Solutionbank C2

Edexcel Modular Mathematics for AS and A-Level

Integration

Exercise B, Question 4

Question:

Find the area of the finite region between the curve with equation $y = (3 - x)(1 + x)$ and the x -axis.

Solution:

$y = (3 - x)(1 + x)$ is \cap shaped

$$y = 0 \Rightarrow x = 3, -1$$

$$x = 0 \Rightarrow y = 3$$

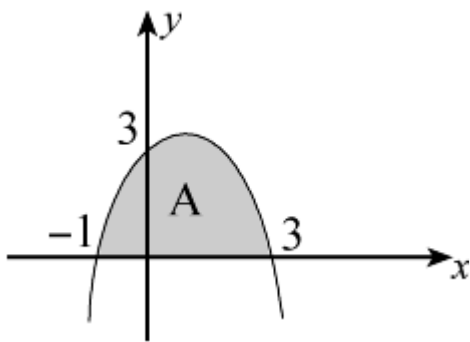

$$\begin{aligned} A &= \int_{-1}^3 (3 - x)(1 + x) \, dx \\ &= \int_{-1}^3 (3 + 2x - x^2) \, dx \\ &= \left[3x + x^2 - \frac{x^3}{3} \right]_{-1}^3 \\ &= \left(9 + 9 - \frac{27}{3} \right) - \left(-3 + 1 + \frac{1}{3} \right) \\ &= 9 + 1 \frac{2}{3} \\ &= 10 \frac{2}{3} \end{aligned}$$

Solutionbank C2

Edexcel Modular Mathematics for AS and A-Level

Integration

Exercise B, Question 5

Question:

Find the area of the finite region between the curve with equation $y = x(x - 4)^2$ and the x -axis.

Solution:

$$y = x(x - 4)^2$$

$$y = 0 \Rightarrow x = 0, 4 \text{ (twice)}$$

Turning point at $(4, 0)$

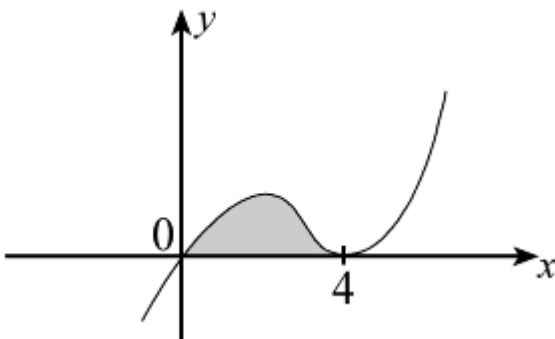

$$\text{Area} = \int_0^4 x(x - 4)^2 dx$$

$$= \int_0^4 x(x^2 - 8x + 16) dx$$

$$= \int_0^4 (x^3 - 8x^2 + 16x) dx$$

$$= \left[\frac{x^4}{4} - \frac{8x^3}{3} + 8x^2 \right]_0^4$$

$$= \left(64 - \frac{8}{3} \times 64 + 128 \right) - \left(0 \right)$$

$$= \frac{64}{3} \text{ or } 21 \frac{1}{3}$$

Solutionbank C2

Edexcel Modular Mathematics for AS and A-Level

Integration

Exercise B, Question 6

Question:

Find the area of the finite region between the curve with equation $y = x^2(2 - x)$ and the x -axis.

Solution:

$$y = x^2(2 - x)$$

$$y = 0 \Rightarrow x = 0 \text{ (twice), } 2$$

Turning point at $(0, 0)$

$$x \rightarrow -\infty, y \rightarrow \infty$$

$$x \rightarrow \infty, y \rightarrow -\infty$$

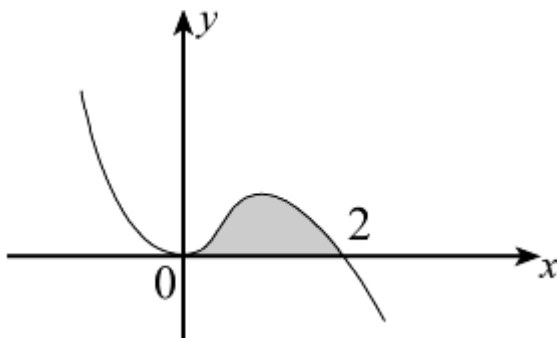

$$\text{Area} = \int_0^2 x^2(2 - x) \, dx$$

$$= \int_0^2 (2x^2 - x^3) \, dx$$

$$= \left[\frac{2x^3}{3} - \frac{x^4}{4} \right]_0^2$$

$$= \left(\frac{16}{3} - \frac{16}{4} \right) - \left(0 \right)$$

$$= \frac{4}{3} \text{ or } 1 \frac{1}{3}$$

© Pearson Education Ltd 2008

Solutionbank C2

Edexcel Modular Mathematics for AS and A-Level

Integration

Exercise C, Question 1

Question:

Sketch the following and find the area of the finite region or regions bounded by the curve and the x -axis:

$$y = x(x + 2)$$

Solution:

$y = x(x + 2)$ is \cup shaped

$$y = 0 \Rightarrow x = 0, -2$$

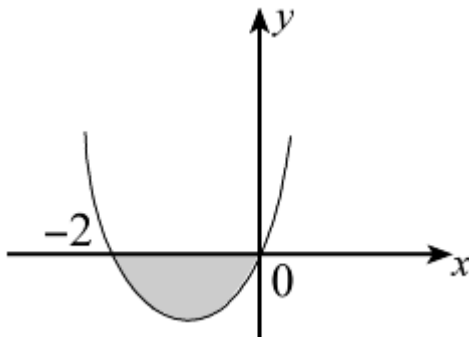

$$\begin{aligned} \text{Area} &= - \int_{-2}^0 x(x + 2) \, dx \\ &= - \int_{-2}^0 (x^2 + 2x) \, dx \\ &= - \left[\frac{x^3}{3} + x^2 \right]_{-2}^0 \\ &= - \left\{ \left(0 \right) - \left(-\frac{8}{3} + 4 \right) \right\} \\ &= - \left(-\frac{4}{3} \right) \\ &= \frac{4}{3} \text{ or } 1\frac{1}{3} \end{aligned}$$

Solutionbank C2

Edexcel Modular Mathematics for AS and A-Level

Integration

Exercise C, Question 2

Question:

Sketch the following and find the area of the finite region or regions bounded by the curve and the x -axis:

$$y = (x + 1)(x - 4)$$

Solution:

$y = (x + 1)(x - 4)$ is \cup shaped

$$y = 0 \Rightarrow x = -1, 4$$

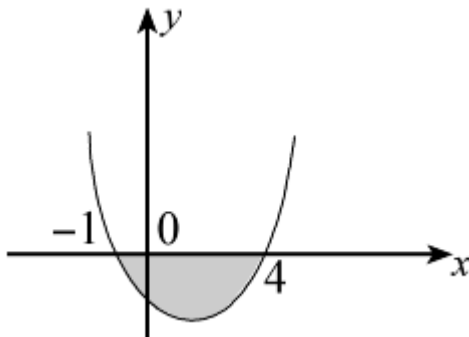

$$\begin{aligned} & \int_{-1}^4 (x + 1)(x - 4) \, dx \\ &= \int_{-1}^4 (x^2 - 3x - 4) \, dx \\ &= \left[\frac{x^3}{3} - \frac{3x^2}{2} - 4x \right]_{-1}^4 \\ &= \left(\frac{64}{3} - \frac{3}{2} \times 16 - 16 \right) - \left(-\frac{1}{3} - \frac{3}{2} + 4 \right) \\ &= \frac{64}{3} - 40 + \frac{11}{6} - 4 \\ &= -20 \frac{5}{6} \end{aligned}$$

$$\text{So area} = 20 \frac{5}{6}$$

Solutionbank C2

Edexcel Modular Mathematics for AS and A-Level

Integration

Exercise C, Question 3

Question:

Sketch the following and find the area of the finite region or regions bounded by the curve and the x -axis:

$$y = (x + 3)x(x - 3)$$

Solution:

$$y = (x + 3)x(x - 3)$$

$$y = 0 \Rightarrow x = -3, 0, 3$$

$$x \rightarrow \infty, y \rightarrow \infty$$

$$x \rightarrow -\infty, y \rightarrow -\infty$$

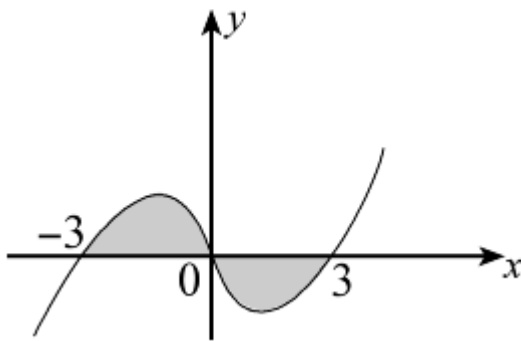

$$\int y dx = \int (x^3 - 9x) dx = \left[\frac{x^4}{4} - \frac{9}{2}x^2 \right]$$

$$\int_{-3}^0 y dx = \left(0 \right) - \left(\frac{81}{4} - \frac{9}{2} \times 9 \right) = + \frac{81}{4}$$

$$\int_0^3 y dx = \left(\frac{81}{4} - \frac{9}{2} \times 9 \right) - \left(0 \right) = - \frac{81}{4}$$

$$\text{So area} = \frac{81}{4} + \frac{81}{4} = \frac{81}{2} \text{ or } 40 \frac{1}{2}$$

Solutionbank C2

Edexcel Modular Mathematics for AS and A-Level

Integration

Exercise C, Question 4

Question:

Sketch the following and find the area of the finite region or regions bounded by the curves and the x -axis:

$$y = x^2 (x - 2)$$

Solution:

$$y = x^2 (x - 2)$$

$$y = 0 \Rightarrow x = 0 \text{ (twice), } 2$$

Turning point at $(0, 0)$

$$x \rightarrow \infty, y \rightarrow \infty$$

$$x \rightarrow -\infty, y \rightarrow -\infty$$

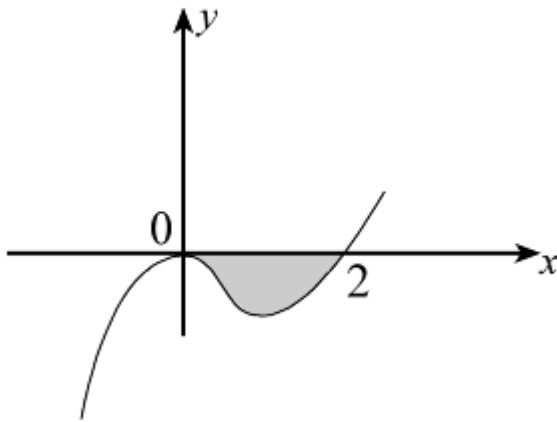

$$\text{Area} = - \int_0^2 x^2 (x - 2) \, dx$$

$$= - \int_0^2 (x^3 - 2x^2) \, dx$$

$$= - \left[\frac{x^4}{4} - \frac{2}{3}x^3 \right]_0^2$$

$$= - \left\{ \left(\frac{16}{4} - \frac{2}{3} \times 8 \right) - \left(0 \right) \right\}$$

$$= - \left(4 - \frac{16}{3} \right)$$

$$= \frac{4}{3} \text{ or } 1 \frac{1}{3}$$

Solutionbank C2

Edexcel Modular Mathematics for AS and A-Level

Integration

Exercise C, Question 5

Question:

Sketch the following and find the area of the finite region or regions bounded by the curve and the x -axis:

$$y = x(x - 2)(x - 5)$$

Solution:

$$y = x(x - 2)(x - 5)$$

$$y = 0 \Rightarrow x = 0, 2, 5$$

$$x \rightarrow \infty, y \rightarrow \infty$$

$$x \rightarrow -\infty, y \rightarrow -\infty$$

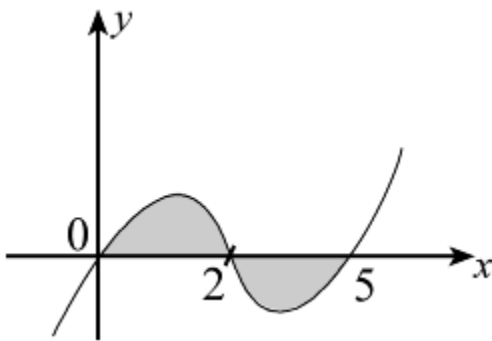

$$\int y dx = \int x(x^2 - 7x + 10) dx = \int (x^3 - 7x^2 + 10x) dx$$

$$\int y dx = \left[\frac{x^4}{4} - \frac{7}{3}x^3 + 5x^2 \right]$$

$$\int_0^2 y dx = \left(\frac{16}{4} - \frac{7}{3} \times 8 + 20 \right) - \left(0 \right) = 24 - \frac{56}{3} = 5 \frac{1}{3}$$

$$\int_2^5 y dx = \left(\frac{625}{4} - \frac{7}{3} \times 125 + 125 \right) - \left(5 \frac{1}{3} \right) = -15 \frac{3}{4}$$

$$\text{So area} = 5 \frac{1}{3} + 15 \frac{3}{4} = 21 \frac{1}{12}$$

Solutionbank C2

Edexcel Modular Mathematics for AS and A-Level

Integration

Exercise D, Question 1

Question:

The diagram shows part of the curve with equation $y = x^2 + 2$ and the line with equation $y = 6$. The line cuts the curve at the points A and B .

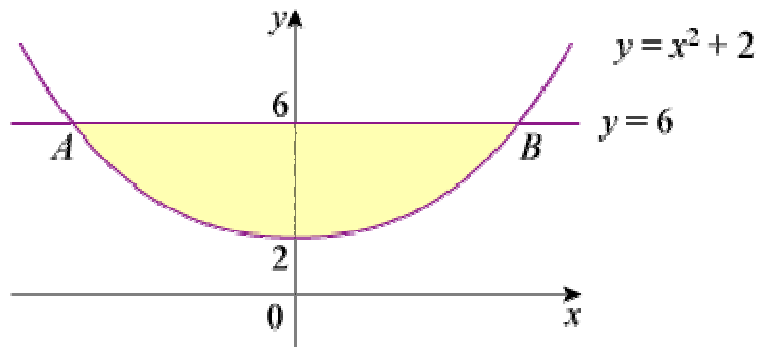

- Find the coordinates of the points A and B .
- Find the area of the finite region bounded by AB and the curve.

© Pearson Education Ltd 2008

Solutionbank C2

Edexcel Modular Mathematics for AS and A-Level

Integration

Exercise D, Question 2

Question:

The diagram shows the finite region, R , bounded by the curve with equation $y = 4x - x^2$ and the line $y = 3$. The line cuts the curve at the points A and B .

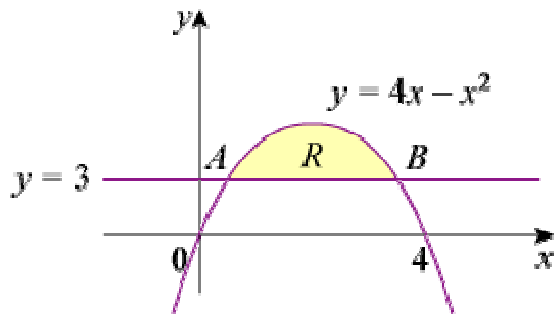

- (a) Find the coordinates of the points A and B .
- (b) Find the area of R .

Solution:

(a) A, B are given by

$$3 = 4x - x^2$$

$$x^2 - 4x + 3 = 0$$

$$(x - 3)(x - 1) = 0$$

$$x = 1, 3$$

So A is $(1, 3)$ and B is $(3, 3)$

$$(b) \text{ Area} = \int_1^3 [(4x - x^2) - 3] dx$$

$$= \int_1^3 (4x - x^2 - 3) dx$$

$$= \left[2x^2 - \frac{x^3}{3} - 3x \right]_1^3$$

$$= \left(18 - 9 - 9 \right) - \left(2 - \frac{1}{3} - 3 \right)$$

$$= 1 \frac{1}{3}$$

Solutionbank C2

Edexcel Modular Mathematics for AS and A-Level

Integration

Exercise D, Question 3

Question:

The diagram shows a sketch of part of the curve with equation $y = 9 - 3x - 5x^2 - x^3$ and the line with equation $y = 4 - 4x$. The line cuts the curve at the points $A(-1, 8)$ and $B(1, 0)$.

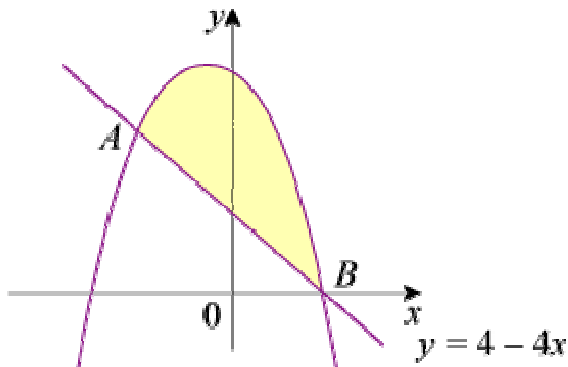

Find the area of the shaded region between AB and the curve.

Solution:

$$\begin{aligned}
 \text{Area} &= \int_{-1}^1 (\text{curve} - \text{line}) \, dx \\
 &= \int_{-1}^1 [9 - 3x - 5x^2 - x^3 - (4 - 4x)] \, dx \\
 &= \int_{-1}^1 (5 + x - 5x^2 - x^3) \, dx \\
 &= \left[5x + \frac{x^2}{2} - \frac{5}{3}x^3 - \frac{x^4}{4} \right]_{-1}^1 \\
 &= \left(5 + \frac{1}{2} - \frac{5}{3} - \frac{1}{4} \right) - \left(-5 + \frac{1}{2} + \frac{5}{3} - \frac{1}{4} \right) \\
 &= 10 - \frac{10}{3} \\
 &= \frac{20}{3} \text{ or } 6 \frac{2}{3}
 \end{aligned}$$

Solutionbank C2

Edexcel Modular Mathematics for AS and A-Level

Integration

Exercise D, Question 4

Question:

Find the area of the finite region bounded by the curve with equation $y = (1 - x)(x + 3)$ and the line $y = x + 3$.

Solution:

$y = (1 - x)(x + 3)$ is \cap shaped and crosses the x -axis at $(1, 0)$ and $(-3, 0)$
 $y = x + 3$ is a straight line passing through $(-3, 0)$ and $(0, 3)$

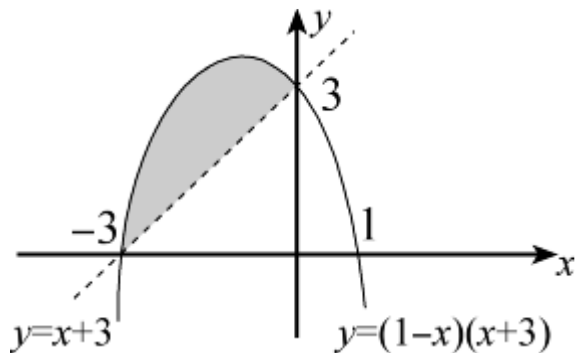

Intersections when

$$x + 3 = (1 - x)(x + 3)$$

$$0 = (x + 3)(1 - x - 1)$$

$$0 = -x(x + 3)$$

$$x = -3 \text{ or } 0$$

$$\text{Area} = \int_{-3}^0 [(1 - x)(x + 3) - (x + 3)] dx$$

$$= \int_{-3}^0 (-x^2 - 3x) dx$$

$$= \left[-\frac{x^3}{3} - \frac{3}{2}x^2 \right]_{-3}^0$$

$$= \left(0 \right) - \left(\frac{27}{3} - \frac{27}{2} \right)$$

$$= \frac{27}{6} \text{ or } \frac{9}{2} \text{ or } 4.5$$

Solutionbank C2

Edexcel Modular Mathematics for AS and A-Level

Integration

Exercise D, Question 5

Question:

The diagram shows the finite region, R , bounded by the curve with equation $y = x(4 + x)$, the line with equation $y = 12$ and the y -axis.

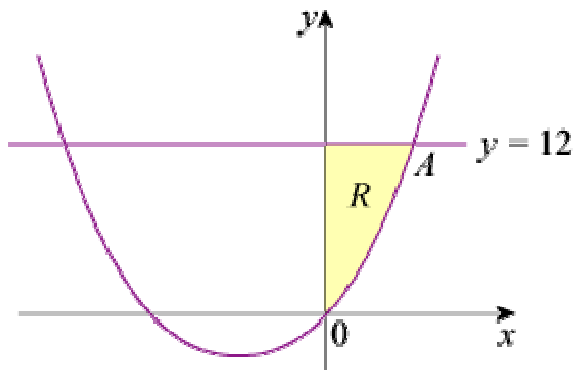

(a) Find the coordinate of the point A where the line meets the curve.

(b) Find the area of R .

Solution:

(a) A is given by
 $x(4 + x) = 12$
 $x^2 + 4x - 12 = 0$
 $(x + 6)(x - 2) = 0$
 $x = 2$ or -6
 So A is $(2, 12)$

(b) R is given by taking $\int_0^2 x(4 + x) dx$ away from a rectangle of area $12 \times 2 = 24$.

So area of R

$$= 24 - \int_0^2 (x^2 + 4x) dx$$

$$= 24 - \left[\frac{x^3}{3} + 2x^2 \right]_0^2$$

$$= 24 - \left\{ \left(\frac{8}{3} + 8 \right) - \left(0 \right) \right\}$$

$$= 24 - \frac{32}{3}$$

$$= \frac{40}{3} \text{ or } 13 \frac{1}{3}$$

Solutionbank C2

Edexcel Modular Mathematics for AS and A-Level

Integration

Exercise D, Question 6

Question:

The diagram shows a sketch of part of the curve with equation $y = x^2 + 1$ and the line with equation $y = 7 - x$. The finite region R_1 is bounded by the line and the curve. The finite region R_2 is below the curve and the line and is bounded by the positive x - and y -axes as shown in the diagram.

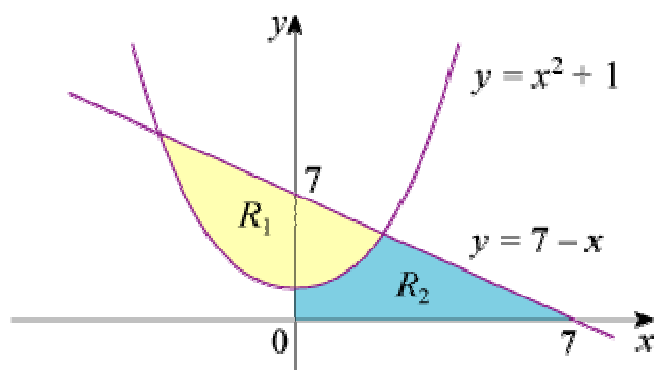

(a) Find the area of R_1 .

(b) Find the area of R_2 .

Solution:

(a) Intersections when

$$7 - x = x^2 + 1$$

$$0 = x^2 + x - 6$$

$$0 = (x + 3)(x - 2)$$

$$x = 2 \text{ or } -3$$

(a) Area of R_1 is given by $\int_{-3}^2 [7 - x - (x^2 + 1)] dx$

$$= \int_{-3}^2 (6 - x - x^2) dx$$

$$= \left[6x - \frac{x^2}{2} - \frac{x^3}{3} \right]_{-3}^2$$

$$= \left(12 - \frac{4}{2} - \frac{8}{3} \right) - \left(-18 - \frac{9}{2} + \frac{27}{3} \right)$$

$$= 20 \frac{5}{6}$$

(b) Area of R_2 is given by $\int_0^2 (x^2 + 1) dx$ + area of

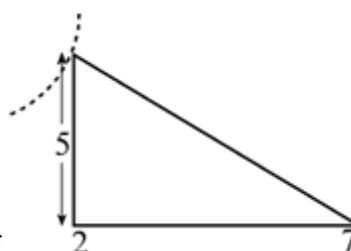

$$\begin{aligned} &= \left[\frac{x^3}{3} + x \right]_0^2 + \frac{1}{2} \times 5 \times 5 \\ &= \left(\frac{8}{3} + 2 \right) - \left(0 \right) + \frac{25}{2} \\ &= 17 \frac{1}{6} \end{aligned}$$

© Pearson Education Ltd 2008

Solutionbank C2

Edexcel Modular Mathematics for AS and A-Level

Integration

Exercise D, Question 7

Question:

The curve C has equation $y = x^{\frac{2}{3}} - \frac{2}{x^{\frac{1}{3}}} + 1$.

- (a) Verify that C crosses the x -axis at the point $(1, 0)$.
- (b) Show that the point $A(8, 4)$ also lies on C .
- (c) The point B is $(4, 0)$. Find the equation of the line through AB .
The finite region R is bounded by C , AB and the positive x -axis.
- (d) Find the area of R .

Solution:

(a) $x = 1, y = 1 - \frac{2}{1} + 1 = 0$

So $(1, 0)$ lies on C

(b) $x = 8, y = 8^{\frac{2}{3}} - \frac{2}{8^{\frac{1}{3}}} + 1 = 2^2 - \frac{2}{2} + 1 = 4$

So $(8, 4)$ lies on C

(c) A is $(8, 4)$ and B is $(4, 0)$

Gradient of line through AB is $\frac{4-0}{8-4} = 1$.

So equation is $y - 0 = x - 4$, i.e. $y = x - 4$

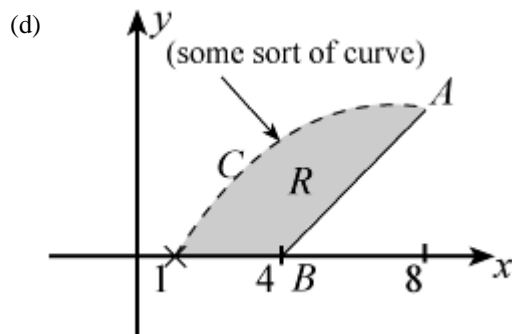

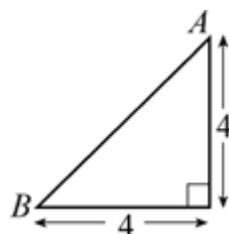

The area of R is given by \int_1^8 (curve) dx - area of

$$\begin{aligned}
 &= \int_1^8 \left(x^{\frac{2}{3}} - \frac{2}{x^{\frac{1}{3}}} + 1 \right) dx - \frac{1}{2} \times 4 \times 4 \\
 &= \left[\frac{3}{5} x^{\frac{5}{3}} - \frac{2x^{\frac{2}{3}}}{\frac{2}{3}} + x \right]_1^8 - 8 \\
 &= \left(\frac{3}{5} \times 32 - 3 \times 4 + 8 \right) - \left(\frac{3}{5} - 3 + 1 \right) - 8 \\
 &= \frac{93}{5} - 4 + 2 - 8 \\
 &= 8 \frac{3}{5}
 \end{aligned}$$

© Pearson Education Ltd 2008

Solutionbank C2

Edexcel Modular Mathematics for AS and A-Level

Integration

Exercise D, Question 8

Question:

The diagram shows part of a sketch of the curve with equation $y = \frac{2}{x^2} + x$.

The points A and B have x -coordinates $\frac{1}{2}$ and 2 respectively.

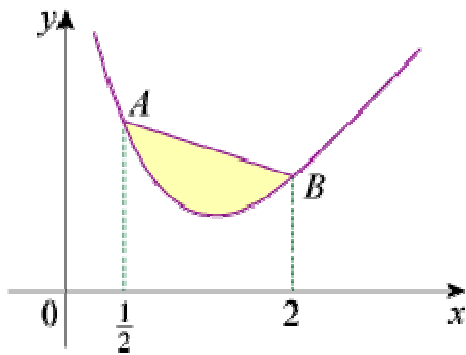

Find the area of the finite region between AB and the curve.

Solution:

$$\text{Area} = \int_{\frac{1}{2}}^2 \left[\text{line } AB - \left(\frac{2}{x^2} + x \right) \right] dx$$

$$A \text{ is } \left(\frac{1}{2}, 8\frac{1}{2} \right) \text{ and } B \text{ is } \left(2, 2\frac{1}{2} \right)$$

$$\text{Gradient} = -\frac{6}{1\frac{1}{2}} = -4$$

$$\text{So equation is } y - 2\frac{1}{2} = -4 \left(x - 2 \right), \text{ i.e. } y = 10\frac{1}{2} - 4x$$

$$\text{Area} = \int_{\frac{1}{2}}^2 \left(10\frac{1}{2} - 5x - 2x^{-2} \right) dx$$

$$= \left[\frac{21}{2}x - \frac{5}{2}x^2 - \frac{2x^{-1}}{-1} \right]_{\frac{1}{2}}^2$$

$$= \left[\frac{21}{2}x - \frac{5}{2}x^2 + \frac{2}{x} \right]_{\frac{1}{2}}^2$$

$$= \left(21 - 10 + 1 \right) - \left(\frac{21}{4} - \frac{5}{8} + 4 \right)$$

$$= 12 - 8 \frac{5}{8}$$

$$= 3 \frac{3}{8} \text{ or } 3.375 \text{ or } 3.38 \text{ (3 s.f.)}$$

© Pearson Education Ltd 2008

Solutionbank C2

Edexcel Modular Mathematics for AS and A-Level

Integration

Exercise D, Question 9

Question:

The diagram shows part of the curve with equation $y = 3\sqrt{x} - \sqrt{x^3} + 4$ and the line with equation $y = 4 - \frac{1}{2}x$.

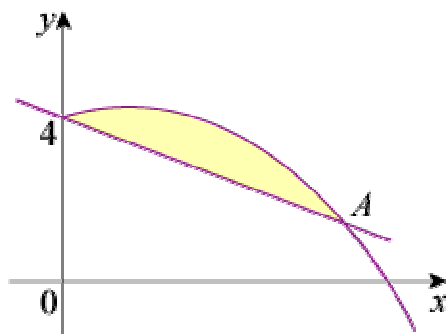

- (a) Verify that the line and the curve cross at the point $A(4, 2)$.
- (b) Find the area of the finite region bounded by the curve and the line.

Solution:

(a) $x = 4$ in line gives $y = 4 - \frac{1}{2} \times 4 = 2$

$x = 4$ in curve gives $y = 3 \times \sqrt{4} - \sqrt{64} + 4 = 6 - 8 + 4 = 2$

So $(4, 2)$ lies on line and curve.

(b) Area = $\int_0^4 \left[3x^{\frac{1}{2}} - x^{\frac{3}{2}} + 4 - \left(4 - \frac{1}{2}x \right) \right] dx$

= $\int_0^4 \left(3x^{\frac{1}{2}} - x^{\frac{3}{2}} + \frac{1}{2}x \right) dx$

= $\left[\frac{3x^{\frac{3}{2}}}{\frac{3}{2}} - \frac{x^{\frac{5}{2}}}{\frac{5}{2}} + \frac{x^2}{4} \right]_0^4$

= $\left[2x^{\frac{3}{2}} - \frac{2}{5}x^{\frac{5}{2}} + \frac{x^2}{4} \right]_0^4$

= $\left(2 \times 8 - \frac{2}{5} \times 32 + 4 \right) - \left(0 \right)$

= $20 - \frac{64}{5}$

= $\frac{36}{5}$ or 7.2

Solutionbank C2

Edexcel Modular Mathematics for AS and A-Level

Integration

Exercise D, Question 10

Question:

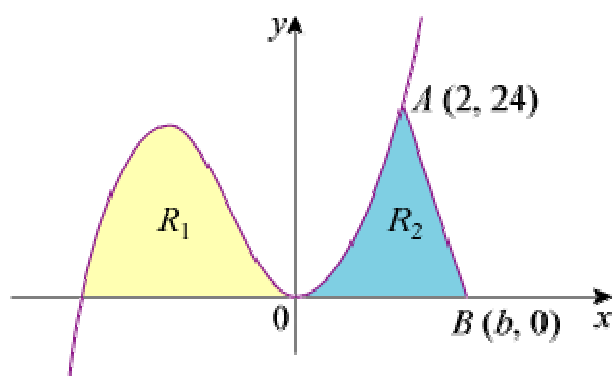

The sketch shows part of the curve with equation $y = x^2(x + 4)$. The finite region R_1 is bounded by the curve and the negative x -axis. The finite region R_2 is bounded by the curve, the positive x -axis and AB , where $A(2, 24)$ and $B(b, 0)$.

The area of $R_1 =$ the area of R_2 .

(a) Find the area of R_1 .

(b) Find the value of b .

Solution:

$$(a) y = x^2(x + 4)$$

$$y = 0 \Rightarrow x = 0 \text{ (twice), } -4$$

$$\text{Area of } R_1 \text{ is } \int_{-4}^0 (x^3 + 4x^2) dx$$

$$= \left[\frac{x^4}{4} + \frac{4}{3}x^3 \right]_{-4}^0$$

$$= \left(0 \right) - \left(\frac{4^4}{4} - \frac{4^4}{3} \right)$$

$$= \frac{4^4}{12} = \frac{4^3}{3} = \frac{64}{3} \text{ or } 21 \frac{1}{3}$$

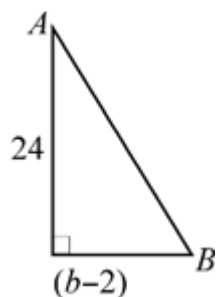

(b) Area of R_2 is $\int_0^2 (x^3 + 4x^2) dx +$ area of

$$\begin{aligned} &= \left[\frac{x^4}{4} + \frac{4}{3}x^3 \right]_0^2 + 12 \left(b - 2 \right) \\ &= \left(\frac{16}{4} + \frac{32}{3} \right) - \left(0 \right) + 12 \left(b - 2 \right) \\ &= 14 \frac{2}{3} + 12b - 24 \\ &= -9 \frac{1}{3} + 12b \end{aligned}$$

$$\text{Area of } R_2 = \text{area of } R_1 \Rightarrow -9 \frac{1}{3} + 12b = 21 \frac{1}{3}$$

$$\text{So } 12b = 30 \frac{2}{3} \Rightarrow b = 2 \frac{5}{9} \text{ or } 2.56 \text{ (3 s.f.)}$$

© Pearson Education Ltd 2008

Solutionbank C2

Edexcel Modular Mathematics for AS and A-Level

Integration

Exercise E, Question 1

Question:

Copy and complete the table below and use the trapezium rule to estimate $\int_1^3 \frac{1}{x^2+1} dx$:

x	1	1.5	2	2.5	3
$y = \frac{1}{x^2+1}$	0.5	0.308		0.138	

Solution:

$$x = 2, y = 0.2; x = 3, y = 0.1$$

$$h = 0.5$$

$$\text{So } A \approx \frac{1}{2} \times 0.5 \left[0.5 + 2 \left(0.308 + 0.2 + 0.138 \right) + 0.1 \right]$$

$$= \frac{1}{4} \left[1.892 \right]$$

$$= 0.473$$

© Pearson Education Ltd 2008

Solutionbank C2

Edexcel Modular Mathematics for AS and A-Level

Integration

Exercise E, Question 2

Question:

Use the table below to estimate $\int_1^{2.5} \sqrt{2x-1} \, dx$ with the trapezium rule:

x	1	1.25	1.5	1.75	2	2.25	2.5
$y = \sqrt{2x-1}$	1	1.225	1.414	1.581	1.732	1.871	2

Solution:

$$\begin{aligned}
 A &\approx \frac{1}{2} \times 0.25 \left[1 + 2 \left(1.225 + 1.414 + 1.581 + 1.732 + 1.871 \right) + 2 \right] \\
 &= \frac{1}{8} \left[18.646 \right] \\
 &= 2.33075 \\
 &= 2.33 \text{ (3 s.f.)}
 \end{aligned}$$

Solutionbank C2

Edexcel Modular Mathematics for AS and A-Level

Integration

Exercise E, Question 3

Question:

Copy and complete the table below and use it, together with the trapezium rule, to estimate $\int_0^2 \sqrt{x^3 + 1} \, dx$:

x	0	0.5	1	1.5	2
$y = \sqrt{x^3 + 1}$	1	1.061	1.414		

Solution:

$$x = 1.5, y = \sqrt{1.5^3 + 1} = 2.09165 \dots \text{ or } 2.092 \text{ (4 s.f.)}$$

$$x = 2, y = \sqrt{2^3 + 1} = 3$$

$$\int_0^2 \sqrt{x^3 + 1} \, dx$$

$$\approx \frac{1}{2} \times 0.5 \left[1 + 2 \left(1.061 + 1.414 + 2.092 \right) + 3 \right]$$

$$= \frac{1}{4} \left[13.134 \right]$$

$$= 3.2835$$

$$= 3.28 \text{ (3 s.f.)}$$

Solutionbank C2

Edexcel Modular Mathematics for AS and A-Level

Integration

Exercise E, Question 4

Question:

(a) Use the trapezium rule with 8 strips to estimate $\int_0^2 2^x dx$.

(b) With reference to a sketch of $y = 2^x$ explain whether your answer in part (a) is an underestimate or an overestimate of $\int_0^2 2^x dx$.

Solution:

$$h = 0.25$$

x	0	0.25	0.5	0.75	1.0	1.25	1.5	1.75	2.0
y	1	1.189	1.414	1.682	2	2.378	2.828	3.364	4

$$\begin{aligned} \int_0^2 2^x dx &\approx \frac{1}{2} \times 0.25 \left[1 + 2 \left(1.189 + 1.414 + 1.682 + 2 + 2.378 + 2.828 + 3.364 \right) + 4 \right] \\ &= \frac{1}{8} \left[34.71 \right] \\ &= 4.33875 \\ &= 4.34 \text{ (3 s.f.)} \end{aligned}$$

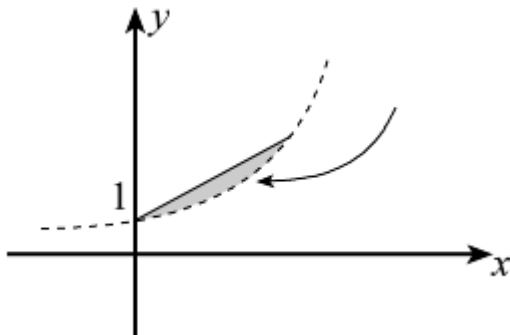

(b)

Curve bends beneath straight line of trapezium so trapezium rule will **overestimate**.

Solutionbank C2

Edexcel Modular Mathematics for AS and A-Level

Integration

Exercise E, Question 5

Question:

Use the trapezium rule with 6 strips to estimate $\int_0^3 \frac{1}{\sqrt{x^2+1}} dx$.

Solution:

$$h = 0.5$$

x	0	0.5	1	1.5	2	2.5	3
y	1	0.894	0.707	0.555	0.447	0.371	0.316

$$\begin{aligned}
 A &\approx \frac{1}{2} \times 0.5 \left[1 + 2 \left(0.894 + 0.707 + 0.555 + 0.447 + 0.371 \right) + 0.316 \right] \\
 &= \frac{1}{4} \left[7.264 \right] \\
 &= 1.816 \text{ or } 1.82 \text{ (3 s.f.)}
 \end{aligned}$$

© Pearson Education Ltd 2008

Solutionbank C2

Edexcel Modular Mathematics for AS and A-Level

Integration

Exercise E, Question 6

Question:

The diagram shows a sketch of part of the curve with equation $y = \frac{1}{x+2}$, $x > -2$.

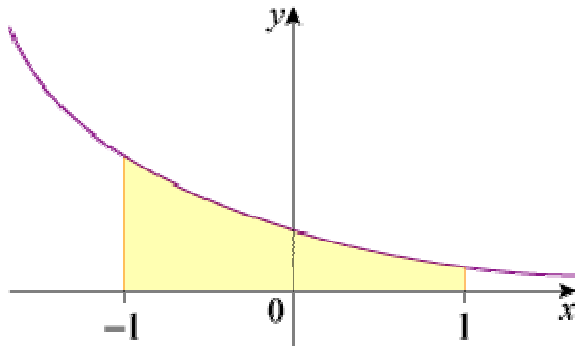

(a) Copy and complete the table below and use the trapezium rule to estimate the area bounded by the curve, the x -axis and the lines $x = -1$ and $x = 1$.

x	-1	-0.6	-0.2	0.2	0.6	1
$y = \frac{1}{x+2}$	1	0.714			0.385	0.333

(b) State, with a reason, whether your answer in part (a) is an overestimate or an underestimate.

Solution:

(a) $h = 0.4$

$$x = -0.2, y = \frac{1}{1.8} = 0.555 \dots = 0.556 \text{ (3 d.p.)}$$

$$x = 0.2, y = \frac{1}{2.2} = 0.4545 \dots = 0.455 \text{ (3 d.p.)}$$

$$\text{area} \approx \frac{1}{2} \times 0.4 \left[1 + 2 \left(0.714 + 0.556 + 0.455 + 0.385 \right) + 0.333 \right]$$

$$= 0.2 [5.553]$$

$$= 1.1106$$

$$= 1.11 \text{ (3 s.f.)}$$

(b) Curve bends down below the straight lines of the trapezia so trapezium rule will give an **overestimate**.

Solutionbank C2

Edexcel Modular Mathematics for AS and A-Level

Integration

Exercise E, Question 7

Question:

- (a) Sketch the curve with equation $y = x^3 + 1$, for $-2 < x < 2$.
- (b) Use the trapezium rule with 4 strips to estimate the value of $\int_{-1}^1 (x^3 + 1) dx$.
- (c) Use integration to find the exact value of $\int_{-1}^1 (x^3 + 1) dx$.
- (d) Comment on your answers to parts (b) and (c).

Solution:

- (a) $y = x^3 + 1$ is a vertical translation (+ 1) of $y = x^3$

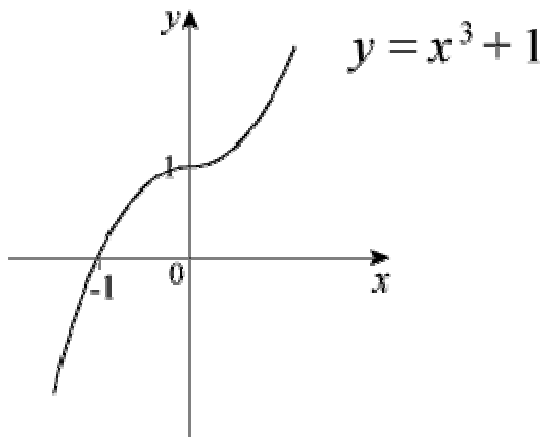

- (b) $h = 0.5$

$$\begin{array}{l} x \quad -1 \quad -0.5 \quad 0 \quad 0.5 \quad 1 \\ y \quad 0 \quad 0.875 \quad 1 \quad 1.125 \quad 2 \end{array}$$

$$\int_{-1}^1 (x^3 + 1) dx \approx \frac{1}{2} \times 0.5 \left[0 + 2 \left(0.875 + 1 + 1.125 \right) + 2 \right] = \frac{1}{4} \left[8 \right] = 2$$

$$(c) \int_{-1}^1 (x^3 + 1) dx = \left[\frac{x^4}{4} + x \right]_{-1}^1 = \left(\frac{1}{4} + 1 \right) - \left(\frac{1}{4} - 1 \right) = 2$$

- (d) Same. Curve has rotational symmetry of order 2 about (0, 1) and trapezia cut curve above and below symmetrically.

Solutionbank C2

Edexcel Modular Mathematics for AS and A-Level

Integration

Exercise E, Question 8

Question:

Use the trapezium rule with 4 strips to estimate $\int_0^2 \sqrt{3^x - 1} \, dx$.

Solution:

$$h = 0.5$$

$$x \quad 0 \quad 0.5 \quad 1 \quad 1.5 \quad 2$$

$$y \quad 0 \quad 0.856 \quad 1.414 \quad 2.048 \quad 2.828$$

$$\int_0^2 \sqrt{3^x - 1} \, dx \approx \frac{1}{2} \times 0.5 \left[0 + 2 \left(0.856 + 1.414 + 2.048 \right) + 2.828 \right]$$

$$= \frac{1}{4} \left[11.464 \right]$$

$$= 2.866$$

$$= 2.87 \text{ (3 s.f.)}$$

© Pearson Education Ltd 2008

Solutionbank C2

Edexcel Modular Mathematics for AS and A-Level

Integration

Exercise E, Question 9

Question:

The sketch shows part of the curve with equation $y = \frac{x}{x+1}$, $x \geq 0$.

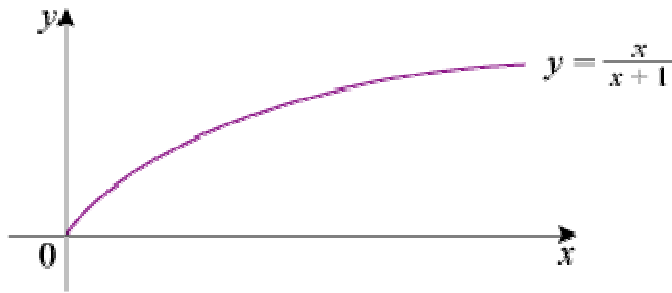

(a) Use the trapezium rule with 6 strips to estimate $\int_0^3 \frac{x}{x+1} dx$.

(b) With reference to the sketch state, with a reason, whether the answer in part (a) is an overestimate or an underestimate.

Solution:

(a) $h = 0.5$

x	0	0.5	1	1.5	2	2.5	3
y	0	0.333	0.5	0.6	0.667	0.714	0.75

$$\int_0^3 \frac{x}{x+1} dx \approx \frac{1}{2} \times 0.5 \left[0 + 2 \left(0.333 + 0.5 + 0.6 + 0.667 + 0.714 \right) + 0.75 \right]$$

$$= \frac{1}{4} \left[6.378 \right]$$

$$= 1.5945$$

$$= 1.59 \text{ (3 s.f.)}$$

(b) Curve bends outwards above straight lines of trapezia so trapezium rule is an **underestimate**.

Solutionbank C2

Edexcel Modular Mathematics for AS and A-Level

Integration

Exercise E, Question 10

Question:

(a) Use the trapezium rule with n strips to estimate $\int_0^2 \sqrt{x} \, dx$ in the cases (i) $n = 4$ (ii) $n = 6$.

(b) Compare your answers from part (a) with the exact value of the integral and calculate the percentage error in each case.

Solution:

(a) (i) $h = 0.5$

$$\begin{array}{l} x \quad 0 \quad 0.5 \quad 1 \quad 1.5 \quad 2 \\ y \quad 0 \quad 0.707 \quad 1 \quad 1.225 \quad 1.414 \end{array}$$

$$\int_0^2 \sqrt{x} \, dx \approx \frac{1}{2} \times 0.5 \left[0 + 2 \left(0.707 + 1 + 1.225 \right) + 1.414 \right] = \frac{1}{4} \left[7.278 \right] = 1.8195$$

(ii) $h = \frac{1}{3}$

$$\begin{array}{l} x \quad 0 \quad \frac{1}{3} \quad \frac{2}{3} \quad 1 \quad \frac{4}{3} \quad \frac{5}{3} \quad 2 \\ y \quad 0 \quad 0.577 \quad 0.816 \quad 1 \quad 1.155 \quad 1.291 \quad 1.414 \end{array}$$

$$\int_0^2 \sqrt{x} \, dx \approx \frac{1}{2} \times \frac{1}{3} \left[0 + 2 \left(0.577 + 0.816 + 1 + 1.155 + 1.291 \right) + 1.414 \right] = \frac{1}{6} \left[11.092 \right] = 1.8486$$

$$(b) \int_0^2 \sqrt{x} \, dx = \left[\frac{2}{3} x^{\frac{3}{2}} \right]_0^2 = \left(\frac{2}{3} \times 2 \sqrt{2} \right) - \left(0 \right) = \frac{4}{3} \sqrt{2} = 1.8856 \dots$$

$$(i) \% \text{ error} = \frac{100 \left(\frac{4}{3} \sqrt{2} - 1.8195 \right)}{\frac{4}{3} \sqrt{2}} = 3.51 \%$$

$$(ii) \% \text{ error} = \frac{100 \left(\frac{4}{3} \sqrt{2} - 1.8486 \right)}{\frac{4}{3} \sqrt{2}} = 1.96 \%$$

Solutionbank C2

Edexcel Modular Mathematics for AS and A-Level

Integration

Exercise F, Question 1

Question:

The diagram shows the curve with equation $y = 5 + 2x - x^2$ and the line with equation $y = 2$. The curve and the line intersect at the points A and B .

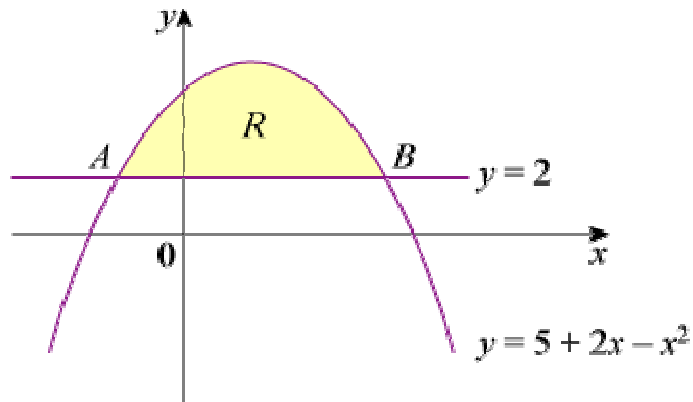

- (a) Find the x -coordinates of A and B .
- (b) The shaded region R is bounded by the curve and the line. Find the area of R .

[E]

Solution:

$$\begin{aligned}
 \text{(a) } 2 &= 5 + 2x - x^2 \\
 &\Rightarrow x^2 - 2x - 3 = 0 \\
 &\Rightarrow (x - 3)(x + 1) = 0 \\
 &\Rightarrow x = -1 \text{ (A), } 3 \text{ (B)}
 \end{aligned}$$

$$\begin{aligned}
 \text{(b) Area of } R &= \int_{-1}^3 (5 + 2x - x^2 - 2) \, dx \\
 &= \int_{-1}^3 (3 + 2x - x^2) \, dx \\
 &= \left[3x + x^2 - \frac{1}{3}x^3 \right]_{-1}^3 \\
 &= \left(9 + 9 - \frac{27}{3} \right) - \left(-3 + 1 + \frac{1}{3} \right) \\
 &= 9 + 2 - \frac{1}{3} \\
 &= 10 \frac{2}{3}
 \end{aligned}$$

Solutionbank C2

Edexcel Modular Mathematics for AS and A-Level

Integration

Exercise F, Question 2

Question:

The diagram shows part of the curve C with equation $y = x^3 - 9x^2 + px$, where p is a constant. The line l has equation $y + 2x = q$, where q is a constant. The point A is the intersection of C and l , and C has a minimum at the point B . The x -coordinates of A and B are 1 and 4 respectively.

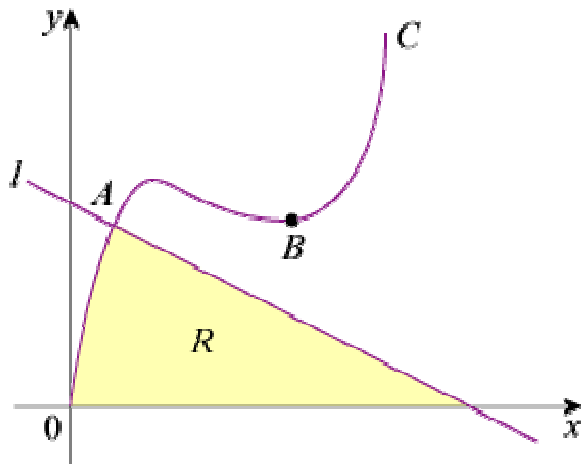

(a) Show that $p = 24$ and calculate the value of q .

(b) The shaded region R is bounded by C , l and the x -axis. Using calculus, showing all the steps in your working and using the values of p and q found in part (a), find the area of R .

[E]

Solution:

$$\begin{aligned} \text{(a) When } x = 1: q - 2x &= x^3 - 9x^2 + px \\ \Rightarrow q - 2 &= 1 - 9 + p \\ \Rightarrow q + 6 &= p \quad \textcircled{1} \end{aligned}$$

$$\text{When } x = 4: \frac{dy}{dx} = 3x^2 - 18x + p = 0$$

$$\Rightarrow 48 - 72 + p = 0$$

$$\Rightarrow p = 24$$

$$\text{Substitute into } \textcircled{1}: q = p - 6 = 18$$

$$\text{(b) Line is } y = 18 - 2x$$

So A is $(1, 16)$ and the line cuts the x -axis at $(9, 0)$

Area of R is given by

$$\int_0^1 (x^3 - 9x^2 + 24x) dx + \text{area of}$$

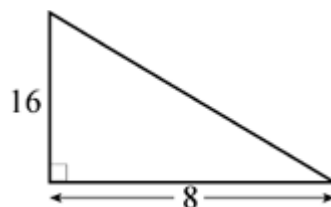

$$\begin{aligned} &= \left[\frac{x^4}{4} - \frac{9}{3}x^3 + \frac{24}{2}x^2 \right]_0^1 + \frac{1}{2} \times 8 \times 16 \\ &= \left[\frac{x^4}{4} - 3x^3 + 12x^2 \right]_0^1 + 64 \\ &= \left(\frac{1}{4} - 3 + 12 \right) - \left(0 \right) + 64 \\ &= 73 \frac{1}{4} \end{aligned}$$

© Pearson Education Ltd 2008

Solutionbank C2

Edexcel Modular Mathematics for AS and A-Level

Integration

Exercise F, Question 3

Question:

The diagram shows part of the curve C with equation $y = f(x)$, where $f(x) = 16x^{-\frac{1}{2}} + x^{\frac{3}{2}}$, $x > 0$.

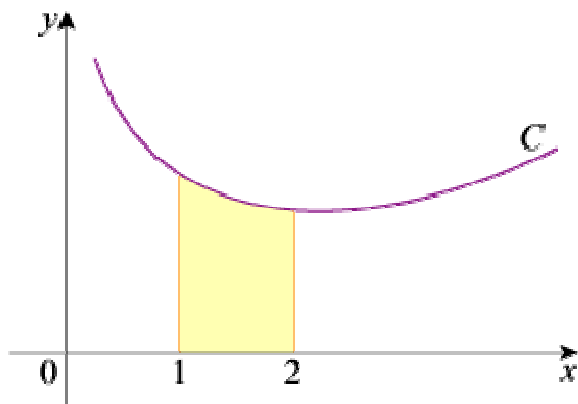

(a) Use calculus to find the x -coordinate of the minimum point of C , giving your answer in the form $k\sqrt{3}$, where k is an exact fraction.

The shaded region shown in the diagram is bounded by C , the x -axis and the lines with equations $x = 1$ and $x = 2$.

(b) Using integration and showing all your working, find the area of the shaded region, giving your answer in the form $a + b\sqrt{2}$, where a and b are exact fractions.

[E]

Solution:

$$(a) f'(x) = -8x^{-\frac{3}{2}} + \frac{3}{2}x^{\frac{1}{2}}$$

$$f'(x) = 0 \Rightarrow \frac{8}{x^{\frac{3}{2}}} = \frac{3}{2}x^{\frac{1}{2}} \text{ or } x^2 = \frac{16}{3}$$

$$(x \text{ must be positive}) \text{ So } x = \frac{4}{\sqrt{3}} \text{ or } \frac{4}{3}\sqrt{3}$$

$$(b) \text{ Area} = \int_1^2 \left(16x^{-\frac{1}{2}} + x^{\frac{3}{2}} \right) dx$$

$$= \left[\frac{16x^{\frac{1}{2}}}{\frac{1}{2}} + \frac{x^{\frac{5}{2}}}{\frac{5}{2}} \right]_1^2$$

$$= \left[32x^{\frac{1}{2}} + \frac{2}{5}x^{\frac{5}{2}} \right]_1^2$$

$$\begin{aligned} &= \left(32\sqrt{2} + \frac{2}{5} \times 2^2\sqrt{2} \right) - \left(32 + \frac{2}{5} \right) \\ &= \frac{168}{5}\sqrt{2} - \frac{162}{5} \end{aligned}$$

© Pearson Education Ltd 2008

Solutionbank C2

Edexcel Modular Mathematics for AS and A-Level

Integration

Exercise F, Question 4

Question:

(a) Find $\int \left(x^{\frac{1}{2}} - 4 \right) \left(x^{-\frac{1}{2}} - 1 \right) dx$.

(b) Use your answer to part (a) to evaluate

$$\int_1^4 \left(x^{\frac{1}{2}} - 4 \right) \left(x^{-\frac{1}{2}} - 1 \right) dx.$$

giving your answer as an exact fraction.

[E]

Solution:

$$(a) \left(x^{\frac{1}{2}} - 4 \right) \left(x^{-\frac{1}{2}} - 1 \right) = 1 - 4x^{-\frac{1}{2}} - x^{\frac{1}{2}} + 4 = 5 - 4x^{-\frac{1}{2}} - x^{\frac{1}{2}}$$

$$\int \left(x^{\frac{1}{2}} - 4 \right) \left(x^{-\frac{1}{2}} - 1 \right) dx = 5x - \frac{4x^{\frac{1}{2}}}{\frac{1}{2}} - \frac{x^{\frac{3}{2}}}{\frac{3}{2}} + c = 5x - 8x^{\frac{1}{2}} - \frac{2}{3}x^{\frac{3}{2}} + c$$

$$\begin{aligned} (b) \int_1^4 \left(x^{\frac{1}{2}} - 4 \right) \left(x^{-\frac{1}{2}} - 1 \right) dx &= \left[5x - 8x^{\frac{1}{2}} - \frac{2}{3}x^{\frac{3}{2}} \right]_1^4 \\ &= \left(20 - 8 \times 2 - \frac{2}{3} \times 2^3 \right) - \left(5 - 8 - \frac{2}{3} \right) \\ &= 4 - \frac{16}{3} + 3 + \frac{2}{3} \\ &= 7 - \frac{14}{3} \\ &= \frac{7}{3} \text{ or } 2\frac{1}{3} \end{aligned}$$

Solutionbank C2

Edexcel Modular Mathematics for AS and A-Level

Integration

Exercise F, Question 5

Question:

The diagram shows part of the curve with equation $y = x^3 - 6x^2 + 9x$. The curve touches the x -axis at A and has a maximum turning point at B .

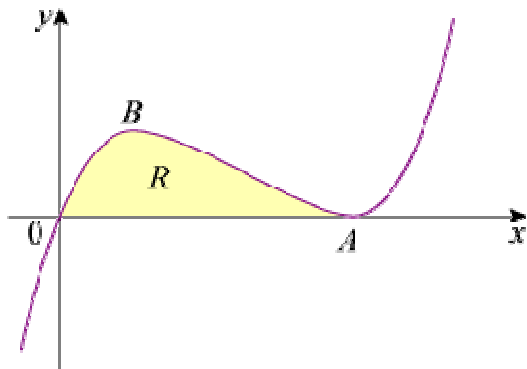

- (a) Show that the equation of the curve may be written as $y = x(x-3)^2$, and hence write down the coordinates of A .
- (b) Find the coordinates of B .
- (c) The shaded region R is bounded by the curve and the x -axis. Find the area of R .

[E]

Solution:

(a) $(x-3)^2 = x^2 - 6x + 9$
 So $x(x-3)^2 = x^3 - 6x^2 + 9x$
 $y = 0 \Rightarrow x = 0$ [i.e. $(0, 0)$] or 3 (twice)
 So A is $(3, 0)$

(b) $\frac{dy}{dx} = 0 \Rightarrow 0 = 3x^2 - 12x + 9$
 $\Rightarrow 0 = 3(x^2 - 4x + 3)$
 $\Rightarrow 0 = 3(x-3)(x-1)$
 $\Rightarrow x = 1$ or 3
 $x = 3$ at A , the minimum, so B is $(1, 4)$

(c) Area of $R = \int_0^3 (x^3 - 6x^2 + 9x) dx$
 $= \left[\frac{1}{4}x^4 - 2x^3 + \frac{9}{2}x^2 \right]_0^3$
 $= \left(\frac{81}{4} - 2 \times 27 + \frac{9}{2} \times 9 \right) - \left(0 \right)$
 $= 6 \frac{3}{4}$

Solutionbank C2

Edexcel Modular Mathematics for AS and A-Level

Integration

Exercise F, Question 6

Question:

Given that $y^{\frac{1}{2}} = x^{\frac{1}{3}} + 3$:

(a) Show that $y = x^{\frac{2}{3}} + Ax^{\frac{1}{3}} + B$, where A and B are constants to be found.

(b) Hence find $\int y \, dx$.

(c) Using your answer from part (b) determine the exact value of $\int_1^8 y \, dx$.

[E]

Solution:

$$(a) y = \left(x^{\frac{1}{3}} + 3 \right)^2 = x^{\frac{2}{3}} + 6x^{\frac{1}{3}} + 9 \quad (A = 6, B = 9)$$

$$(b) \int y \, dx = \left[\begin{array}{l} \frac{x^{\frac{5}{3}}}{\frac{5}{3}} + \frac{6x^{\frac{4}{3}}}{\frac{4}{3}} + 9x + c \\ \frac{5}{3} \quad \frac{4}{3} \end{array} \right]$$

$$= \frac{3}{5}x^{\frac{5}{3}} + \frac{9}{2}x^{\frac{4}{3}} + 9x + c$$

$$(c) \int_1^8 y \, dx = \left[\frac{3}{5}x^{\frac{5}{3}} + \frac{9}{2}x^{\frac{4}{3}} + 9x \right]_1^8$$

$$= \left(\frac{3}{5} \times 32 + \frac{9}{2} \times 16 + 72 \right) - \left(\frac{3}{5} + \frac{9}{2} + 9 \right)$$

$$= \frac{93}{5} + 135 - \frac{9}{2}$$

$$= 149 \frac{1}{10} \text{ or } 149.1$$

Solutionbank C2

Edexcel Modular Mathematics for AS and A-Level

Integration

Exercise F, Question 7

Question:

Considering the function $y = 3x^{\frac{1}{2}} - 4x^{-\frac{1}{2}}$, $x > 0$:

(a) Find $\frac{dy}{dx}$.

(b) Find $\int y \, dx$.

(c) Hence show that $\int_1^3 y \, dx = A + B\sqrt{3}$, where A and B are integers to be found.

[E]

Solution:

(a) $y = 3x^{\frac{1}{2}} - 4x^{-\frac{1}{2}}$

$$\frac{dy}{dx} = \frac{3}{2}x^{-\frac{1}{2}} + \frac{1}{2} \times 4x^{-\frac{3}{2}}$$

$$\frac{dy}{dx} = \frac{3}{2}x^{-\frac{1}{2}} + 2x^{-\frac{3}{2}}$$

(b) $\int y \, dx = \int \left(3x^{\frac{1}{2}} - 4x^{-\frac{1}{2}} \right) dx$

$$= \frac{3x^{\frac{3}{2}}}{\frac{3}{2}} - \frac{4x^{\frac{1}{2}}}{\frac{1}{2}} + c$$

$$= 2x^{\frac{3}{2}} - 8x^{\frac{1}{2}} + c$$

(c) $\int_1^3 y \, dx = \left[2x^{\frac{3}{2}} - 8x^{\frac{1}{2}} \right]_1^3$

$$= (2 \times 3\sqrt{3} - 8\sqrt{3}) - (2 - 8)$$

$$= -2\sqrt{3} + 6$$

$$= 6 - 2\sqrt{3}$$

Solutionbank C2

Edexcel Modular Mathematics for AS and A-Level

Integration

Exercise F, Question 8

Question:

The diagram shows a sketch of the curve with equation $y = 2x - x^2$ and the line ON which is the normal to the curve at the origin O .

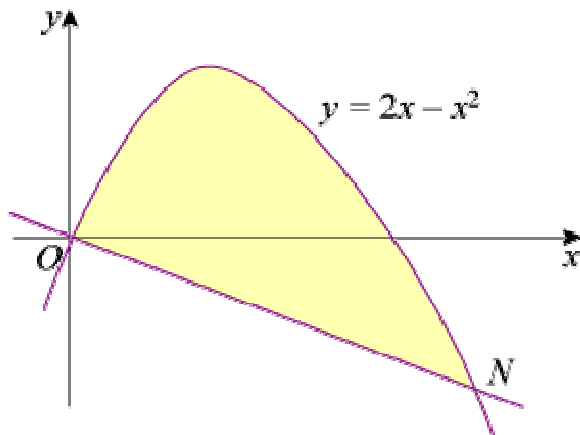

(a) Find an equation of ON .

(b) Show that the x -coordinate of the point N is $2\frac{1}{2}$ and determine its y -coordinate.

(c) The shaded region shown is bounded by the curve and the line ON . Without using a calculator, determine the area of the shaded region.

Solution:

$$(a) y = 2x - x^2$$

$$\frac{dy}{dx} = 2 - 2x$$

Gradient of tangent at $(0, 0)$ is 2.

$$\text{Gradient of } ON = -\frac{1}{2}$$

So equation of ON is $y = -\frac{1}{2}x$ or $2y + x = 0$

(b) N is point of intersection of ON and the curve, so

$$-\frac{1}{2}x = 2x - x^2$$

$$2x^2 - 5x = 0$$

$$x(2x - 5) = 0$$

$$x = 0, \frac{5}{2}$$

$$\text{So } N \text{ is } \left(2\frac{1}{2}, -1\frac{1}{4} \right)$$

$$\begin{aligned} \text{(c) Area} &= \int_0^{2\frac{1}{2}} (\text{curve} - \text{line}) \, dx \\ &= \int_0^{2\frac{1}{2}} \left[2x - x^2 - \left(-\frac{1}{2}x \right) \right] dx \\ &= \int_0^{2\frac{1}{2}} \left(\frac{5}{2}x - x^2 \right) dx \\ &= \left[\frac{5}{4}x^2 - \frac{x^3}{3} \right]_0^{2\frac{1}{2}} \\ &= \left(\frac{31.25}{4} - \frac{15.625}{3} \right) - \left(0 \right) \\ &= \frac{125}{48} \end{aligned}$$

© Pearson Education Ltd 2008

Solutionbank C2

Edexcel Modular Mathematics for AS and A-Level

Integration

Exercise F, Question 9

Question:

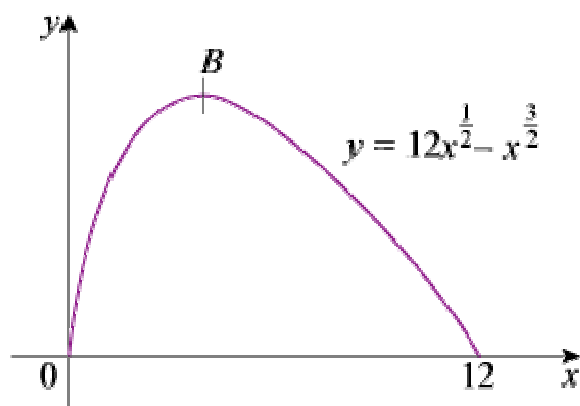

The diagram shows a sketch of the curve with equation

$$y = 12x^{\frac{1}{2}} - x^{\frac{3}{2}} \text{ for } 0 \leq x \leq 12.$$

(a) Show that $\frac{dy}{dx} = \frac{3}{2}x^{-\frac{1}{2}}(4 - x)$.

(b) At the point B on the curve the tangent to the curve is parallel to the x -axis. Find the coordinates of the point B .

(c) Find, to 3 significant figures, the area of the finite region bounded by the curve and the x -axis.

[E]

Solution:

(a) $y = 12x^{\frac{1}{2}} - x^{\frac{3}{2}}$

$$\frac{dy}{dx} = 6x^{-\frac{1}{2}} - \frac{3}{2}x^{\frac{1}{2}} = \frac{3}{2}x^{-\frac{1}{2}}(4 - x)$$

(b) $\frac{dy}{dx} = 0 \Rightarrow x = 4, y = 12 \times 2 - 2^3 = 16$

So B is $(4, 16)$

(c) Area = $\int_0^{12} \left(12x^{\frac{1}{2}} - x^{\frac{3}{2}} \right) dx$

$$= \left[\frac{12x^{\frac{3}{2}}}{\frac{3}{2}} - \frac{x^{\frac{5}{2}}}{\frac{5}{2}} \right]_0^{12} = \left[\frac{3}{2} \cdot 12x^{\frac{3}{2}} - \frac{2}{5}x^{\frac{5}{2}} \right]_0^{12}$$

$$\begin{aligned} &= \left[8x^{\frac{3}{2}} - \frac{2}{5}x^{\frac{5}{2}} \right]_0^{12} \\ &= \left(8 \times \sqrt{12^3} - \frac{2}{5}\sqrt{12^5} \right) - \left(0 \right) \\ &= 133.0215 \dots \\ &= 133 \text{ (3 s.f.)} \end{aligned}$$

© Pearson Education Ltd 2008

Solutionbank C2

Edexcel Modular Mathematics for AS and A-Level

Integration

Exercise F, Question 10

Question:

The diagram shows the curve C with equation $y = x(8 - x)$ and the line with equation $y = 12$ which meet at the points L and M .

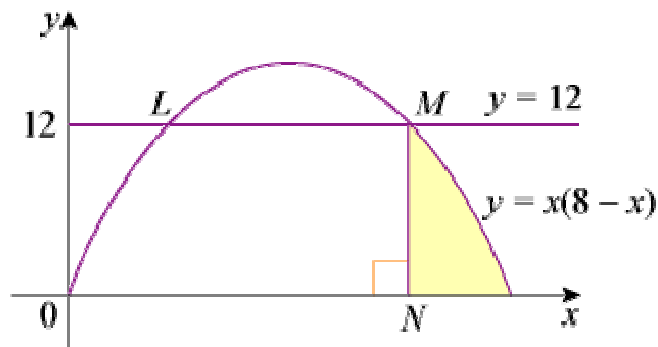

(a) Determine the coordinates of the point M .

(b) Given that N is the foot of the perpendicular from M on to the x -axis, calculate the area of the shaded region which is bounded by NM , the curve C and the x -axis.

[E]

Solution:

$$\begin{aligned}
 \text{(a) } x(8 - x) &= 12 \\
 \Rightarrow 8x - x^2 &= 12 \\
 \Rightarrow 0 &= x^2 - 8x + 12 \\
 \Rightarrow 0 &= (x - 6)(x - 2) \\
 \Rightarrow x &= 2 \text{ or } 6
 \end{aligned}$$

M is on the right of L , so M is $(6, 12)$

$$\begin{aligned}
 \text{(b) Area} &= \int_6^8 (8x - x^2) \, dx \\
 &= \left[4x^2 - \frac{x^3}{3} \right]_6^8 \\
 &= \left(4 \times 64 - \frac{512}{3} \right) - \left(4 \times 36 - \frac{216}{3} \right) \\
 &= 256 - 170 \frac{2}{3} - 144 + 72 \\
 &= 13 \frac{1}{3}
 \end{aligned}$$

Solutionbank C2

Edexcel Modular Mathematics for AS and A-Level

Integration

Exercise F, Question 11

Question:

The diagram shows the line $y = x - 1$ meeting the curve with equation $y = (x - 1)(x - 5)$ at A and C . The curve meets the x -axis at A and B .

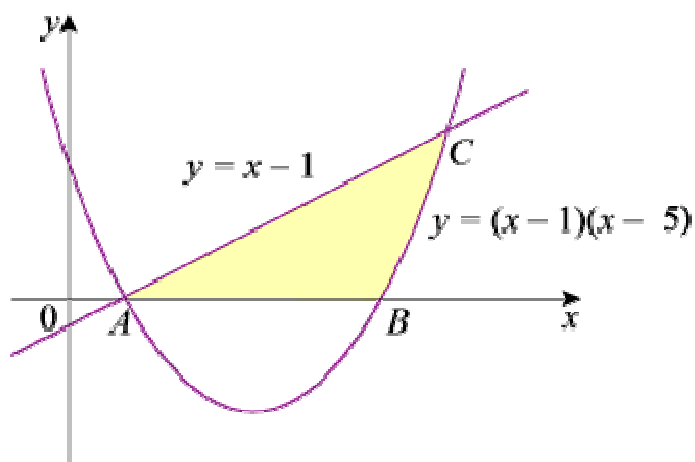

- (a) Write down the coordinates of A and B and find the coordinates of C .
- (b) Find the area of the shaded region bounded by the line, the curve and the x -axis.

Solution:

(a) A is $(1, 0)$, B is $(5, 0)$

$$x - 1 = (x - 1)(x - 5)$$

$$\Rightarrow 0 = (x - 1)(x - 5 - 1)$$

$$\Rightarrow 0 = (x - 1)(x - 6)$$

$$\Rightarrow x = 1, 6$$

So C is $(6, 5)$

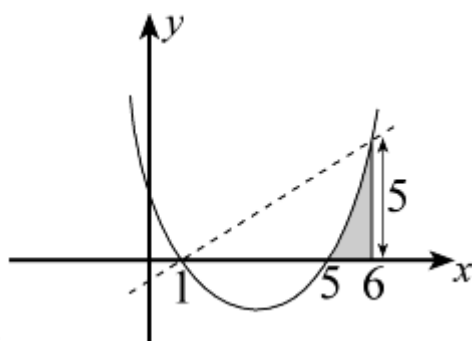

(b)

$$\text{Shaded region is } \int_5^6 (x - 1)(x - 5) dx = \int_5^6 (x^2 - 6x + 5) dx$$

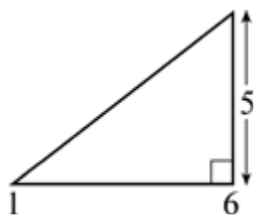

Required area = area of $\int_1^6 (x^2 - 6x + 5) dx$

$$= \frac{1}{2} \times 5 \times 5 - \left[\frac{x^3}{3} - 3x^2 + 5x \right]_1^6$$

$$= 12 \frac{1}{2} - \left[\left(\frac{216}{3} - 3 \times 36 + 30 \right) - \left(\frac{125}{3} - 75 + 25 \right) \right]$$

$$= 12 \frac{1}{2} + 6 - 50 + 41 \frac{2}{3}$$

$$= 10 \frac{1}{6}$$

© Pearson Education Ltd 2008

Solutionbank C2

Edexcel Modular Mathematics for AS and A-Level

Integration

Exercise F, Question 12

Question:

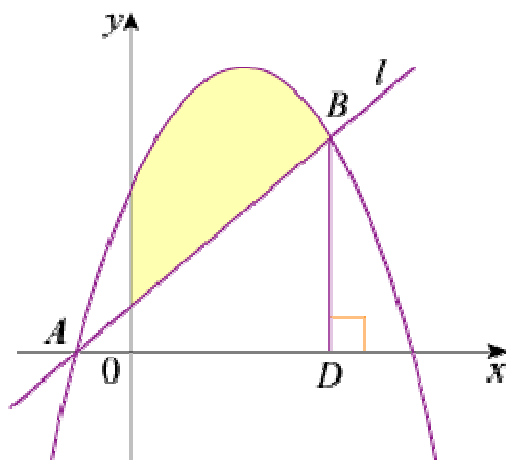

A and B are two points which lie on the curve C , with equation $y = -x^2 + 5x + 6$. The diagram shows C and the line l passing through A and B .

(a) Calculate the gradient of C at the point where $x = 2$.

The line l passes through the point with coordinates $(2, 3)$ and is parallel to the tangent to C at the point where $x = 2$.

(b) Find an equation of l .

(c) Find the coordinates of A and B .

The point D is the foot of the perpendicular from B on to the x -axis.

(d) Find the area of the region bounded by C , the x -axis, the y -axis and BD .

(e) Hence find the area of the shaded region.

[E]

Solution:

$$(a) \frac{dy}{dx} = -2x + 5$$

When $x = 2$ gradient of C is $-4 + 5 = 1$

(b) Equation of l is $y - 3 = 1(x - 2)$ i.e. $y = x + 1$

(c) A is $(-1, 0)$

B is given by

$$x + 1 = -x^2 + 5x + 6$$

$$x^2 - 4x - 5 = 0$$

$$(x - 5)(x + 1) = 0$$

$$x = -1 \text{ or } 5$$

So B is $(5, 6)$

$$(d) \text{Area} = \int_0^5 (-x^2 + 5x + 6) dx$$

$$\begin{aligned}
 &= \left[-\frac{x^3}{3} + \frac{5x^2}{2} + 6x \right]_0^5 \\
 &= \left(-\frac{125}{3} + \frac{125}{2} + 30 \right) - \left(0 \right) \\
 &= \frac{125}{6} + 30 \\
 &= 50 \frac{5}{6}
 \end{aligned}$$

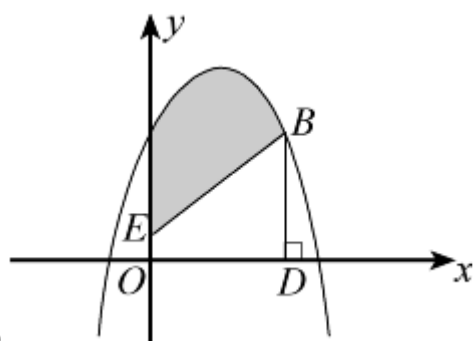

(e)

Required area is (d) – trapezium $OEBD$

$$\text{Area of trapezium} = \frac{1}{2} \times 5 \times \left(1 + 6 \right) = \frac{35}{2} = 17 \frac{1}{2}$$

$$\text{Shaded region} = 50 \frac{5}{6} - 17 \frac{1}{2} = 33 \frac{1}{3}$$

© Pearson Education Ltd 2008

Solutionbank C2

Edexcel Modular Mathematics for AS and A-Level

Integration

Exercise F, Question 13

Question:

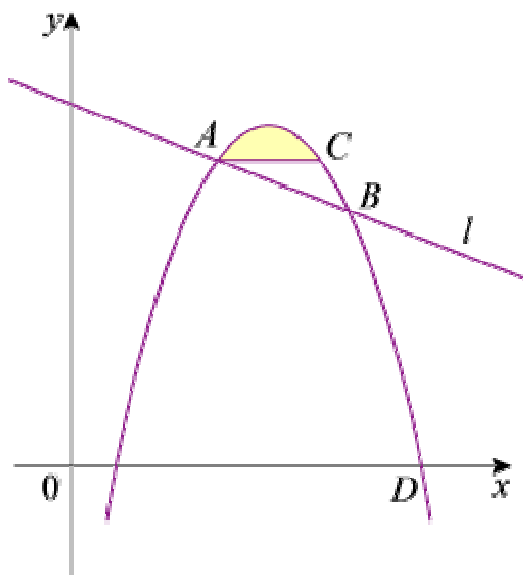

The diagram shows part of the curve with equation $y = p + 10x - x^2$, where p is a constant, and part of the line l with equation $y = qx + 25$, where q is a constant. The line l cuts the curve at the points A and B . The x -coordinates of A and B are 4 and 8 respectively. The line through A parallel to the x -axis intersects the curve again at the point C .

- (a) Show that $p = -7$ and calculate the value of q .
- (b) Calculate the coordinates of C .
- (c) The shaded region in the diagram is bounded by the curve and the line AC . Using algebraic integration and showing all your working, calculate the area of the shaded region.

[E]

Solution:

(a) Using A which lies on line and curve: $4q + 25 = p + 40 - 16$

i.e. $4q = p - 1$ ①

Using B which lies on line and curve: $8q + 25 = p + 80 - 64$

i.e. $8q = p - 9$ ②

Solving ② - ① $\Rightarrow 4q = -8 \Rightarrow q = -2$

Substitute into ① $\Rightarrow p = 1 + 4q = -7$

(b) At A , $y = 4q + 25 = 17$

So C is given by

$$17 = -7 + 10x - x^2$$

$$x^2 - 10x + 24 = 0$$

$$(x - 6)(x - 4) = 0$$

$$x = 4, 6$$

So C is $(6, 17)$

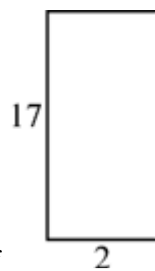

(c) Area = $\int_4^6 (-7 + 10x - x^2) dx$ - area of

$$\begin{aligned} &= \left[-7x + 5x^2 - \frac{1}{3}x^3 \right]_4^6 - 34 \\ &= \left(-42 + 180 - 72 \right) - \left(-28 + 80 - \frac{64}{3} \right) - 34 \\ &= \frac{4}{3} \text{ or } 1 \frac{1}{3} \end{aligned}$$

© Pearson Education Ltd 2008

Solutionbank C2

Edexcel Modular Mathematics for AS and A-Level

Practice paper

Exercise 1, Question 1

Question:

The sector AOB is removed from a circle of radius 5 cm.

The $\angle AOB$ is 1.4 radians and $OA = OB$.

(a) Find the perimeter of the sector AOB . (3)

(b) Find the area of sector AOB . (2)

Solution:

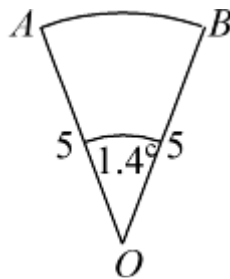

(a)

$$\text{Arc length} = r\theta = 5 \times 1.4 = 7 \text{ cm}$$

$$\text{Perimeter} = 10 + \text{Arc} = 17 \text{ cm}$$

$$(b) \text{ Sector area} = \frac{1}{2}r^2\theta = \frac{1}{2} \times 5^2 \times 1.4 = 17.5 \text{ cm}^2$$

Solutionbank C2

Edexcel Modular Mathematics for AS and A-Level

Practice paper Exercise 1, Question 2

Question:

Given that $\log_2 x = p$:

- (a) Find $\log_2 (8x^2)$ in terms of p . (4)
- (b) Given also that $p = 5$, find the value of x . (2)

Solution:

(a) $\log_2 x = p$

$$\log_2 (8x^2) = \log_2 8 + \log_2 x^2 = 3 + 2 \log_2 x = 3 + 2p$$

(b) $\log_2 x = 5 \Rightarrow x = 2^5 \Rightarrow x = 32$

© Pearson Education Ltd 2008

Solutionbank C2

Edexcel Modular Mathematics for AS and A-Level

Practice paper Exercise 1, Question 3

Question:

- (a) Find the value of the constant a so that $(x - 3)$ is a factor of $x^3 - ax - 6$. (3)
- (b) Using this value of a , factorise $x^3 - ax - 6$ completely. (4)

Solution:

(a) Let $f(x) = x^3 - ax - 6$
If $(x - 3)$ is a factor then $f(3) = 0$
i.e. $0 = 27 - 3a - 6$
So $3a = 21 \Rightarrow a = 7$

(b) $x^3 - 7x - 6$ has $(x - 3)$ as a factor, so
 $x^3 - 7x - 6 = (x - 3)(x^2 + 3x + 2) = (x - 3)(x + 2)(x + 1)$

© Pearson Education Ltd 2008

Solutionbank C2

Edexcel Modular Mathematics for AS and A-Level

Practice paper Exercise 1, Question 4

Question:

(a) Find the coefficient of x^{11} and the coefficient of x^{12} in the binomial expansion of $(2 + x)^{15}$. (4)

The coefficient of x^{11} and the coefficient of x^{12} in the binomial expansion of $(2 + kx)^{15}$ are equal.

(b) Find the value of the constant k . (3)

Solution:

$$(a) (2 + x)^{15} = \dots \binom{15}{11} 2^4 x^{11} + \binom{15}{12} 2^3 x^{12} + \dots$$

$$\text{Coefficient of } x^{11} = \binom{15}{11} \times 16 = 1365 \times 16 = 21\,840$$

$$\text{Coefficient of } x^{12} = \binom{15}{12} \times 8 = 455 \times 8 = 3640$$

$$(b) 21\,840k^{11} = 3640k^{12}$$

$$\text{So } k = \frac{21\,840}{3640}$$

$$\text{i.e. } k = 6$$

Solutionbank C2

Edexcel Modular Mathematics for AS and A-Level

Practice paper Exercise 1, Question 5

Question:

(a) Prove that:

$$\frac{\cos^2 \theta}{\sin \theta + \sin^2 \theta} \equiv \frac{1 - \sin \theta}{\sin \theta}, 0 < \theta < 180^\circ. \quad (4)$$

(b) Hence, or otherwise, solve the following equation for $0 < \theta < 180^\circ$:

$$\frac{\cos^2 \theta}{\sin \theta + \sin^2 \theta} = 2$$

Give your answers to the nearest degree. (4)

Solution:

$$\begin{aligned} \text{(a) LHS} &= \frac{\cos^2 \theta}{\sin \theta + \sin^2 \theta} \\ &= \frac{1 - \sin^2 \theta}{\sin \theta + \sin^2 \theta} \text{ (using } \sin^2 \theta + \cos^2 \theta \equiv 1) \\ &= \frac{(1 - \sin \theta)(1 + \sin \theta)}{\sin \theta(1 + \sin \theta)} \text{ (factorising)} \\ &= \frac{1 - \sin \theta}{\sin \theta} \text{ (cancelling } [1 + \sin \theta] \text{)} \\ &= \text{RHS} \end{aligned}$$

$$\begin{aligned} \text{(b) } 2 &= \frac{\cos^2 \theta}{\sin \theta + \sin^2 \theta} \\ \Rightarrow 2 &= \frac{1 - \sin \theta}{\sin \theta} \\ \Rightarrow 2 \sin \theta &= 1 - \sin \theta \text{ (can multiply by } \sin \theta \text{ } \because 0 < \theta < 180) \\ \Rightarrow 3 \sin \theta &= 1 \\ \Rightarrow \sin \theta &= \frac{1}{3} \end{aligned}$$

So $\theta = 19.47 \dots^\circ, 160.5 \dots^\circ = 19^\circ, 161^\circ$ (to nearest degree)

Solutionbank C2

Edexcel Modular Mathematics for AS and A-Level

Practice paper

Exercise 1, Question 6

Question:

- (a) Show that the centre of the circle with equation $x^2 + y^2 = 6x + 8y$ is $(3, 4)$ and find the radius of the circle. (5)
- (b) Find the exact length of the tangents from the point $(10, 0)$ to the circle. (4)

Solution:

$$\begin{aligned} \text{(a)} \quad x^2 - 6x + y^2 - 8y &= 0 \\ \Rightarrow (x - 3)^2 + (y - 4)^2 &= 9 + 16 \\ \text{i.e. } (x - 3)^2 + (y - 4)^2 &= 5^2 \\ \text{Centre } (3, 4), \text{ radius } &5 \end{aligned}$$

$$\text{(b) Distance from } (3, 4) \text{ to } (10, 0) = \sqrt{7^2 + 4^2} = \sqrt{65}$$

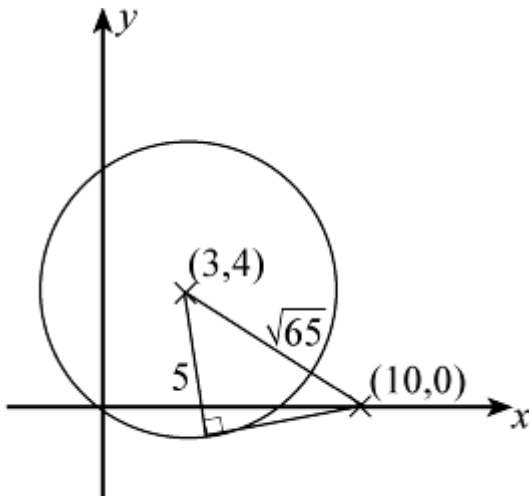

$$\text{Length of tangent} = \sqrt{\sqrt{65}^2 - 5^2} = \sqrt{40} = 2\sqrt{10}$$

Solutionbank C2

Edexcel Modular Mathematics for AS and A-Level

Practice paper Exercise 1, Question 7

Question:

A father promises his daughter an eternal gift on her birthday. On day 1 she receives £75 and each following day she receives $\frac{2}{3}$ of the amount given to her the day before. The father promises that this will go on for ever.

- (a) Show that after 2 days the daughter will have received £125. (2)
- (b) Find how much money the father should set aside to ensure that he can cover the cost of the gift. (3)
After k days the total amount of money that the daughter will have received exceeds £200.
- (c) Find the smallest value of k . (5)

Solution:

(a) Day 1 = £ 75, day 2 = £ 50, total = £ 125

(b) $a = 75$, $r = \frac{2}{3}$ —geometric series

$$S_{\infty} = \frac{a}{1-r} = \frac{75}{1-\frac{2}{3}}$$

Amount required = £ 225

$$(c) S_k = \frac{a(1-r^k)}{1-r}$$

$$\text{Require } \frac{75 [1 - (\frac{2}{3})^k]}{1 - \frac{2}{3}} > 200$$

$$\text{i.e. } 225 \left[1 - \left(\frac{2}{3} \right)^k \right] > 200$$

$$\Rightarrow 1 - \left(\frac{2}{3} \right)^k > \frac{8}{9}$$

$$\Rightarrow \frac{1}{9} > \left(\frac{2}{3} \right)^k$$

$$\text{Take logs: } \log \left(\frac{1}{9} \right) > k \log \left(\frac{2}{3} \right)$$

Since $\log \left(\frac{2}{3} \right)$ is negative, when we divide by this the inequality will change around.

$$\text{So } k > \frac{\log \left(\frac{1}{9} \right)}{\log \left(\frac{2}{3} \right)}$$

i.e. $k > 5.419 \dots$

So need $k = 6$

© Pearson Education Ltd 2008

Solutionbank C2

Edexcel Modular Mathematics for AS and A-Level

Practice paper Exercise 1, Question 8

Question:

Given $I = \int_1^3 \left(\frac{1}{x^2} + 3\sqrt{x} \right) dx$:

(a) Use the trapezium rule with the table below to estimate I to 3 significant figures. (4)

x	1	1.5	2	2.5	3
y	4	4.119	4.493	4.903	5.307

(b) Find the exact value of I . (4)

(c) Calculate, to 1 significant figure, the percentage error incurred by using the trapezium rule as in part (a) to estimate I . (2)

Solution:

(a) $h = 0.5$

$$\begin{aligned}
 I &\approx \frac{0.5}{2} \left[4 + 2 \left(4.119 + 4.493 + 4.903 \right) + 5.307 \right] \\
 &= \frac{1}{4} \left[36.337 \right] \\
 &= 9.08425
 \end{aligned}$$

(b) $I = \int_1^3 \left(x^{-2} + 3x^{\frac{1}{2}} \right) dx$

$$\begin{aligned}
 &= \left[\frac{x^{-1}}{-1} + \frac{3x^{\frac{3}{2}}}{\frac{3}{2}} \right]_1^3 \\
 &= \left[-\frac{1}{x} + 2x^{\frac{3}{2}} \right]_1^3 \\
 &= \left(-\frac{1}{3} + 2 \times 3\sqrt{3} \right) - \left(-1 + 2 \right) \\
 &= 6\sqrt{3} - \frac{4}{3}
 \end{aligned}$$

(c) Percentage error = $\frac{|6\sqrt{3} - \frac{4}{3} - 9.08425|}{6\sqrt{3} - \frac{4}{3}} \times 100 = 0.279 \dots \% = 0.3 \%$

Solutionbank C2

Edexcel Modular Mathematics for AS and A-Level

Practice paper Exercise 1, Question 9

Question:

The curve C has equation $y = 6x^{\frac{7}{3}} - 7x^2 + 4$.

(a) Find $\frac{dy}{dx}$. (2)

(b) Find $\frac{d^2y}{dx^2}$. (2)

(c) Use your answers to parts (a) and (b) to find the coordinates of the stationary points on C and determine their nature. (9)

Solution:

(a) $y = 6x^{\frac{7}{3}} - 7x^2 + 4$

$$\frac{dy}{dx} = 6 \times \frac{7}{3} x^{\frac{4}{3}} - 14x$$

$$\frac{dy}{dx} = 14x^{\frac{4}{3}} - 14x$$

(b) $\frac{d^2y}{dx^2} = \frac{56}{3} x^{\frac{1}{3}} - 14$

(c) $\frac{dy}{dx} = 0 \Rightarrow x^{\frac{4}{3}} - x = 0 \Rightarrow x \left(x^{\frac{1}{3}} - 1 \right) = 0$

So $x = 0$ or 1

$x = 0 \Rightarrow \frac{d^2y}{dx^2} = -14 < 0 \therefore (0, 4)$ is a maximum

$x = 1 \Rightarrow \frac{d^2y}{dx^2} = \frac{56}{3} - 14 > 0 \therefore (1, 3)$ is a minimum

Solutionbank C1

Edexcel Modular Mathematics for AS and A-Level

Algebra and functions

Exercise A, Question 1

Question:

Simplify $\frac{x^2 - 2x - 3}{x^2 - 7x + 12}$.

Solution:

$$\frac{x^2 - 2x - 3}{x^2 - 7x + 12}$$

$$= \frac{(x - 3)(x + 1)}{(x - 3)(x - 4)}$$

$$= \frac{x + 1}{x - 4}$$

Factorise $x^2 - 2x - 3$:

$$(-3) \times (+1) = -3$$

$$(-3) + (+1) = -2$$

$$\text{so } x^2 - 2x - 3 = (x - 3)(x + 1)$$

Factorise $x^2 - 7x + 12$:

$$(-3) \times (-4) = +12$$

$$(-3) + (-4) = -7$$

$$\text{so } x^2 - 7x + 12 = (x - 3)(x - 4)$$

Divide top and bottom by $(x - 3)$

Solutionbank C1

Edexcel Modular Mathematics for AS and A-Level

Algebra and functions

Exercise A, Question 2

Question:

In $\triangle ABC$, $AB = \sqrt{5}\text{cm}$, $\angle ABC = 45^\circ$, $\angle BCA = 30^\circ$. Find the length of BC .

Solution:

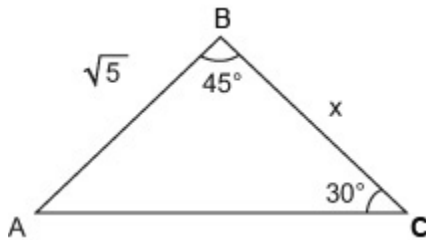

$$\frac{x}{\sin A} = \frac{\sqrt{5}}{\sin 30^\circ}$$

$$A + 30 + 45 = 180^\circ$$

$$A = 105^\circ$$

$$\text{so } \frac{x}{\sin 105^\circ} = \frac{\sqrt{5}}{\sin 30^\circ}$$

$$x = \frac{\sqrt{5}\sin 105^\circ}{\sin 30^\circ}$$

$$= 4.32$$

Draw a diagram to show the given information

Use the sine rule $\frac{a}{\sin A} = \frac{c}{\sin C}$, where $a = x$, $c = \sqrt{5}$ and $C = 30^\circ$

Find angle A. The angles in a triangle add to 180° .

Multiply throughout by $\sin 105^\circ$

Give answer to 3 significant figures

Solutionbank C1

Edexcel Modular Mathematics for AS and A-Level

Algebra and functions

Exercise A, Question 3

Question:

- (a) Write down the value of $\log_3 81$
- (b) Express $2 \log_a 4 + \log_a 5$ as a single logarithm to base a .

Solution:

(a)

$$\begin{aligned}\log_3 81 &= \log_3 (3^4) \\ &= 4\log_3 3 \\ &= 4 \times 1 \\ &= 4\end{aligned}$$

Write 81 as a power of 3, $81 = 3 \times 3 \times 3 \times 3 = 3^4$.

Use the power law: $\log_a (x^k) = k\log_a x$, so that $\log_3 (3^4) = 4\log_3 3$

Use $\log_a a = 1$, so that $\log_3 3 = 1$.

(b)

$$\begin{aligned}2\log_a 4 + \log_a 5 \\ &= \log_a 4^2 + \log_a 5 \\ &= \log_a (4^2 \times 5) \\ &= \log_a 80\end{aligned}$$

Use the power law: $\log_a (x^k) = k\log_a x$, so that

$$2\log_a 4 = \log_a 4^2$$

Use the multiplication law: $\log_a xy = \log_a x + \log_a y$ so that $\log_a 4^2 + \log_a 5 = \log_a (4^2 \times 5)$

Solutionbank C1

Edexcel Modular Mathematics for AS and A-Level

Algebra and functions

Exercise A, Question 4

Question:

P is the centre of the circle $(x - 1)^2 + (y + 4)^2 = 81$.

Q is the centre of the circle $(x + 3)^2 + y^2 = 36$.

Find the exact distance between the points P and Q .

Solution:

$$(x - 1)^2 + (y + 4)^2 = 81$$

The Coordinates of P are $(1, -4)$. Compare $(x - 1)^2 + (y + 4)^2 = 81$ to $(x - a)^2 + (y - b)^2 = r^2$, where (a, b) is the centre.

$$(x + 3)^2 + y^2 = 36$$

The Coordinates of Q are $(-3, 0)$. Compare $(x + 3)^2 + y^2 = 36$ to $(x - a)^2 + (y - b)^2 = r^2$ where (a, b) is the centre.

$$\begin{aligned} \underline{PQ} &= \sqrt{(-3 - 1)^2 + (0 - (-4))^2} \\ &= \sqrt{(-4)^2 + (4)^2} \\ &= \sqrt{16 + 16} \\ &= \sqrt{32} \end{aligned}$$

use $d = \sqrt{[(x_2 - x_1)^2 + (y_2 - y_1)^2]}$, where $(x_1, y_1) = (1, -4)$ and $(x_2, y_2) = (-3, 0)$

Solutionbank C1

Edexcel Modular Mathematics for AS and A-Level

Algebra and functions

Exercise A, Question 5

Question:

Divide $2x^3 + 9x^2 + 4x - 15$ by $(x + 3)$.

Solution:

$$\begin{array}{r}
 2x^2 \\
 x + 3 \overline{) 2x^3 + 9x^2 + 4x - 15} \\
 \underline{2x^3 + 6x^2} \\
 3x^2 + 4x
 \end{array}$$

$$\begin{array}{r}
 2x^2 + 3x \\
 x + 3 \overline{) 2x^3 + 9x^2 + 4x - 15} \\
 \underline{2x^3 + 6x^2} \\
 3x^2 + 4x \\
 \underline{3x^2 + 9x} \\
 -5x - 15
 \end{array}$$

$$\begin{array}{r}
 2x^2 + 3x - 5 \\
 x + 3 \overline{) 2x^3 + 9x^2 + 4x - 15} \\
 \underline{2x^3 + 6x^2} \\
 3x^2 + 4x \\
 \underline{3x^2 + 9x} \\
 -5x - 15 \\
 \underline{-5x - 15} \\
 0
 \end{array}$$

So $2x^3 + 9x^2 + 4x - 15 \div (x + 3) = 2x^2 + 3x - 5$.

Start by dividing the first term of the polynomial by x , so that $2x^3 \div x = 2x^2$. Next multiply $(x + 3)$ by $2x^2$, so that $2x^2 \times (x + 3) = 2x^3 + 6x^2$. Now subtract, so that $(2x^3 + 9x^2) - (2x^3 + 6x^2) = 3x^2$. Copy $+ 4x$.

Repeat the method. Divide $3x^2$ by x , so that $3x^2 \div x = 3x$. Multiply $(x + 3)$ by $3x$, so that $3x \times (x + 3) = 3x^2 + 9x$. Subtract, so that $(3x^2 + 4x) - (3x^2 + 9x) = -5x$. Copy $- 15$.

Repeat the method. Divide $-5x$ by x , so that $-5x \div x = -5$. Multiply $(x + 3)$ by -5 , so that $-5 \times (x + 3) = -5x - 15$. Subtract, so that $(-5x - 15) - (-5x - 15) = 0$.

Solutionbank C1

Edexcel Modular Mathematics for AS and A-Level

Algebra and functions

Exercise A, Question 6

Question:

In $\triangle ABC$, $AB = 5\text{ cm}$, $BC = 9\text{ cm}$ and $CA = 6\text{ cm}$. Show that $\cos \angle TRS = -\frac{1}{3}$.

Solution:

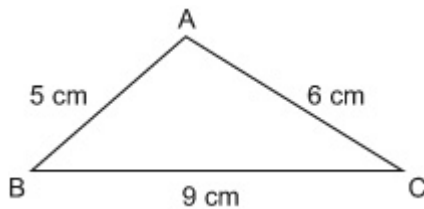

Draw a diagram using the given data.

$$\begin{aligned}\cos \angle BAC &= \frac{5^2 + 6^2 - 9^2}{2 \times 5 \times 6} \\ &= \frac{25 + 36 - 81}{60} \\ &= \frac{-20}{60} \\ &= \frac{-1}{3}\end{aligned}$$

Use the Cosine rule $\cos A = \frac{b^2 + c^2 - a^2}{2bc}$, where

$A = \angle BAC$, $a = 9$ (cm) , $b = 6$ (cm) , $c = 5$ (cm)

Solutionbank C1

Edexcel Modular Mathematics for AS and A-Level

Algebra and functions

Exercise A, Question 7

Question:

(a) Find, to 3 significant figures, the value of x for which $5^x = 0.75$

(b) Solve the equation $2 \log_5 x - \log_5 3x = 1$

Solution:

(a)

$$5^x = 0.75$$

$$\log_{10} (5^x) = \log_{10} 0.75$$

$$x \log_{10} 5 = \log_{10} 0.75$$

$$x = \frac{\log_{10} 0.75}{\log_{10} 5}$$

$$= -0.179$$

Take logs to base 10 of each side.

Use the Power law: $\log_a (x^k) = k \log_a x$ so that $\log_{10} (5^x) = x \log_{10} 5$

Divide both sides by $\log_{10} 5$

Give answer to 3 significant figures

(b)

$$2 \log_5 x - \log_5 3x = 1$$

$$\log_5 (x^2) - \log_5 3x = 1$$

$$\log_5 \left(\frac{x^2}{3x} \right) = 1$$

$$\log_5 \left(\frac{x}{3} \right) = 1$$

$$\log_5 \left(\frac{x}{3} \right) = \log_5 5$$

$$\text{so } \frac{x}{3} = 5$$

$$x = 15.$$

Use the Power law: $\log_a (x^k) = k \log_a x$ so that

$$2 \log_5 x = \log_5 (x^2)$$

Use the division law: $\log_a \left(\frac{x}{y} \right) = \log_a x - \log_a y$ so

$$\text{that } \log_5 (x^2) - \log_5 (3x) = \log_5 \left(\frac{x^2}{3x} \right).$$

Simplify. Divide top and bottom by x , so that $\frac{x^2}{3x} = \frac{x}{3}$.

Use $\log_a a = 1$, so that $1 = \log_5 5$

Compare the logarithms, they each have the same base,

$$\text{so } \frac{x}{3} = 5.$$

Solutionbank C1

Edexcel Modular Mathematics for AS and A-Level

Algebra and functions

Exercise A, Question 8

Question:

The circle C has equation $(x + 4)^2 + (y - 1)^2 = 25$.

The point P has coordinates $(-1, 5)$.

- (a) Show that the point P lies on the circumference of C .
- (b) Show that the centre of C lies on the line $x - 2y + 6 = 0$.

Solution:

(a)

Substitute $(-1, 5)$ into $(x + 4)^2 + (y - 1)^2 = 25$.

$$(-1 + 4)^2 + (5 - 1)^2 = 25$$

$$\begin{aligned} (-1 + 4)^2 + (5 - 1)^2 &= 3^2 + 4^2 \\ &= 9 + 16 \\ &= 25 \text{ as required} \end{aligned}$$

so P lies on the circumference of the circle.

Any point (x, y) on the circumference of a circle satisfies the equation of the circle.

(b)

The Centre of C is $(-4, 1)$

Compare $(x + 4)^2 + (y - 1)^2 = 25$ to $(x - a)^2 + (y - b)^2 = r^2$ where (a, b) is the centre.

Substitute $(-4, 1)$ into

$$x - 2y + 6 = 0$$

$$\begin{aligned} (-4) - 2(1) + 6 &= -4 - 2 + 6 = 0 \text{ As required} \end{aligned}$$

so the centre of C lies on the line $x - 2y + 6 = 0$.

Any point (x, y) on a line satisfies the equation of the line.

Solutionbank C1

Edexcel Modular Mathematics for AS and A-Level

Algebra and functions

Exercise A, Question 9

Question:

(a) Show that $(2x - 1)$ is a factor of $2x^3 - 7x^2 - 17x + 10$.

(b) Factorise $2x^3 - 7x^2 - 17x + 10$ completely.

Solution:

(a)

$$f(x) = 2x^3 - 7x^2 - 17x + 10$$

$$f\left(\frac{1}{2}\right) = 2\left(\frac{1}{2}\right)^3 - 7\left(\frac{1}{2}\right)^2 - 17\left(\frac{1}{2}\right) + 10$$

$$= 2 \times \frac{1}{8} - 7 \times \frac{1}{4} - 17 \times \frac{1}{2} + 10$$

$$= \frac{1}{4} - \frac{7}{4} - \frac{17}{2} + 10$$

$$= 0$$

so, $(2x - 1)$ is a factor of $2x^3 - 7x^2 - 17x + 10$.

Use the remainder theorem: if $f(x)$ is divided by $(ax - b)$, then the remainder is $g\left(\frac{b}{a}\right)$.

Compare $(2x - 1)$ to $(ax - b)$, so $a = 2$, $b = 1$ and the remainder is $f\left(\frac{1}{2}\right)$.

The remainder = 0, so $(2x - 1)$ is a factor of $2x^3 - 7x^2 - 17x + 10$.

(b)

$$\begin{array}{r}
 x^2 - 3x - 10 \\
 2x - 1 \overline{) 2x^3 - 7x^2 - 17x + 10} \\
 \underline{2x^2 - x^2} \\
 -6x^2 - 17x \\
 \underline{-6x^2 + 3x} \\
 -20x + 10 \\
 \underline{-20x - 10} \\
 0
 \end{array}$$

$$\text{so } 2x^3 - 7x^2 - 17x + 10 = (2x - 1)$$

$$(x^2 - 3x - 10)$$

$$= (2x - 1)$$

$$(x - 5)(x + 2)$$

First divide $2x^3 - 7x^2 - 17x + 10$ by $(2x - 1)$.

Now factorise $x^2 - 3x - 10$:

$$(-5) \times (+2) = -10$$

$$(-5) + (+2) = -3$$

$$\text{so } x^2 - 3x - 10 = (x - 5)(x + 2).$$

Solutionbank C1

Edexcel Modular Mathematics for AS and A-Level

Algebra and functions

Exercise A, Question 10

Question:

In $\triangle PQR$, $QR = 8$ cm, $PR = 6$ cm and $\angle PQR = 40^\circ$.

Calculate the two possible values of $\angle QPR$.

Solution:

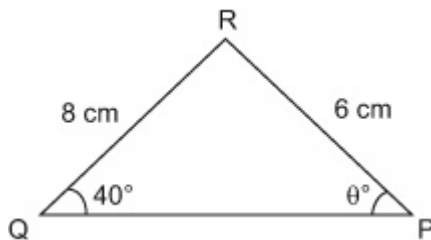

Draw a diagram using the given data.

Let $\angle QPR = \theta^\circ$

$$\frac{\sin \theta}{8} = \frac{\sin 40^\circ}{6}$$

$\theta = 59.0^\circ$ and 121.0°

Use $\frac{\sin P}{p} = \frac{\sin Q}{q}$, where $P = \theta^\circ$, $p = 8$ (cm),
 $Q = 40^\circ$, $q = 6$ (cm) .

As $\sin (180 - \theta)^\circ = \sin \theta^\circ$,
 $\theta = 180^\circ - 59.0^\circ = 121.0^\circ$ is the other possible
 answer.

Solutionbank C1

Edexcel Modular Mathematics for AS and A-Level

Algebra and functions

Exercise A, Question 11

Question:

(a) Express $\log_2 \left(\frac{4a}{b^2} \right)$ in terms of $\log_2 a$ and $\log_2 b$.

(b) Find the value of $\log_{27} \frac{1}{9}$.

Solution:

$$(a) \log_2 \left(\frac{4a}{b^2} \right)$$

$$= \log_2 4a - \log_2 (b^2)$$

$$= \log_2 4 + \log_2 a - \log_2 (b^2)$$

$$= 2 + \log_2 a - 2 \log_2 b$$

Use the division law: $\log_a \left(\frac{x}{y} \right) = \log_a x - \log_a y$, so

$$\text{that } \log_2 \left(\frac{4a}{b^2} \right) = \log_2 4a - \log_2 b^2.$$

Use the multiplication law: $\log_a (xy) = \log_a x + \log_a y$, so that

$$\log_2 4a = \log_2 4 + \log_2 a$$

Simplify $\log_2 4$

$$\log_2 4 = \log_2 (2^2)$$

$$= 2 \log_2 2$$

$$= 2 \times 1$$

$$= 2$$

Use the power law: $\log_a (x^K) = K \log_a x$, so that $\log_2 (b^2) = 2 \log_2 b$.

(b)

$$\log_{27} \left(\frac{1}{9} \right) = \frac{\log_{10} \left(\frac{1}{9} \right)}{\log_{10} (27)}$$

$$= -\frac{2}{3}$$

Change the base of the logarithm. Use $\log_a x = \frac{\log_b x}{\log_b a}$, so

$$\text{that } \log_{27} \left(\frac{1}{9} \right) = \frac{\log_{10} \left(\frac{1}{9} \right)}{\log_{10} (27)}$$

Alternative method:

$$\log_{27} \left(\frac{1}{9} \right) = \log_{27} (9^{-1})$$

$$= -\log_{27} (9)$$

Use index rules: $x^{-1} = \frac{1}{x}$, so that $\frac{1}{9} = 9^{-1}$

Use the power law $\log_a (x^K) = K \log_a x$.

$$= -\log_{27}(3^2)$$

$$= -2\log_{27}(3)$$

$$= -2\log_{27}\left(27^{\frac{1}{3}}\right)$$

$$= \frac{-2}{3}\log_{27}27$$

$$= \frac{-2}{3} \times 1$$

$$= \frac{-2}{3}$$

Use the power law $\log_a(x^K) = K\log_ax$.

$$27 = 3 \times 3 \times 3, \text{ so } 3 = \sqrt[3]{27} = 27^{\frac{1}{3}}$$

Use the power law $\log_a(x^K) = K\log_ax$.

Use $\log_aa = 1$, so that $\log_{27}27 = 1$

Solutionbank C1

Edexcel Modular Mathematics for AS and A-Level

Algebra and functions

Exercise A, Question 12

Question:

The points $L(3, -1)$ and $M(5, 3)$ are the end points of a diameter of a circle, centre N .

- (a) Find the exact length of LM .
- (b) Find the coordinates of the point N .
- (c) Find an equation for the circle.

Solution:

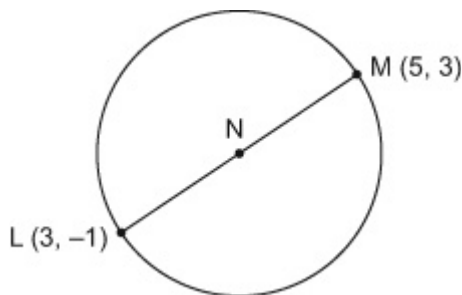

Draw a diagram using the given information

(a)

$$\begin{aligned}
 LM &= \sqrt{(5-3)^2 + 3 - (-1)^2} && \text{Use } d = \sqrt{[(x_2 - x_1)^2 + (y_2 - y_1)^2]} \text{ with} \\
 &= \sqrt{(2)^2 + (4)^2} && (x_1, y_1) = (3, -1) \text{ and } (x_2, y_2) = (5, 3) \\
 &= \sqrt{4 + 16} \\
 &= \sqrt{20}
 \end{aligned}$$

(b)

$$\begin{aligned}
 \text{The Coordinates of } N &\text{ are } \left(\frac{3+5}{2}, \frac{-1+3}{2} \right) = (4, 1). && \text{Use } \left(\frac{x_1+x_2}{2}, \frac{y_1+y_2}{2} \right) \text{ with } (x_1, y_1) = (3, -1) \\
 &&& \text{and } (x_2, y_2) = (5, 3).
 \end{aligned}$$

(c)

$$\begin{aligned}
 \text{The equation of the Circle is} &&& \text{Use } (x-a)^2 + (y-b)^2 = r^2 \text{ where } (a, b) \text{ is the} \\
 (x-4)^2 + (y-1)^2 &= \left(\frac{\sqrt{20}}{2} \right)^2 && \text{centre and } r \text{ is the radius. Here } (a, b) = (4, 1) \text{ and} \\
 &&& r = \frac{\sqrt{20}}{2}. \\
 (x-4)^2 + (y-1)^2 &= 5 && \left(\frac{\sqrt{20}}{2} \right)^2 = \frac{\sqrt{20}}{2} \times \frac{\sqrt{20}}{2} = \frac{20}{4} = 5
 \end{aligned}$$

Solutionbank C1

Edexcel Modular Mathematics for AS and A-Level

Algebra and functions

Exercise A, Question 13

Question:

$$f(x) = 3x^3 + x^2 - 38x + c$$

Given that $f(3) = 0$,

- (a) find the value of c ,
- (b) factorise $f(x)$ completely,
- (c) find the remainder when $f(x)$ is divided by $(2x - 1)$.

Solution:

$$f(x) = 3x^3 + x^2 - 38x + c$$

(a)

$$3(3)^3 + (3)^2 - 38(3) + c = 0$$

$$3 \times 27 + 9 - 114 + c = 0$$

$$c = 24$$

$$\text{so } f(x) = 3x^3 + x^2 - 38x + 24.$$

Substitute $x = 3$ into the polynomial.

(b)

$f(3) = 0$, so $(x - 3)$ is a factor of $3x^3 + x^2 - 38x + 24$

$$\begin{array}{r} 3x^2 - 10x - 8 \\ x - 3 \overline{) 3x^3 + x^2 - 38x + 24} \\ \underline{3x^3 - 9x^2} \\ 10x^2 - 38x \\ \underline{10x^2 - 30x} \\ -8x - 24 \\ \underline{-8x + 24} \\ 0 \end{array}$$

Use the factor theorem: If $f(p) = 0$, then $(x - p)$ is a factor of $f(x)$. Here $p = 3$

First divide $3x^3 + x^2 - 38x + 24$ by $(x - 3)$.

$$\begin{aligned} \text{so } 3x^3 + x^2 - 38x + 24 &= (x - 3) \\ &\quad (3x^2 + 10x - 8) \\ &= (x - 3)(3x - 2) \\ &\quad (x + 4). \end{aligned}$$

$$\begin{aligned} \text{Now factorise } 3x^2 + 10x - 8. \quad ac &= -24 \text{ and} \\ (-2) + (+12) &= +10 (=b) \text{ so} \\ 3x^2 + 10x - 8 &= 3x^2 - 2x + 12x - 8. \\ &= x(3x - 2) + 4(3x - 2) \\ &= (3x - 2)(x + 4) \end{aligned}$$

(c)

The remainder when $f(x)$ is divided by $(2x - 1)$ is $f(\frac{1}{2})$

Use the rule that if $f(x)$ is divided by $(ax - b)$ then the remainder is $f(\frac{a}{b})$.

$$\begin{aligned}f\left(\frac{1}{2}\right) &= 3\left(\frac{1}{2}\right)^3 + \left(\frac{1}{2}\right)^2 - 38\left(\frac{1}{2}\right) \\ &\quad + 24 \\ &= \frac{3}{8} + \frac{1}{4} - 19 + 24 \\ &= 5\frac{5}{8}\end{aligned}$$

© Pearson Education Ltd 2008

Solutionbank C1

Edexcel Modular Mathematics for AS and A-Level

Algebra and functions

Exercise A, Question 14

Question:

In $\triangle ABC$, $AB = 5\text{cm}$, $BC = (2x - 3)\text{ cm}$, $CA = (x + 1)\text{ cm}$ and $\angle ABC = 60^\circ$.

- (a) Show that x satisfies the equation $x^2 - 8x + 16 = 0$.
- (b) Find the value of x .
- (c) Calculate the area of the triangle, giving your answer to 3 significant figures.

Solution:

(a)

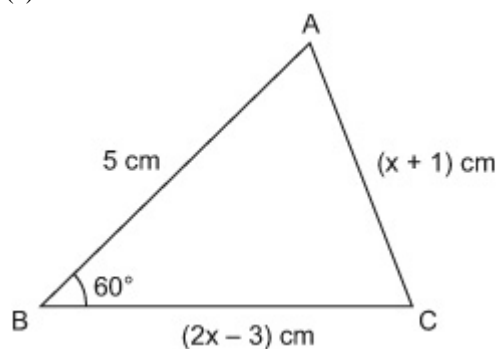

$$(x + 1)^2 = (2x - 3)^2 + 5^2 - 2(2x - 3) \times 5 \times \cos 60^\circ$$

$$(x + 1)^2 = (2x - 3)^2 + 5^2 - 5(2x - 3)$$

$$x^2 + 2x + 1 = 4x^2 - 12x + 9 + 5^2 - 10x + 15$$

$$3x^2 - 24x + 48 = 0$$

$$x^2 - 8x + 16 = 0$$

(b)

$$x^2 - 8x + 16 = 0$$

$$(x - 4)(x - 4) = 0$$

$$x = 4$$

(c)

Draw a diagram using the given data.

Use the cosine rule:

$$b^2 = a^2 + c^2 - 2ac \cos B, \text{ where } a = (2x - 3)\text{ cm}, b = (x + 1)\text{ cm}, c = 5\text{ cm}, B = 60^\circ.$$

$$\cos 60^\circ = \frac{1}{2}, \text{ so } 2(2x - 3)$$

$$\times 5 \times \cos 60^\circ$$

$$= 2(2x - 3) \times 5 \times \frac{1}{2}$$

$$= 5(2x - 3)$$

Factorize $x^2 - 8x + 16 = 0$

$$(-4) \times (-4) = +16$$

$$(-4) + (-4) = -8$$

$$\text{so } x^2 - 8x + 16 = (x - 4)(x - 4)$$

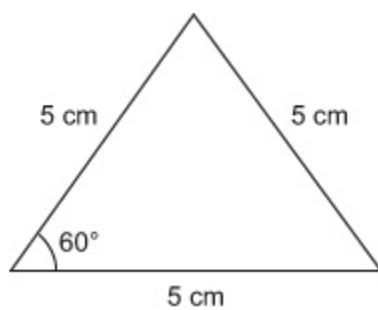

$$\begin{aligned}\text{Area} &= \frac{1}{2} \times 5 \times 5 \sin 60^\circ \\ &= 10.8\text{cm}^2\end{aligned}$$

Draw the diagram using $x = 4$

Use Area = $\frac{1}{2}ac \sin B$, where
 $a = 5\text{cm}$, $c = 5\text{cm}$, $B = 60^\circ$

Solutionbank C1

Edexcel Modular Mathematics for AS and A-Level

Algebra and functions

Exercise A, Question 15

Question:

(a) Solve $0.6^{2x} = 0.8$, giving your answer to 3 significant figures.

(b) Find the value of x in $\log_x 243 = 2.5$

Solution:

(a) $0.6^{2x} = 0.8$

$$\log_{10} 0.6^{2x} = \log_{10} 0.8$$

$$2x \log_{10} 0.6 = \log_{10} 0.8$$

$$2x = \frac{\log_{10} 0.8}{\log_{10} 0.6}$$

$$x = \frac{1}{2} \left(\frac{\log_{10} 0.8}{\log_{10} 0.6} \right)$$

$$= 0.218$$

Take logs to base 10 of each side.

Use the power law: $\log_a (x^K) = K \log_a x$, so that

$$\log_{10} 0.6^{2x} = 2x \log_{10} 0.6.$$

Divide throughout by $\log_{10} 0.6$

(b)

$$\log_x 243 = 2.5$$

$$\frac{\log_{10} 243}{\log_{10} x} = 2.5$$

$$\log_{10} x = \frac{\log_{10} 243}{2.5}$$

$$\text{so } x = 10 \left(\frac{\log_{10} 243}{2.5} \right)$$

$$= 9$$

Change the base of the logarithm. Use $\log_a x = \frac{\log_b x}{\log_b a}$, so

$$\text{that } \log_x 243 = \frac{\log_{10} 243}{\log_{10} x}.$$

Rearrange the equation for x .

$\log_a n = x$ means that $a^x = n$, so $\log_{10} x = C$ means

$$x = 10^c, \text{ where } c = \frac{\log_{10} 243}{2.5}.$$

Solutionbank C1

Edexcel Modular Mathematics for AS and A-Level

Algebra and functions

Exercise A, Question 16

Question:

Show that part of the line $3x + y = 14$ forms a chord to the circle $(x - 2)^2 + (y - 3)^2 = 5$ and find the length of this chord.

Solution:

$$\begin{aligned}(x - 2)^2 + (y - 3)^2 &= 5 \\ 3x + y &= 14 \\ y &= 14 - 3x\end{aligned}$$

Solve the equations simultaneously.

$$(x - 2)^2 + (14 - 3x - 3)^2 = 5 \quad \text{Rearrange } 3x + y = 14 \text{ for } y \text{ and substitute into } (x - 2)^2 + (y - 3)^2 = 5.$$

$$(x - 2)^2 + (11 - 3x)^2 = 5 \quad \text{Expand and simplify.}$$

$$(x - 2)^2 = x^2 - 4x + 4$$

$$(11 - 3x)^2 = 121 - 66x + 9x^2$$

$$x^2 - 4x + 4 + 121 - 66x + 9x^2 = 5$$

$$10x^2 - 70x + 120 = 0 \quad \text{Divide throughout by 10}$$

$$x^2 - 7x + 12 = 0 \quad \text{Factorize } x^2 - 7x + 12 = 0$$

$$(-4) \times (-3) = +12$$

$$(-4) + (-3) = -7$$

$$\text{so } x^2 - 7x + 12 = (x - 3)(x - 4)$$

$$\text{so } x = 3, x = 4$$

Two values of x , so two points of intersection.

So part of the line forms a chord to the Circle .

$$\begin{aligned}\text{When } x = 3, y &= 14 - 3(3) \\ &= 14 - 9 \\ &= 5\end{aligned}$$

Find the coordinates of the points where the line meets the circle. Substitute $x = 3$ into $y = 14 - 3x$. Substitute $x = 4$ into $y = 14 - 3x$

$$\begin{aligned}\text{When } x = 4, y &= 14 - 3(4) \\ &= 14 - 12 \\ &= 2\end{aligned}$$

So the line meets the chord at the points (3,5) and (4,2).

The distance between these points is

$$\begin{aligned}\sqrt{(4 - 3)^2 + (2 - 5)^2} &= \sqrt{1^2 + 9} \\ &= \sqrt{1 + 9} \\ &= \sqrt{10}\end{aligned}$$

Find the distance between the points (3,5) and (4,2) use $\sqrt{(x_2 - x_1)^2 + (y_2 - y_1)^2}$ with $(x_1, y_1) = (3, 5)$ and $(x_2, y_2) = (4, 2)$.

Solutionbank C1

Edexcel Modular Mathematics for AS and A-Level

Algebra and functions

Exercise A, Question 17

Question:

$$g(x) = x^3 - 13x + 12$$

- (a) Find the remainder when $g(x)$ is divided by $(x - 2)$.
- (b) Use the factor theorem to show that $(x - 3)$ is a factor of $g(x)$.
- (c) Factorise $g(x)$ completely.

Solution:

(a) $g(x) = x^3 - 13x + 12$

$$\begin{aligned} g(2) &= (2)^3 - 13(2) + 12 \\ &= 8 - 26 + 12 \\ &= -6. \end{aligned}$$

Use the remainder theorem: If $g(x)$ is divided by $(ax - b)$, then the remainder is $g\left(\frac{b}{a}\right)$. Compare $(x - 2)$ to

$(ax - b)$, so $a = 1$, $b = 2$ and the remainder is $g\left(\frac{2}{1}\right)$, ie $g(2)$.

(b)

$$\begin{aligned} g(3) &= (3)^3 - 13(3) + 12 \\ &= 27 - 39 + 12 \\ &= 0 \end{aligned}$$

Use the factor theorem: If $g(p) = 0$, then $(x - p)$ is a factor of $g(x)$. Here $p = 3$

so $(x - 3)$ is a factor of $x^3 - 13x + 12$.

(c)

$$\begin{array}{r} x^2 + 3x - 4 \\ x - 3 \overline{) x^3 + 0x^2 - 13x + 12} \\ \underline{x^3 - 3x^2} \\ 3x^2 - 13x \\ \underline{3x^2 - 9x} \\ -4x + 12 \\ \underline{-4x + 12} \\ 0 \end{array}$$

First divide $x^3 - 13x + 12$ by $(x - 3)$. Use $0x^2$ so that the sum is laid out correctly

$$\begin{aligned} \text{so } x^3 - 13x + 12 &= (x - 3) \\ & (x^2 + 3x - 4) \\ &= (x - 3)(x + 4)(x - 1). \end{aligned}$$

Factorize $x^2 + 3x - 4$:

$$\begin{aligned} (+4) \times (-1) &= -4 \\ (+4) + (-1) &= +3 \\ \text{so } x^2 + 3x - 4 &= (x + 4)(x - 1). \end{aligned}$$

Solutionbank C1

Edexcel Modular Mathematics for AS and A-Level

Algebra and functions

Exercise A, Question 18

Question:

The diagram shows $\triangle ABC$, with $BC = x$ m, $CA = (2x - 1)$ m and $\angle BCA = 30^\circ$.

Given that the area of the triangle is 2.5 m^2 ,

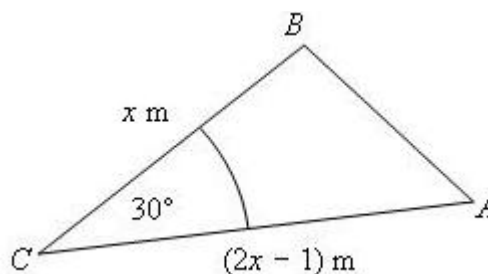

(a) find the value of x ,

(b) calculate the length of the line AB , giving your answer to 3 significant figures.

Solution:

(a)

$$\frac{1}{2}x(2x - 1) \sin 30^\circ = 2.5$$

$$\frac{1}{2}x(2x - 1) \times \frac{1}{2} = 2.5$$

$$x(2x - 1) = 10$$

$$2x^2 - x - 10 = 0$$

$$(x + 2)(2x - 5) = 0$$

$$x = -2 \text{ and } x = \frac{5}{2}$$

so $x = 2.5$ m

(b)

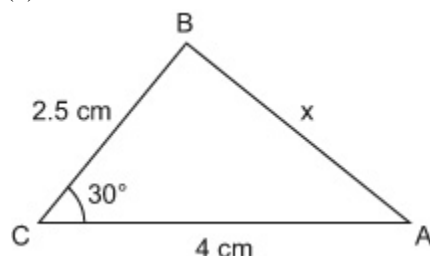

$$x^2 = 2.5^2 + 4^2 - 2 \times 2.5 \times 4 \times \cos 30^\circ \quad \text{Use the cosine rule } c^2 = a^2 + b^2 - 2ab \cos C, \text{ where}$$

Here $a = x$ (m), $b = (2x - 1)$ (m) and angle $C = 30^\circ$, so use area $= \frac{1}{2}ab \sin C$.

$$\sin 30^\circ = \frac{1}{2}$$

Multiply both side by 4

Expand the brackets and rearrange into the form

$$ax^2 + bx + c = 0$$

Factorize $2x^2 - x - 10 = 0$: $ac = -20$ and $(+4) + (-5) = -1$ so

$$\begin{aligned} 2x^2 - x - 10 &= 2x^2 + 4x - 5x - 10 \\ &= 2x(x + 2) - 5(x + 2) \\ &= (x + 2)(2x - 5) \end{aligned}$$

$x = -2$ is not feasible for this problem as BC would have a negative length.

Draw the diagram using $x = 2.5$ m

$$x = 2.22 \text{ m}$$

$$c = x \text{ (m) } , a = 2.5 \text{ (m) } , b = 4 \text{ (m) } , C = 30^\circ$$

© Pearson Education Ltd 2008

Solutionbank C1

Edexcel Modular Mathematics for AS and A-Level

Algebra and functions

Exercise A, Question 19

Question:

(a) Solve $3^{2x-1} = 10$, giving your answer to 3 significant figures.

(b) Solve $\log_2 x + \log_2 (9 - 2x) = 2$

Solution:

(a)

$$3^{2x-1} = 10$$

$$\log_{10} (3^{2x-1}) = \log_{10} 10$$

$$(2x-1) \log_{10} 3 = 1$$

$$2x-1 = \frac{1}{\log_{10} 3}$$

$$2x = \frac{1}{\log_{10} 3} + 1$$

$$x = \frac{\frac{1}{\log_{10} 3} + 1}{2}$$

$$x = 1.55$$

Take logs to base 10 of each side.

Use the power law: $\log_a (x^K) = K \log_a x$, so that $\log_{10} (3^{2x-1}) = (2x-1) \log_{10} 3$. Use $\log_a a = 1$ so that $\log_{10} 10 = 1$

Rearrange the expression, divide both sides by $\log_{10} 3$.

Add 1 to both sides.

Divide both sides by 2

(b)

$$\log_2 x + \log_2 (9 - 2x) = 2$$

$$\log_2 x (9 - 2x) = 2$$

$$\text{so } x(9 - 2x) = 2^2$$

$$x(9 - 2x) = 4$$

$$9x - 2x^2 = 4$$

$$2x^2 - 9x + 4 = 0$$

$$(x-4)(2x-1) = 0$$

$$x = 4, x = \frac{1}{2}$$

Use the multiplication law: $\log_a (xy) = \log_a x + \log_a y$ so that $\log_2 x + \log_2 (9 - 2x) = \log_2 x (9 - 2x)$.

$\log_a n = x$ means $a^x = n$ so $\log_2 x (9 - 2x) = 2$ means $2^2 = x(9 - 2x)$

Factorise $2x^2 - 9x + 4 = 0$ $ac = 8$, and $(-8) + (-1) = -9$ so

$$\begin{aligned} 2x^2 - 9x + 4 &= 2x^2 - 8x - x + 4 \\ &= 2x(x-4) - 1(x-4) \\ &= (x-4)(2x-1) \end{aligned}$$

Solutionbank C1

Edexcel Modular Mathematics for AS and A-Level

Algebra and functions

Exercise A, Question 20

Question:

Prove that the circle $(x + 4)^2 + (y - 5)^2 = 8^2$ lies completely inside the circle $x^2 + y^2 + 8x - 10y = 59$.

Solution:

(a)

$$x^2 + y^2 + 8x - 10y = 59$$

Write this circle in the form $(x - a)^2 + (y - b)^2 = r^2$

$$x^2 + 8x + y^2 - 10y = 59$$

Rearrange the equation to bring the x terms together and the y terms together.

$$\begin{aligned} (x + 4)^2 - 16 + (y - 5)^2 - 25 &= 59 \\ (x + 4)^2 + (y - 5)^2 &= 100 \end{aligned}$$

Complete the square, use $x^2 + 2ax = (x + a)^2 - a^2$ where $a = 4$, so that $x^2 + 8x = (x + 4)^2 - 4^2$, and where $a = -5$, so that $x^2 - 10x = (x - 5)^2 - 5^2$.

$$(x + 4)^2 + (y - 5)^2 = 10^2$$

The centre and radius of $x^2 + y^2 + 8x - 10y = 59$ are $(-4, 5)$ and 10.

Compare $(x + 4)^2 + (y - 5)^2 = 100$ to $(x - a)^2 + (y - b)^2 = r^2$, where (a, b) is the centre and r is the radius. Here $(a, b) = (-4, 5)$ and $r = 10$.

The centre and radius of $(x + 4)^2 + (y - 5)^2 = 8^2$ are $(-4, 5)$ and 8.

Compare $(x + 4)^2 + (y - 5)^2 = 8^2$ to $(x - a)^2 + (y - b)^2 = r^2$, where (a, b) is the centre and r is the radius. Here $(a, b) = (-4, 5)$ and $r = 8$.

Both circles have the same centre, but each has a different radius. So, $(x + 4)^2 + (y - 5)^2 = 8^2$ lies completely inside $x^2 + y^2 + 8x - 10y = 59$.

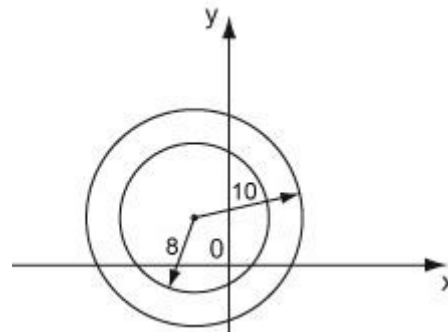

Solutionbank C1

Edexcel Modular Mathematics for AS and A-Level

Algebra and functions

Exercise A, Question 21

Question:

$f(x) = x^3 + ax + b$, where a and b are constants.

When $f(x)$ is divided by $(x - 4)$ the remainder is 32.

When $f(x)$ is divided by $(x + 2)$ the remainder is -10 .

(a) Find the value of a and the value of b .

(b) Show that $(x - 2)$ is a factor of $f(x)$.

Solution:

(a)

$$f(4) = 32$$

$$\text{so, } (4)^3 + 4a + b = 32$$

$$4a + b = -32$$

$$f(-2) = -10,$$

$$\text{so } (-2)^3 + a(-2) + b = 32$$

$$-8 - 2a + b = 32$$

$$-2a + b = 40$$

Solve simultaneously

$$4a + b = -32$$

$$-2a + b = 40$$

$$6a = -72$$

$$\text{so } a = -12$$

Substitute $a = -12$ into $4a + b = -32$

$$4(-12) + b = -32$$

$$-48 + b = -32$$

$$b = 16$$

Check $-2a + b = 40$

$$-2(-12) + 16 = 24 + 16 = 40$$

(correct)

$$\text{so } a = -12, b = 16.$$

$$\text{so } f(x) = x^3 - 12x + 16$$

(b)

$$f(2) = (2)^3 - 12(2) + 16$$

Use the remainder theorem: If $f(x)$ is divided by $(ax - b)$, then the remainder is $f\left(\frac{b}{a}\right)$. Compare $(x - 4)$ to $(ax - b)$, so $a = 1$, $b = 4$ and the remainder is $f(4)$.

Use the remainder theorem: Compare $(x + 2)$ to $(ax - b)$, so $a = 1$, $b = -2$ and the remainder is $f(-2)$.

Eliminate b : Subtract the equations, so $(4a + b) - (-2a + b) = 6a$ and $(-32) - (40) = -72$

Substitute $a = -12$ into one of the equations. Here we use $4a + b = -32$

Substitute the values of a and b into the other equation to check the answer. Here we use $-2a + b = 40$

Use the factor theorem: If $f(p) = 0$, then $(x - p)$ is a factor of $f(x)$. Here $p = 2$.

$$= 8 - 24 + 16$$

$$= 0$$

so $(x - 2)$ is a factor of $x^3 - 12x + 16$

© Pearson Education Ltd 2008

Solutionbank C1

Edexcel Modular Mathematics for AS and A-Level

Algebra and functions

Exercise A, Question 22

Question:

Ship *B* is 8 km, on a bearing of 30° , from ship *A*.

Ship *C* is 12 km, on a bearing of 140° , from ship *B*.

(a) Calculate the distance of ship *C* from ship *A*.

(b) Calculate the bearing of ship *C* from ship *A*.

Solution:

(a)

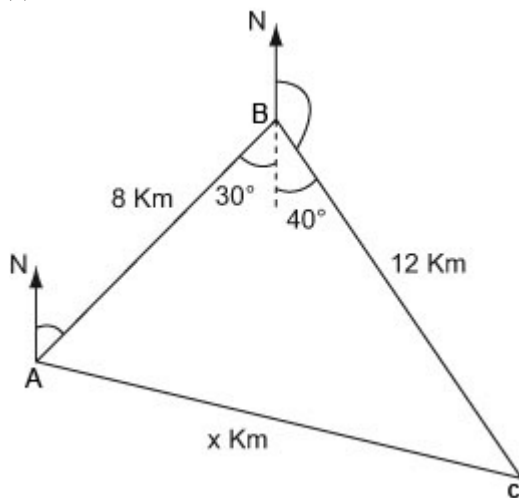

Draw a diagram using the given data.

Find the angle $\angle ABC$: Angles on a straight line add to 180° , so $140^\circ + 40^\circ = 180^\circ$. Alternate angles are equal ($= 30^\circ$) so $\angle ABC = 30^\circ + 40^\circ = 70^\circ$

$$x^2 = 8^2 + 12^2 - 2 \times 8 \times 12 \times \cos 70^\circ$$

You have $a = 12$ (km) , $c = 8$ (km) , $b = x$ (km) , $B = 70^\circ$. Use the cosine rule $b^2 = a^2 + c^2 - 2ac \cos B$

$$x = 11.93 \text{ km}$$

The distance of ship *C* from ship *A* is 11.93 km.

(b)

$$\frac{\sin 70^\circ}{11.93} = \frac{\sin A}{12}$$

$$A = 70.9^\circ$$

The Bearing of ship *C* from Ship *A* is $30^\circ + 70.9^\circ = 100.9^\circ$

Find the bearing of *C* from *A*. First calculate the angle

$\angle BAC$ ($= A$) . Use $\frac{\sin B}{b} = \frac{\sin A}{a}$, where $B = 70^\circ$,

$$b = x = 11.93 \text{ (km) } , a = 12 \text{ (km) }$$

Solutionbank C1

Edexcel Modular Mathematics for AS and A-Level

Algebra and functions

Exercise A, Question 23

Question:

(a) Express $\log_p 12 - \left(\frac{1}{2} \log_p 9 + \frac{1}{3} \log_p 8 \right)$ as a single logarithm to base p .

(b) Find the value of x in $\log_4 x = -1.5$

Solution:

$$(a) \log_p 12 - \frac{1}{2} \left(\log_p 9 + \frac{2}{3} \log_p 8 \right)$$

$$= \log_p 12 - \frac{1}{2} \left(\log_p 9 + \log_p \left(8^{2/3} \right) \right) \quad \text{Use the power law: } \log_a (x^k) = k \log_a x, \text{ so that}$$

$$= \log_p 12 - \frac{1}{2} \left(\log_p 9 + \log_p 4 \right) \quad 8^{2/3} = \left(8^{1/3} \right)^2 = 2^2 = 4$$

$$= \log_p 12 - \frac{1}{2} \log_p 36$$

Use the multiplication law: $\log_a (xy) = \log_a x + \log_a y$, so that $\log_p 9 + \log_p 4 = \log_p (9 \times 4) = \log_p 36$

$$= \log_p 12 - \log_p \left(36^{1/2} \right)$$

Use the power law: $\log_a (x^k) = k \log_a x$, so that

$$\frac{1}{2} \log_p 36 = \log_p \left(36^{1/2} \right) = \log_p 6$$

$$= \log_p 12 - \log_p 6$$

Use the division law: $\log_a \left(\frac{x}{y} \right) = \log_a x - \log_a y$, so that

$$= \log_p \left(\frac{12}{6} \right)$$

$$\log_p 12 - \log_p 6 = \log_p \left(\frac{12}{6} \right) = \log_p 2$$

$$= \log_p 2$$

(b) $\log_4 x = -1.5$

$$\frac{\log_{10} x}{\log_{10} 4} = -1.5$$

Change the base of the logarithm. Use $\log_a x = \frac{\log_{10} x}{\log_{10} a}$, so that

$$\log_4 x = \frac{\log_{10} x}{\log_{10} 4}$$

$$\log_{10} x = -1.5 \log_{10} 4$$

Multiply throughout by $\log_{10} 4$

$$x = 10^{-1.5 \log_{10} 4}$$

$\log_a n = x$ means $a^x = n$, so $\log_{10} x = c$ means $x = 10^c$, where

$$= 0.125$$

$$c = -1.5 \log_{10} 4.$$

Solutionbank C1

Edexcel Modular Mathematics for AS and A-Level

Algebra and functions

Exercise A, Question 24

Question:

The point $P(4, -2)$ lies on a circle, centre $C(1, 5)$.

- (a) Find an equation for the circle.
 (b) Find an equation for the tangent to the circle at P .

Solution:

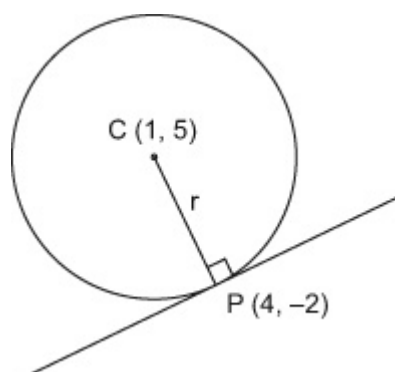

Draw a diagram using the given information

Let $CP = r$

(a)

$$(x - 1)^2 + (y - 5)^2 = r^2$$

$$\begin{aligned} r &= \sqrt{(4 - 1)^2 + (-2 - 5)^2} \\ &= \sqrt{3^2 + (-7)^2} \\ &= \sqrt{9 + 49} \\ &= \sqrt{58} \end{aligned}$$

The equation of the circle is

$$\begin{aligned} (x - 1)^2 + (y - 5)^2 &= (\sqrt{58})^2 \\ (x - 1)^2 + (y - 5)^2 &= 58 \end{aligned}$$

(b)

The gradient of CP is $\frac{-2-5}{4-1} = \frac{-7}{3}$

So the gradient of the tangent is $\frac{3}{7}$

The equation of the tangent at P is

Use $(x - a)^2 + (y - b)^2 = r^2$ where (a, b) is the centre of the circle. Here $(a, b) = (1, 5)$.

Use $d = \sqrt{(x_2 - x_1)^2 + (y_2 - y_1)^2}$ where $(x_1, y_1) = (1, 5)$ and $(x_2, y_2) = (4, -2)$.

Use $\frac{y_2 - y_1}{x_2 - x_1}$, where $(x_1, y_1) = (1, 5)$ and $(x_2, y_2) = (4, -2)$.

The tangent at P is perpendicular to the gradient at P. Use $\frac{-1}{m}$. Here $m = -\frac{7}{3}$ so $\frac{-1}{(-\frac{7}{3})} = \frac{3}{7}$

Use $y - y_1 = m(x - x_1)$, where $(x_1, y_1) = (4, -$

$$y + 2 = \frac{3}{7} (x - 4)$$

$$2) \text{ and } m = \frac{3}{7}.$$

© Pearson Education Ltd 2008

Solutionbank C1

Edexcel Modular Mathematics for AS and A-Level

Algebra and functions

Exercise A, Question 25

Question:

The remainder when $x^3 - 2x + a$ is divided by $(x - 1)$ is equal to the remainder when $2x^3 + x - a$ is divided by $(2x + 1)$. Find the value of a .

Solution:

$$f(x) = x^3 - 2x + a$$

$$g(x) = 2x^3 + x - a$$

$$f(1) = g\left(-\frac{1}{2}\right)$$

Use the remainder theorem: If $f(x)$ is divided by $ax - b$, then the remainder is $f\left(\frac{b}{a}\right)$. Compare $(x - 1)$ to $ax - b$, so $a = 1$, $b = 1$ and the remainder is $f(1)$.

Use the remainder theorem: If $g(x)$ is divided by $ax - b$, then the remainder is $g\left(\frac{b}{a}\right)$. Compare $(2x + 1)$ to $ax - b$, so $a = 2$, $b = -1$ and the remainder is $g\left(-\frac{1}{2}\right)$.

The remainders are equal so $f(1) = g\left(-\frac{1}{2}\right)$.

$$(1)^3 - 2(1) + a = 2\left(-\frac{1}{2}\right)$$

$$3 + \left(-\frac{1}{2}\right) - a$$

$$1 - 2 + a = -\frac{1}{4} - \frac{1}{2} - a$$

$$\left(-\frac{1}{2}\right)^3 = \frac{-1}{8}$$

$$2a = \frac{1}{4}$$

$$2 \times -\frac{1}{8} = -\frac{1}{4}$$

$$\text{so } a = \frac{1}{8}.$$

Solutionbank C1

Edexcel Modular Mathematics for AS and A-Level

Algebra and functions

Exercise A, Question 26

Question:

The diagram shows $\triangle ABC$.
Calculate the area of $\triangle ABC$.

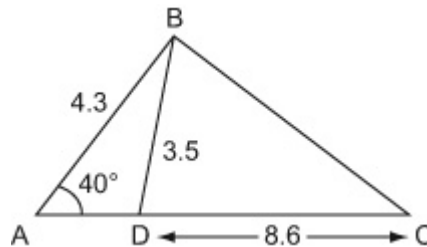

Solution:

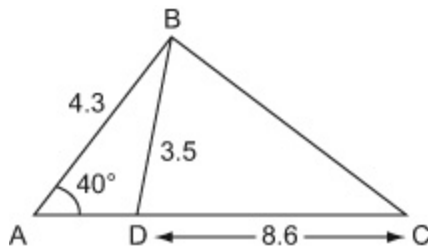

$$\frac{\sin \angle BDA}{4.3} = \frac{\sin 40^\circ}{3.5}$$

$$\sin \angle BDA = \frac{4.3 \sin 40^\circ}{3.5}$$

$$\angle BDA = 52.16^\circ$$

$$\angle ABD = 180^\circ - (52.16^\circ + 40^\circ)$$

$$= 87.84^\circ$$

$$\frac{AD}{\sin 87.84^\circ} = \frac{3.5}{\sin 40^\circ}$$

$$AD = \frac{3.5 \sin 87.84^\circ}{\sin 40^\circ}$$

$$= 5.44 \text{ cm}$$

$$AC = AD + DC = 5.44 + 8.6$$

$$= 14.04$$

$$\text{Area of } \triangle ABC = \frac{1}{2} \times 4.3 \times 14.04 \times \sin 40^\circ$$

$$= 19.4 \text{ cm}^2$$

In $\triangle ABD$, use $\frac{\sin D}{d} = \frac{\sin A}{a}$, where

$D = \angle BDA$, $d = 4.3$, $A = 40^\circ$, $a = 3.5$.

Angles in a triangle sum to 180° .

In $\triangle ABD$, use $\frac{b}{\sin B} = \frac{a}{\sin A}$, where

$b = AD$, $B = 87.84^\circ$, $a = 3.5$, $A = 40^\circ$.

In $\triangle ABC$, use Area = $\frac{1}{2} bc \sin A$ where

$b = 14.04$, $c = 4.3$, $A = 40^\circ$.

Solutionbank C1

Edexcel Modular Mathematics for AS and A-Level

Algebra and functions

Exercise A, Question 27

Question:

Solve $3^{2x+1} + 5 = 16(3^x)$.

Solution:

$$3^{2x+1} + 5 = 16(3^x)$$

$$3(3^{2x}) + 5 = 16(3^x)$$

$$3(3^x)^2 + 5 = 16(3^x)$$

$$\text{let } y = 3^x$$

$$\text{so } 3y^2 + 5 = 16y$$

$$3y^2 - 16y + 5 = 0$$

$$(3y - 1)(y - 5) = 0$$

$$y = \frac{1}{3}, \quad y = 5$$

$$\text{Now } 3^x = \frac{1}{3}, \text{ so } x = -1.$$

$$\text{and } 3^x = 5,$$

$$\log_{10}(3^x) = \log_{10}5$$

$$x \log_{10}3 = \log_{10}5$$

$$x = \frac{\log_{10}5}{\log_{10}3}$$

$$= 1.46$$

$$\text{so } x = -1 \text{ and } x = 1.46$$

Use the rules for indices: $a^m \times a^n = a^{m+n}$, so that

$$3^{2x+1} = 3^{2x} \times 3^1$$

$$= 3(3^{2x}).$$

Also, $(a^m)^n = a^{mn}$, so that $3^{2x} = (3^x)^2$.

Factorise $3y^2 - 16y + 5 = 0$. $ac = 15$ and $(-15) + (-1) = -16$, so that

$$3y^2 - 16y + 5 = 3y^2 - 15y - y + 5$$

$$= 3y(y - 5) - 1(y - 5)$$

$$= (y - 5)(3y - 1)$$

Take logarithm to base 10 of each side.

Use the power law: $\log_a(x^K) = K \log_a x$, so that

$$\log_{10}(3^x) = x \log_{10}3$$

Divide throughout by $\log_{10}3$

Solutionbank C1

Edexcel Modular Mathematics for AS and A-Level

Algebra and functions

Exercise A, Question 28

Question:

The coordinates of the vertices of $\triangle ABC$ are $A(2, 5)$, $B(0, 2)$ and $C(4, 0)$.

Find the value of $\cos \angle ABC$.

Solution:

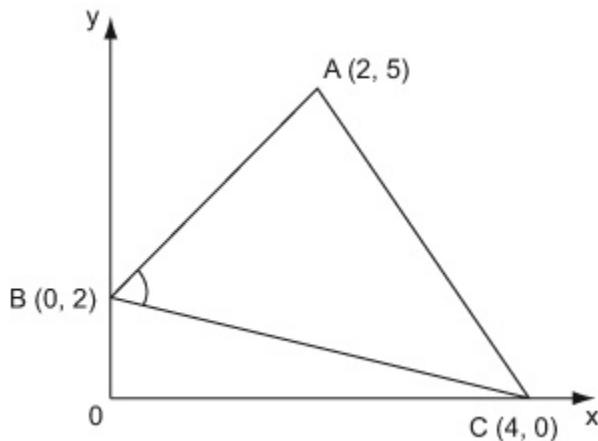

Draw a diagram using the given information.

$$\begin{aligned} AB^2 &= (2 - 0)^2 + (5 - 2)^2 \\ &= 2^2 + 3^2 \\ &= 4 + 9 \\ &= 13 \end{aligned}$$

Use $d^2 = (x_2 - x_1)^2 + (y_2 - y_1)^2$, with
 $(x_1, y_1) = (0, 2)$ and $(x_2, y_2) = (2, 5)$.

$$\begin{aligned} BC^2 &= (0 - 4)^2 + (2 - 0)^2 \\ &= (-4)^2 + (2)^2 \\ &= 16 + 4 \\ &= 20 \end{aligned}$$

Use $d^2 = (x_2 - x_1)^2 + (y_2 - y_1)^2$ with
 $(x_1, y_1) = (4, 0)$ and $(x_2, y_2) = (0, 2)$.

$$\begin{aligned} CA^2 &= (4 - 2)^2 + (0 - 5)^2 \\ &= 2^2 + (-5)^2 \\ &= 4 + 25 \\ &= 29 \end{aligned}$$

Use $d^2 = (x_2 - x_1)^2 + (y_2 - y_1)^2$ with
 $(x_1, y_1) = (2, 5)$ and $(x_2, y_2) = (4, 0)$.

$$\begin{aligned} \cos \angle ABC &= \frac{AB^2 + BC^2 - AC^2}{2 \times AB \times BC} \\ &= \frac{13 + 20 - 29}{2\sqrt{13}\sqrt{20}} \end{aligned}$$

Use $\cos B = \frac{a^2 + c^2 - b^2}{2ac}$, where $B = \angle ABC$,
 $a = BC$, $c = AB$, $b = AC$

$$\angle ABC = 82.9^\circ$$

Solutionbank C1

Edexcel Modular Mathematics for AS and A-Level

Algebra and functions

Exercise A, Question 29

Question:

Solve the simultaneous equations

$$4 \log_9 x + 4 \log_3 y = 9$$

$$6 \log_3 x + 6 \log_{27} y = 7$$

Solution:

$$4 \log_9 x + 4 \log_3 y = 9$$

$$4 \frac{\log_3 x}{\log_3 9} + 4 \log_3 y = 9$$

$$2 \log_3 x + 4 \log_3 y = 9 \quad \textcircled{1}$$

$$6 \log_3 x + 6 \log_{27} y = 7$$

$$6 \log_3 x + \frac{6 \log_3 y}{\log_3 27} = 7$$

$$6 \log_3 x + 2 \log_3 y = 7 \quad \textcircled{2}$$

Solve ① & ② simultaneously.

Let $\log_3 x = X$ and $\log_3 y = Y$

$$\text{so } 2X + 4Y = 9$$

$$6X + 2Y = 7$$

$$6X + 12Y = 27$$

$$-6X + 2Y = 7$$

$$10Y = 20$$

$$Y = 2$$

Sub $Y = 2$ into $2X + 4Y = 9$

Change the base of the logarithm, use $\log_a x = \frac{\log_b x}{\log_b a}$, so

$$\text{that } \log_9 x = \frac{\log_3 x}{\log_3 9}.$$

$$\begin{aligned} \log_3 9 &= \log_3 (3^2) \\ &= 2 \log_3 3 = 2 \times 1 = 2 \end{aligned}$$

$$\frac{4 \log_3 x}{\log_3 9} = \frac{4 \log_3 x}{2} = 2 \log_3 x$$

Change the base of the logarithm, use $\log_a x = \frac{\log_b x}{\log_b a}$, so

$$\text{that } \log_{27} y = \frac{\log_3 y}{\log_3 27}$$

$$\begin{aligned} \log_3 27 &= \log_3 (3^3) \\ &= 3 \log_3 3 \\ &= 3 \times 1 = 3 \end{aligned}$$

$$\begin{aligned} \text{so } \frac{6 \log_3 y}{\log_3 27} &= \frac{6 \log_3 y}{3} \\ &= 2 \log_3 y \end{aligned}$$

Multiply ① throughout by 3

$$2X + 4(2) = 9$$

$$2X + 8 = 9$$

$$2X = 1$$

$$X = \frac{1}{2}$$

Check sub X =

$$\frac{1}{2} \text{ and } Y = 2 \text{ into } 6x + 2y = 7$$

$$6\left(\frac{1}{2}\right) + 2(2)$$

$$= 3 + 4 = 7 \checkmark \checkmark \text{ (correct)}$$

so $(X =) \log_3 x = \frac{1}{2}$

i.e. $x = 3^{1/2}$

$$\log_a n = x \text{ means } a^x = n, \text{ so } \log_3 x = \frac{1}{2} \text{ means } x = 3^{1/2}.$$

and $(Y =) \log_3 y = 2$

i.e. $y = 3^2 = 9$

$$\log_a n = x \text{ means } a^x = n, \text{ so } \log_3 y = 2 \text{ means } y = 3^2$$

so $(x, y) = (3^{1/2}, 9)$

Solutionbank C1

Edexcel Modular Mathematics for AS and A-Level

Algebra and functions

Exercise A, Question 30

Question:

The line $y = 5x - 13$ meets the circle $(x - 2)^2 + (y + 3)^2 = 26$ at the points A and B .

(a) Find the coordinates of the points A and B .

M is the midpoint of the line AB .

(b) Find the equation of the line which passes through M and is perpendicular to the line AB . Write your answer in the form $ax + by + c = 0$, where a , b and c are integers.

Solution:

(a)

$$y = 5x - 13$$

$$(x - 2)^2 + (y + 3)^2 = 26$$

$$(x - 2)^2 + (5x - 13 + 3)^2 = 26$$

$$(x - 2)^2 + (5x - 10)^2 = 26$$

$$x^2 - 4x + 4 + 25x^2 - 100x + 100 = 26$$

$$26x^2 - 104x + 78 = 0 \quad \text{Divide throughout by 26}$$

$$x^2 - 4x + 3 = 0 \quad \text{Factorise } x^2 - 4x + 3.$$

$$(x - 3)$$

$$(x - 1) = 0$$

$$x = 3, x = 1$$

$$\text{When } x = 1, y = 5(1) - 13$$

$$= 5 - 13$$

$$= -8$$

$$\text{When } x = 3, y = 5(3) - 13$$

$$= 15 - 13$$

$$= 2$$

So the coordinates of the points of intersection are $(1, -8)$ and $(3, 2)$.

(b)

$$\text{The Midpoint of } AB \text{ is } \left(\frac{1+3}{2}, \frac{-8+2}{2} \right) = (2, -3).$$

Solve the equations simultaneously. Substitute $y = 5x - 13$ into $(x - 2)^2 + (y + 3)^2 = 26$.

Expand and Simplify

$$(-3) \times (-1) = +3$$

$$(-3) + (-1) = -4$$

$$\text{so } x^2 - 4x + 3 = (x - 3)(x - 1)$$

Find the Corresponding y coordinates. Substitute $x = 1$ into $y = 5x - 13$.

Substitute $x = 3$ into $y = 5x - 13$

$$\text{Use } \left(\frac{x_1 + x_2}{2}, \frac{y_1 + y_2}{2} \right) \text{ with } (x_1, y_1) = (1, -8) \text{ and } (x_2, y_2) = (3, 2)$$

The gradient of the line perpendicular to $y = 5x - 13$ is $-\frac{1}{5}$

$$\text{so, } y + 3 = \frac{-1}{5} (x - 2)$$

$$5y + 15 = -1 (x - 2)$$

$$5y + 15 = -x + 2$$

$$x + 5y + 13 = 0$$

The gradient of the line perpendicular to $y = mx + c$ is $-\frac{1}{m}$. Here $m = 5$.

Use $y - y_1 = m (x - x_1)$ with $m = \frac{-1}{5}$ and $(x_1, y_1) = (2, -3)$

Clear the fraction. Multiply each side by 5.

Solutionbank C1

Edexcel Modular Mathematics for AS and A-Level

Algebra and functions

Exercise A, Question 31

Question:

The circle C has equation $x^2 + y^2 - 10x + 4y + 20 = 0$.
Find the length of the tangent to C from the point $(-4, 4)$.

Solution:

The angle between a tangent and a radius is a right-angle, so form a right-angled triangle with the tangent, the radius and the distance between the centre of the circle and the point $(-4, 4)$.

$$x^2 + y^2 - 10x + 4y + 20 = 0$$

$$(x - 5)^2 - 25 + (y + 2)^2 - 4 = -20$$

$$(x - 5)^2 + (y + 2)^2 = 9$$

So circle has centre $(5, -2)$ and radius 3

$$\begin{aligned} &\sqrt{(5 - (-4))^2 + (-2 - 4)^2} \\ &= \sqrt{81 + 36} = \sqrt{117} \end{aligned}$$

$$\text{Therefore } 117 = 3^2 + x^2$$

$$x^2 = 108$$

$$x = \sqrt{108}$$

Find the equation of the tangent in the form $(x - a)^2 + (y - b)^2 = r^2$

Calculate the distance between the centre of the circle and $(-4, 4)$

Using Pythagoras

Solutionbank C2

Edexcel Modular Mathematics for AS and A-Level

Revision Exercises 2

Exercise A, Question 1

Question:

Expand and simplify $(1 - x)^5$.

Solution:

$$\begin{aligned}(1 - x)^5 &= 1 + 5(-x) + 10(-x)^2 + 10(-x)^3 \\ &\quad + 5(-x)^4 + (-x)^5 \\ &= 1 - 5x + 10x^2 - 10x^3 + 5x^4 - x^5\end{aligned}$$

Compare $(1 + x)^n$ with $(1 - x)^n$. Replace n by 5 and 'x' by $-x$.

Solutionbank C2

Edexcel Modular Mathematics for AS and A-Level

Revision Exercises 2

Exercise A, Question 2

Question:

In the diagram, ABC is an equilateral triangle with side 8 cm. PQ is an arc of a circle centre A, radius 6 cm. Find the perimeter of the shaded region in the diagram.

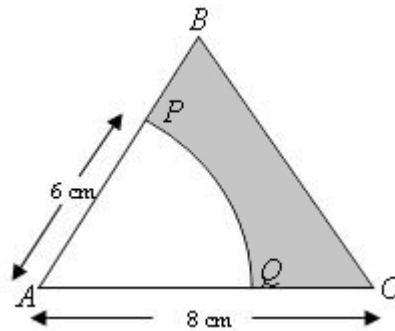

Solution:

Remember: The length of an arc of a circle is $L = r\theta$.

The area of a sector is $A = \frac{1}{2}r^2\theta$.

Draw a diagram. Remember: $60^\circ = \frac{\pi}{3}$ radians

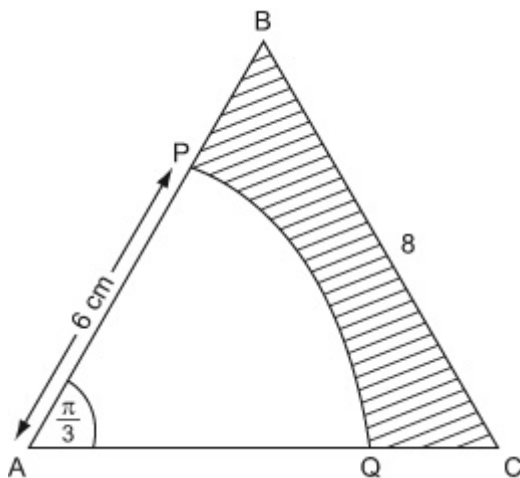

Length of arc $PQ = r\theta$

$$= 6 \left(\frac{\pi}{3} \right)$$

$$= 2\pi \text{ cm}$$

Perimeter of shaded region

$$= 2 + 8 + 2 + 2\pi$$

$$= 12 + 2\pi$$

$$= 18.28 \text{ cm}$$

Solutionbank C2

Edexcel Modular Mathematics for AS and A-Level

Revision Exercises 2

Exercise A, Question 3

Question:

The sum to infinity of a geometric series is 15. Given that the first term is 5,

- (a) find the common ratio,
 (b) find the third term.

Solution:

(a)

$$\frac{a}{1-r} = 15, \quad a = 5$$

$$\frac{5}{1-r} = 15$$

$$1-r = \frac{1}{3}$$

$$r = \frac{2}{3}$$

Remember: $s_{\infty} = \frac{a}{1-r}$, where $|r| < 1$. Here $s_{\infty} = 15$ and $a = 5$ so that $15 = \frac{5}{1-r}$.

(b)

$$ar^2 = 5 \left(\frac{2}{3} \right)^2$$

$$= 5 \times \frac{4}{9}$$

$$= \frac{20}{9}$$

Remember: n th term = ar^{n-1} . Here $a = 5$, $r = \frac{2}{3}$ and $n = 3$, so that

$$ar^{n-1} = 5 \left(\frac{2}{3} \right)^{3-1}$$

$$= 5 \left(\frac{2}{3} \right)^2$$

Solutionbank C2

Edexcel Modular Mathematics for AS and A-Level

Revision Exercises 2

Exercise A, Question 4

Question:

Sketch the graph of $y = \sin \theta^\circ$ in the interval $-\frac{3\pi}{2} \leq \theta < \pi$.

Solution:

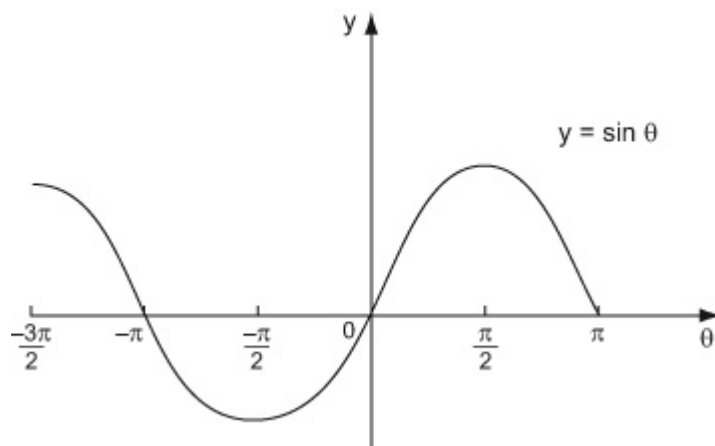

Remember: $180^\circ = \pi$ radians

Solutionbank C2

Edexcel Modular Mathematics for AS and A-Level

Revision Exercises 2

Exercise A, Question 5

Question:

Find the first three terms, in descending powers of b , of the binomial expansion of $(2a + 3b)^6$, giving each term in its simplest form.

Solution:

$$\begin{aligned} (2a + 3b)^6 &= (2a)^6 + \binom{6}{1} (2a)^5 (3b) + \binom{6}{2} \\ & (2a)^4 (3b)^2 + \dots \\ &= 2^6 a^6 + 6 \times 2^5 \times 3 \times a^5 b + 15 \times 2^4 \times 3^2 \times a^4 b^2 + \dots \\ &= 64a^6 + 576a^5b + 2160a^4b^2 + \dots \end{aligned}$$

Compare $(2a + 3b)^n$ with $(a + b)^n$. Replace n by 6, 'a' by $2a$ and 'b' by $3b$.

Solutionbank C2

Edexcel Modular Mathematics for AS and A-Level

Revision Exercises 2

Exercise A, Question 6

Question:

AB is an arc of a circle centre O . Arc $AB = 8$ cm and $OA = OB = 12$ cm.

(a) Find, in radians, $\angle AOB$.

(b) Calculate the length of the chord AB , giving your answer to 3 significant figures.

Solution:

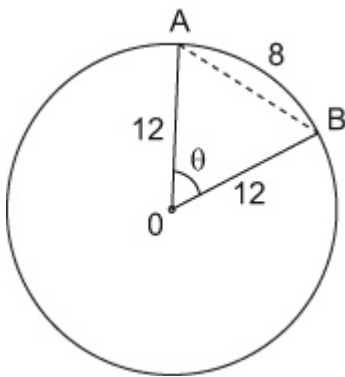

Draw a diagram. Let $\angle AOB = \theta$.

(a)

$$\angle AOB = \theta$$

$$12\theta = 8$$

$$\text{so } \theta = \frac{2}{3}$$

Use $l = r\theta$. Here $l = 8$ and $r = 12$.

(b)

$$AB^2 = 12^2 + 12^2 - 2(12)(12)\cos\left(\frac{2}{3}\right)$$

$$= 61.66 \dots$$

$$AB = 7.85 \text{ cm (3 s.f.)}$$

Use the cosine formula $c^2 = a^2 + b^2 - 2ab \cos C$. Here $c = AB$, $a = 12$, $b = 12$ and $C = \theta = \frac{2}{3}$. Remember to change your to radians.

Solutionbank C2

Edexcel Modular Mathematics for AS and A-Level

Revision Exercises 2

Exercise A, Question 7

Question:

A geometric series has first term 4 and common ratio r . The sum of the first three terms of the series is 7.

(a) Show that $4r^2 + 4r - 3 = 0$.

(b) Find the two possible values of r .

Given that r is positive,

(c) find the sum to infinity of the series.

Solution:

(a)

$$4, 4r, 4r^2, \dots$$

$$4 + 4r + 4r^2 = 7$$

$$4r^2 + 4r - 3 = 0 \text{ (as required)}$$

Use ar^{n-1} to write down expressions for the first 3 terms.
Here $a = 4$ and $n = 1, 2, 3$.

(b)

$$4r^2 + 4r - 3 = 0$$

$$(2r - 1)(2r + 3) = 0$$

$$r = \frac{1}{2}, r = \frac{-3}{2}$$

Factorize $4r^2 + 4r - 3$. $ac = -12$. $(-2) + (+6) = +4$, so

$$\begin{aligned} 4r^2 - 2r + 6r - 3 &= 2r(2r - 1) + 3(2r - 1) \\ &= (2r - 1)(2r + 3) \end{aligned}$$

(c)

$$r = \frac{1}{2}$$

$$\frac{a}{1-r} = \frac{4}{1-\frac{1}{2}} = 8$$

Use $S_{\infty} = \frac{a}{1-r}$. Here $a = 4$ and $r = \frac{1}{2}$, so that

$$\frac{a}{1-r} = \frac{4}{1-\frac{1}{2}}$$

$$= \frac{4}{\frac{1}{2}}$$

$$= 8.$$

Solutionbank C2

Edexcel Modular Mathematics for AS and A-Level

Revision Exercises 2

Exercise A, Question 8

Question:

- (a) Write down the number of cycles of the graph $y = \sin nx$ in the interval $0 \leq x \leq 360^\circ$.
- (b) Hence write down the period of the graph $y = \sin nx$.

Solution:

- (a)
 n

Consider the graphs of $y = \sin x$, $y = \sin 2x$, $y = \sin 3x \dots$

$y = \sin x$ has 1 cycle in the interval $0 \leq x \leq 360^\circ$.

$y = \sin 2x$ has 2 cycles in the interval $0 \leq x \leq 360^\circ$.

$y = \sin 3x$ has 3 cycles in the interval $0 \leq x \leq 360^\circ$.

etc.

So $y = \sin nx$ has n cycles in the interval $0 \leq x \leq 360^\circ$.

- (b)

$$\frac{360^\circ}{n} \quad \left(\text{or } \frac{2\pi}{n} \right)$$

Period = length of cycle. If there are n cycles in the interval $0 \leq x \leq 360^\circ$, the length of each cycle will be $\frac{360^\circ}{n}$.

Solutionbank C2

Edexcel Modular Mathematics for AS and A-Level

Revision Exercises 2

Exercise A, Question 9

Question:

(a) Find the first four terms, in ascending powers of x , of the binomial expansion of $(1 + px)^7$, where p is a non-zero constant.

Given that, in this expansion, the coefficients of x and x^2 are equal,

(b) find the value of p ,

(c) find the coefficient of x^3 .

Solution:

(a)

$$\begin{aligned} (1 + px)^7 &= 1 + nx + \frac{n(n-1)}{2!}x^2 + \frac{n(n-1)(n-2)}{3!}x^3 + \dots \\ &= 1 + 7(px) + \frac{7(6)}{2!}(px)^2 + \frac{7(6)(5)}{3!}(px)^3 + \dots \\ &= 1 + 7px + 21p^2x^2 + 35p^3x^3 + \dots \end{aligned}$$

Compare $(1 + x)^n$ with $(1 + px)^n$.
Replace n by 7 and 'x' by px .

(b)

$$\begin{aligned} 7p &= 21p^2 \\ p \neq 0, \text{ so } 7 &= 21p \\ p &= \frac{1}{3} \end{aligned}$$

The coefficients of x and x^2 are equal, so
 $7p = 21p^2$.

(c)

$$35p^3 = 35 \left(\frac{1}{3}\right)^3 = \frac{35}{27}$$

The coefficient of x^3 is $35p^3$. Here $p = \frac{1}{3}$, so that $35p^3 = 35 \left(\frac{1}{3}\right)^3$.

Solutionbank C2

Edexcel Modular Mathematics for AS and A-Level

Revision Exercises 2

Exercise A, Question 10

Question:

A sector of a circle of radius 8 cm contains an angle of θ radians. Given that the perimeter of the sector is 30 cm, find the area of the sector.

Solution:

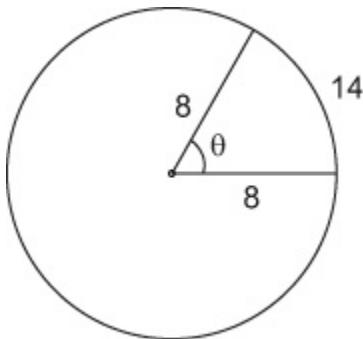

Draw a diagram. Perimeter of sector = 30cm, so arc length = 14 cm.

$$8\theta = 14$$

$$\theta = \frac{14}{8}$$

Find the value of θ . Use $L = r\theta$. Here $L = 14$ and $r = 8$ so that $8\theta = 14$.

$$\text{Area of sector} = \frac{1}{2} (8)^2 \theta$$

$$= \frac{1}{2} (8)^2 \left(\frac{14}{8} \right)$$

$$= 56 \text{ cm}^2$$

Use $A = \frac{1}{2} r^2 \theta$. Here $r = 8$ and $\theta = \frac{14}{8}$, so that $A = \frac{1}{2} (8)$

$$^2 \left(\frac{14}{8} \right) .$$

Solutionbank C2

Edexcel Modular Mathematics for AS and A-Level

Revision Exercises 2

Exercise A, Question 11

Question:

A pendulum is set swinging. Its first oscillation is through 30° . Each succeeding oscillation is $\frac{9}{10}$ of the one before it. What is the total angle described by the pendulum before it stops?

Solution:

$$30, \quad 30 \left(\frac{9}{10} \right), \quad 30 \left(\frac{9}{10} \right)^2, \quad \dots$$

$$\begin{aligned} \frac{a}{1-r} &= \frac{30}{1 - \frac{9}{10}} \\ &= \frac{30}{\left(\frac{1}{10} \right)} \\ &= 300^\circ \end{aligned}$$

Write down the first 3 term. Use ar^{n-1} . Here $a = 30$, $r = \frac{9}{10}$ and $n = 1, 2, 3$.

$$\begin{aligned} \text{Use } S_\infty &= \frac{a}{1-r}. \text{ Here } a = 30 \text{ and } r = \frac{9}{10} \text{ so that } S_\infty = \\ &= \frac{30}{1 - \frac{9}{10}}. \end{aligned}$$

Solutionbank C2

Edexcel Modular Mathematics for AS and A-Level

Revision Exercises 2

Exercise A, Question 12

Question:

Write down the exact value

(a) $\sin 30^\circ$, (b) $\cos 330^\circ$, (c) $\tan(-60^\circ)$.

Solution:

(a)

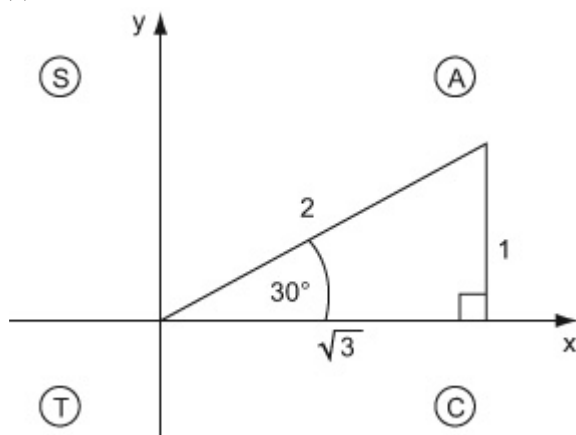

Draw a diagram for each part. Remember

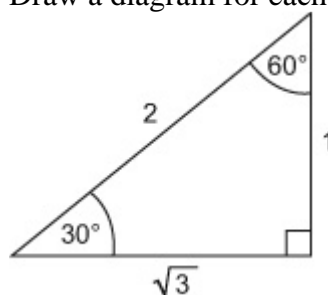

$$\sin 30^\circ = \frac{1}{2}$$

(b)

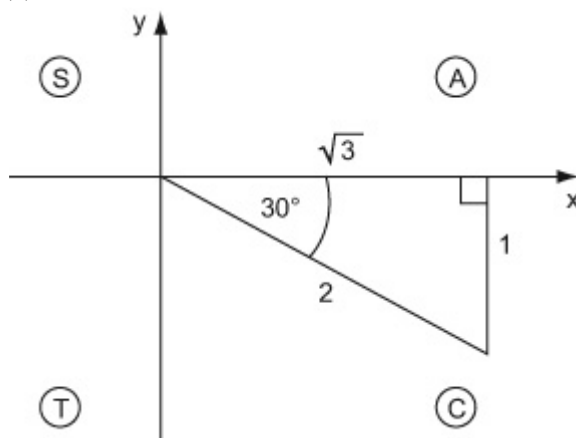

$$\cos 330^\circ = \cos 30^\circ = \frac{\sqrt{3}}{2}$$

330° is in the fourth quadrant.

(c)

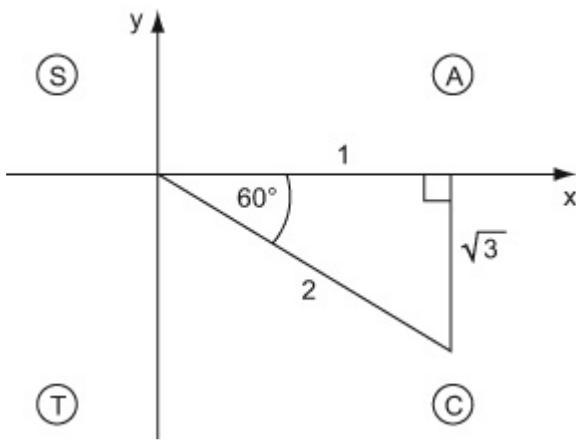

$$\begin{aligned}\tan (-60^\circ) &= -\tan 60^\circ \\ &= -\frac{\sqrt{3}}{1} \\ &= -\sqrt{3}\end{aligned}$$

-60° is in the fourth quadrant.

Solutionbank C2

Edexcel Modular Mathematics for AS and A-Level

Revision Exercises 2

Exercise A, Question 13

Question:

(a) Find the first three terms, in ascending powers of x , of the binomial expansion of $(1 - ax)^8$, where a is a non-zero integer.

The first three terms are 1 , $-24x$ and bx^2 , where b is a constant.

(b) Find the value of a and the value of b .

Solution:

(a)

$$\begin{aligned} (1 - ax)^8 &= 1 + nx + \frac{n(n-1)}{2!}x^2 + \dots \\ &= 1 + 8(-ax) + \frac{8(8-1)}{2!} \\ &\quad (-ax)^2 + \dots \\ &= 1 - 8ax + 28a^2x^2 + \dots \end{aligned}$$

Compare $(1 + x)^n$ with $(1 - ax)^n$ Replace n by 8 and 'x' by $-ax$.

(b)

$$\begin{aligned} -8a &= -24 \\ a &= 3 \\ b &= 28a^2 \\ &= 28(3)^2 \\ &= 252 \end{aligned}$$

Compare coefficients of x , so that $-8a = -24$.

so $a = 3$ and $b = 252$

Solutionbank C2

Edexcel Modular Mathematics for AS and A-Level

Revision Exercises 2

Exercise A, Question 14

Question:

In the diagram, A and B are points on the circumference of a circle centre O and radius 5 cm.

$$\angle AOB = \theta \text{ radians.}$$

$$AB = 6 \text{ cm.}$$

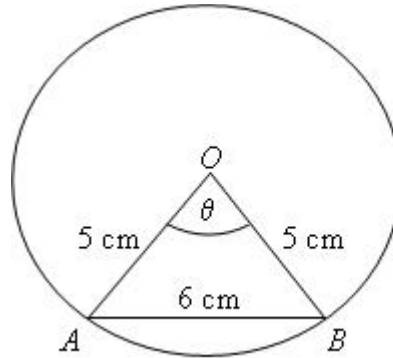

(a) Find the value of θ .

(b) Calculate the length of the minor arc AB .

Solution:

(a)

$$\begin{aligned} \cos \theta &= \frac{5^2 + 5^2 - 6^2}{2(5)(5)} \\ &= \frac{7}{25} \end{aligned}$$

$$\theta = 1.287 \text{ radians}$$

Use the cosine formula $\cos C = \frac{a^2 + b^2 - c^2}{2ab}$. Here $c = \theta$,
 $a = 5$, $b = 5$ and $c = 6$.

(b)

$$\begin{aligned} \text{arc } AB &= 5\theta \\ &= 5 \times 1.287 \\ &= 6.44 \text{ cm} \end{aligned}$$

Use $C = r\theta$. Here $C = \text{arc } AB$, $r = 5$ and $\theta = 1.287$ radians.

Solutionbank C2

Edexcel Modular Mathematics for AS and A-Level

Revision Exercises 2

Exercise A, Question 15

Question:

The fifth and sixth terms of a geometric series are 4.5 and 6.75 respectively.

- (a) Find the common ratio.
- (b) Find the first term.
- (c) Find the sum of the first 20 terms, giving your answer to 3 decimal places.

Solution:

(a)

$$ar^4 = 4.5, ar^5 = 6.75$$

$$\frac{ar^5}{ar^4} = \frac{6.75}{4.5}$$

$$r = \frac{3}{2}$$

Find r . Divide ar^5 by ar^4

$$\text{so that } \frac{ar^5}{ar^4} = \frac{ar^{5-4}}{a}$$

$$= r$$

$$\text{and } \frac{6.75}{4.5} = 1.5.$$

(b)

$$a (1.5)^4 = 4.5$$

$$a = \frac{4.5}{(1.5)^4}$$

$$= \frac{8}{9}$$

(c)

$$S_{20} = \frac{\frac{8}{9} ((1.5)^{20} - 1)}{1.5 - 1}$$

$$= 5909.790 \quad (3 \text{ d.p.})$$

Use $S_n = \frac{a(r^n - 1)}{r - 1}$. Here $a = \frac{8}{9}$, $r = 1.5$ and $n = 20$.

Solutionbank C2

Edexcel Modular Mathematics for AS and A-Level

Revision Exercises 2

Exercise A, Question 16

Question:

Given that θ is an acute angle measured in degrees, express in term of $\cos 2\theta$

(a) $\cos (360^\circ + 2\theta)$, (b) $\cos (-2\theta)$, (c) $\cos (180^\circ - 2\theta)$

Solution:

(a)

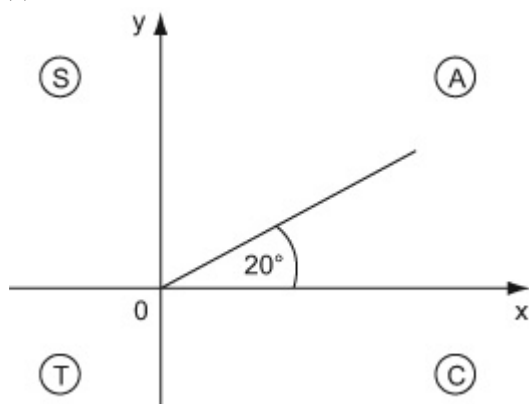

Draw a diagram for each part.

$$\cos (360^\circ + 2\theta) = \cos 2\theta$$

$360^\circ + 2\theta$ is in the first quadrant.

(b)

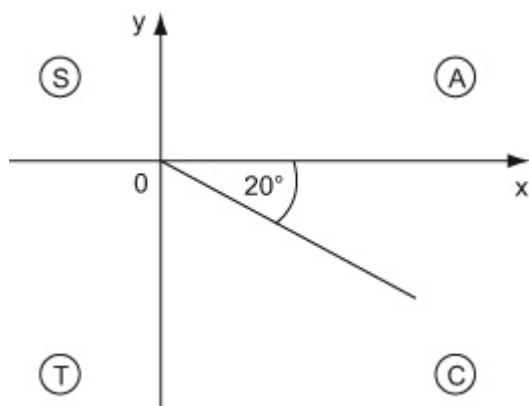

$$\cos (-2\theta) = \cos 2\theta$$

-2θ is in the fourth quadrant.

(c)

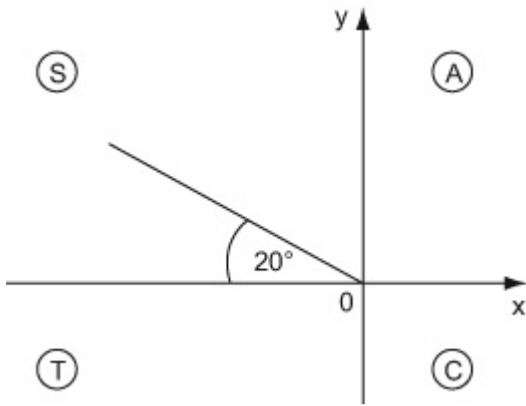

$$\cos (180^\circ - 2\theta) = -\cos 2\theta$$

$180^\circ - 2\theta$ is in the second quadrant.

© Pearson Education Ltd 2008

Solutionbank C2

Edexcel Modular Mathematics for AS and A-Level

Revision Exercises 2

Exercise A, Question 17

Question:

- (a) Expand $(1 - 2x)^{10}$ in ascending powers of x up to and including the term in x^3 .
- (b) Use your answer to part (a) to evaluate $(0.98)^{10}$ correct to 3 decimal places.

Solution:

(a)

$$\begin{aligned} (1 - 2x)^{10} &= 1 + nx + \frac{n(n-1)}{2!}x^2 + \frac{n(n-1)(n-2)}{3!}x^3 + \dots \\ &= 1 + 10(-2x) + \frac{10(9)}{2}(-2x)^2 + \frac{10(9)(8)}{6}(-2x)^3 + \dots \\ &= 1 - 20x + 180x^2 - 960x^3 + \dots \end{aligned}$$

Compare $(1 + x)^n$ with $(1 - 2x)^n$. Replace n by 10 and 'x' by $-2x$.

(b)

$$\begin{aligned} (1 - 2(0.01))^{10} &= 1 - 20(0.01) + 180(0.01)^2 - 960(0.01)^3 + \dots \\ 0.98^{10} &\simeq 0.817 \quad (3 \text{ d.p.}) \end{aligned}$$

Find the value of x .

$$\begin{aligned} 0.98 &= 1 - 0.02 \\ &= 1 - 2(0.01) \end{aligned}$$

Solutionbank C2

Edexcel Modular Mathematics for AS and A-Level

Revision Exercises 2

Exercise A, Question 18

Question:

In the diagram,

$$AB = 10 \text{ cm}, AC = 13 \text{ cm}.$$

$$\angle CAB = 0.6 \text{ radians}.$$

BD is an arc of a circle centre A and radius 10 cm .

(a) Calculate the length of the arc BD .

(b) Calculate the shaded area in the diagram.

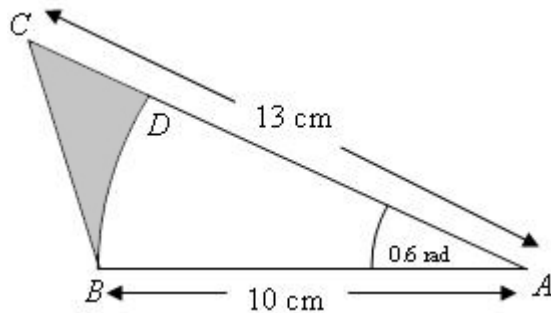

Solution:

(a)

$$\begin{aligned} \text{arc } BD &= 10 \times 0.6 \\ &= 6 \text{ cm} \end{aligned}$$

Use $L = r\theta$. Here $L = \text{arc } BD$, $r = 10$ and $\theta = 0.6$ radians.

(b)

Shaded area

$$\begin{aligned} &= \frac{1}{2} (10) (13) \sin (0.6) - \\ &\frac{1}{2} (10)^2 (0.6) \\ &= 6.70 \text{ cm}^2 (3 \text{ s.f.}) \end{aligned}$$

Use area of triangle $= \frac{1}{2}bc \sin A$ and area of sector $=$

$\frac{1}{2}r^2\theta$. Here $b = 13$, $c = 10$ and $A = (\theta =) 0.6$; $r = 10$ and $\theta = 0.6$.

Solutionbank C2

Edexcel Modular Mathematics for AS and A-Level

Revision Exercises 2

Exercise A, Question 19

Question:

The value of a gold coin in 2000 was £180. The value of the coin increases by 5% per annum.

- (a) Write down an expression for the value of the coin after n years.
- (b) Find the year in which the value of the coin exceeds £360.

Solution:

180, $180(1.05)$, $180(1.05)^2$, ...

Write down the first 3 terms. Use ar^{n-1} . Here $a = 180$, $r = 1.05$ and $n = 1, 2, 3$.

(a)

Value after n years = $180(1.05)^n$

(b)

$180(1.05)^n > 360$

$180(1.05)^{14} = 356.39$

$180(1.05)^{15} = 374.21$

The value of the coin will exceed £360 in 2014.

Substitute values of n . The value of the coin after 14 years is £356.39, and after 15 years is £374.21. So the value of the coin will exceed £360 in the 15th year.

Solutionbank C2

Edexcel Modular Mathematics for AS and A-Level

Revision Exercises 2

Exercise A, Question 20

Question:

Given that x is an acute angle measured in radians, express in terms of $\sin x$

(a) $\sin (2\pi - x)$, (b) $\sin (\pi + x)$, (c) $\cos \left(\frac{\pi}{2} - x \right)$.

Solution:

(a)

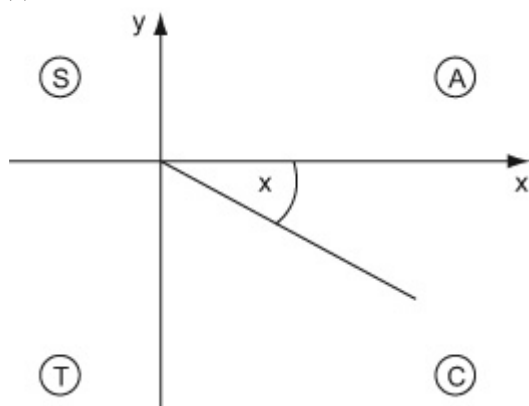

Draw a diagram for each part.

$$\sin (2\pi - x) = -\sin x$$

Remember: π Radians = 180°
 $2\pi - x$ is in the fourth quadrant.

(b)

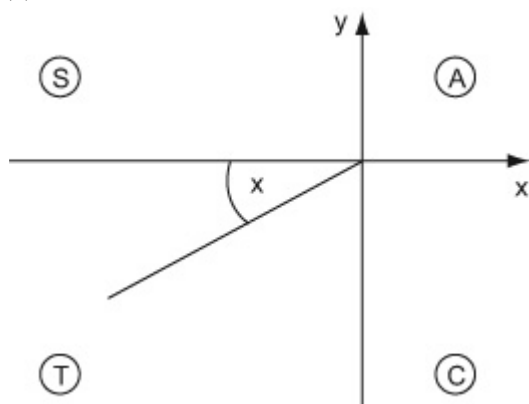

$$\sin (\pi + x) = -\sin x$$

$\pi + x$ is in the third quadrant.

(c)

$$180^\circ = \pi \text{ radians, so } 90^\circ = \frac{\pi}{2} \text{ radians.}$$

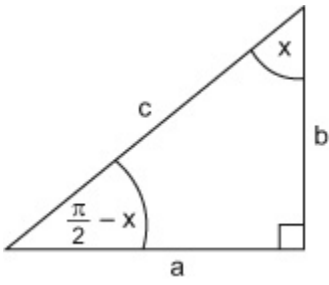

$$\cos \left(\frac{\pi}{2} - x \right) = \sin x \left(= \frac{a}{c} \right) .$$

© Pearson Education Ltd 2008

Solutionbank C2

Edexcel Modular Mathematics for AS and A-Level

Revision Exercises 2

Exercise A, Question 21

Question:

Expand and simplify $\left(x - \frac{1}{x}\right)^6$

Solution:

$$\begin{aligned} \left(x - \frac{1}{x}\right)^6 &= x^6 + \binom{6}{1} x^5 \left(\frac{-1}{x}\right) + \binom{6}{2} x^4 \left(\frac{-1}{x}\right)^2 + \binom{6}{3} x^3 \left(\frac{-1}{x}\right)^3 \\ &\quad + \binom{6}{4} x^2 \left(\frac{-1}{x}\right)^4 + \binom{6}{5} x \left(\frac{-1}{x}\right)^5 + \left(\frac{-1}{x}\right)^6 \\ &= x^6 + 6x^5 \left(\frac{-1}{x}\right) + 15x^4 \left(\frac{1}{x^2}\right) + 20x^3 \left(\frac{-1}{x^3}\right) \\ &\quad + 15x^2 \left(\frac{1}{x^4}\right) + 6x \left(\frac{-1}{x^5}\right) + \frac{1}{x^6} \\ &= x^6 - 6x^4 + 15x^2 - 20 + \frac{15}{x^2} - \frac{6}{x^4} + \frac{1}{x^6} \end{aligned}$$

Compare $\left(x - \frac{1}{x}\right)^n$ with $(a + b)^n$. Replace n by 6, 'a' with x and 'b' with $\frac{-1}{x}$.

$$\binom{6}{2} \left(\frac{-1}{x}\right)^2 = \frac{-1}{x} \times \frac{-1}{x} = \frac{1}{x^2}$$

$$\binom{6}{3} \left(\frac{-1}{x}\right)^3 = \frac{-1}{x} \times \frac{-1}{x} \times \frac{-1}{x} = \frac{-1}{x^3}$$

$$\binom{6}{4} \left(\frac{-1}{x}\right)^4 = \frac{-1}{x} \times \frac{-1}{x} \times \frac{-1}{x} \times \frac{-1}{x} = \frac{1}{x^4}$$

Solutionbank C2

Edexcel Modular Mathematics for AS and A-Level

Revision Exercises 2

Exercise A, Question 22

Question:

A cylindrical log, length 2m, radius 20 cm, floats with its axis horizontal and with its highest point 4 cm above the water level. Find the volume of the log in the water.

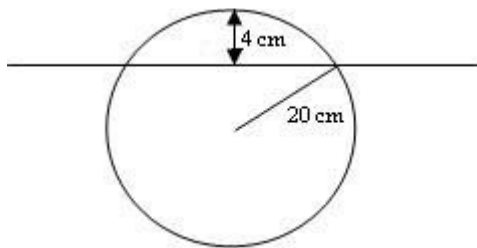

Solution:

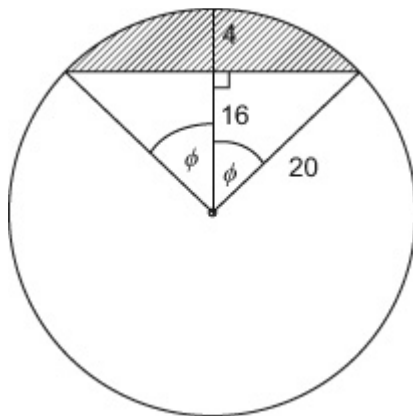

Draw a diagram. Let sector angle = 2ϕ .

$$\cos \phi = \frac{16}{20} \quad (= 0.8)$$

$$\begin{aligned} \text{Area above water level} &= \frac{1}{2}r^2(2\phi) - \frac{1}{2}r^2\sin(2\phi) \\ &= \frac{1}{2}(20)^2(2\phi) - \frac{1}{2} \\ &\quad (20)^2\sin(2\phi) \\ &= 65.40 \text{ cm}^2 \end{aligned}$$

$$\begin{aligned} \text{Use area of segment} &= \frac{1}{2}r^2\theta - \\ &\quad \frac{1}{2}r^2\sin \theta. \text{ Here } r = 20 \text{ cm and} \\ \theta &= 2 \times \cos^{-1}(0.8) \end{aligned}$$

$$\begin{aligned} \text{Area below water level} &= \pi(20)^2 - 65.40 \\ &= 1191.24 \text{ cm}^2 \end{aligned}$$

$$\begin{aligned} \text{Volume below water level} &= 1191.24 \times 200 \\ &= 238248 \text{ cm}^3 \\ &= 0.238 \text{ m}^3 \end{aligned}$$

Solutionbank C2

Edexcel Modular Mathematics for AS and A-Level

Revision Exercises 2

Exercise A, Question 23

Question:

- (a) On the same axes, in the interval $0 \leq x \leq 360^\circ$, sketch the graphs of $y = \tan(x - 90^\circ)$ and $y = \sin x$.
- (b) Hence write down the number of solutions of the equation $\tan(x - 90^\circ) = \sin x$ in the interval $0 \leq x \leq 360^\circ$.

Solution:

(a)

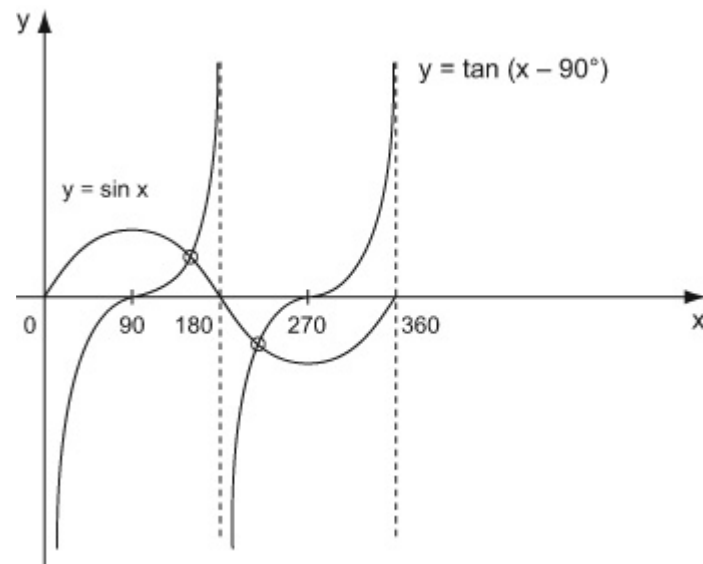

$y = \tan(x - 90^\circ)$ is a translation of $y = \tan x$ by $+90^\circ$ in the x -direction.

(b)

- 2 solutions in the interval $0 \leq x \leq 360$. From the sketch, the graphs of $y = \tan(x - 90^\circ)$ and $y = \sin x$ meet at two points. So there are 2 solutions in the interval $0 \leq x \leq 360^\circ$.

Solutionbank C2

Edexcel Modular Mathematics for AS and A-Level

Revision Exercises 2

Exercise A, Question 24

Question:

A geometric series has first term 4 and common ratio $\frac{4}{3}$. Find the greatest number of terms the series can have without its sum exceeding 100.

Solution:

$$a = 4, \quad r = \frac{4}{3}$$

$$S_n =$$

$$\frac{4 \left(\left(\frac{4}{3} \right)^n - 1 \right)}{\frac{4}{3} - 1}$$

$$\text{Use } S_n = \frac{a(r^n - 1)}{r - 1}. \text{ Here } a = 4 \text{ and } r = \frac{4}{3}.$$

$$= \frac{4 \left(\left(\frac{4}{3} \right)^n - 1 \right)}{\frac{1}{3}}$$

$$= 12 \left(\left(\frac{4}{3} \right)^n - 1 \right)$$

$$n - 1$$

$$\text{Now, } 12 \left(\left(\frac{4}{3} \right)^n - 1 \right) < 100$$

$$\left(\frac{4}{3} \right)^n - 1 < \frac{100}{12}$$

$$\left(\frac{4}{3} \right)^n < \frac{100}{12} + 1$$

$$\left(\frac{4}{3} \right)^n < 9 \frac{1}{3}$$

$$\left(\frac{4}{3} \right)^7 = 7.492$$

$$\left(\frac{4}{3} \right)^8 = 9.990$$

Substitute values of n . The largest value of n for which $\left(\frac{4}{3} \right)^n < 9 \frac{1}{3}$ is 7.

$$\text{so } n = 7$$

Solutionbank C2

Edexcel Modular Mathematics for AS and A-Level

Revision Exercises 2

Exercise A, Question 25

Question:

Describe geometrically the transformation which maps the graph of

(a) $y = \tan x$ onto the graph of $y = \tan (x - 45^\circ)$,

(b) $y = \sin x$ onto the graph of $y = 3\sin x$,

(c) $y = \cos x$ onto the graph of $y = \cos \frac{x}{2}$,

(d) $y = \sin x$ onto the graph of $y = \sin x - 3$.

Solution:

- (a) A translation of $+45^\circ$ in the x direction
- (b) A stretch of scale factor 3 in the y direction
- (c) A stretch of scale factor 2 in the x direction
- (d) A translation of -3 in the y direction

Solutionbank C2

Edexcel Modular Mathematics for AS and A-Level

Revision Exercises 2

Exercise A, Question 26

Question:

If x is so small that terms of x^3 and higher can be ignored, and $(2 - x)(1 + 2x)^5 \approx a + bx + cx^2$, find the values of the constants a , b and c .

Solution:

$$(1 + 2x)^5 = 1 + nx + \frac{n(n-1)}{2!}x^2 + \dots$$

$$= 1 + 5(2x) + \frac{5(4)}{2}$$

$$(2x)^2 + \dots$$

$$= 1 + 10x + 40x^2 + \dots$$

$$(2 - x)(1 + 10x + 40x^2 + \dots)$$

$$= 2 + 20x + 80x^2 + \dots$$

$$- x - 10x^2 + \dots$$

$$2 + 19x + 70x^2 + \dots$$

$$(2 - x)(1 + 2x)^5 \approx 2 + 19x + 70x^2$$

$$\text{so } a = 2, \quad b = 19, \quad c = 70$$

Compare $(1 + x)^n$ with $(1 + 2x)^n$. Replace n by 5 and 'x' by $2x$.

Expand $(2 - x)(1 + 10x + 40x^2 + \dots)$ ignoring terms in x^3 , so that

$$2 \times (1 + 10x + 40x^2 + \dots)$$

$$= 2 + 20x + 80x^2 + \dots$$

and

$$- x \times (1 + 10x + 40x^2 + \dots)$$

$$= -x - 10x^2 - 40x^3$$

simplify so that

$$2 + 20x - x + 80x^2 - 10x^2 + \dots$$

$$= 2 + 19x + 70x^2 + \dots$$

Compare $2 + 19x + 70x^2 + \dots$ with $a + bx + cx^2 + \dots$ so that $a = 2$, $b = 19$ and $c = 70$.

Solutionbank C2

Edexcel Modular Mathematics for AS and A-Level

Revision Exercises 2

Exercise A, Question 27

Question:

A chord of a circle, radius 20 cm, divides the circumference in the ratio 1:3.

Find the ratio of the areas of the segments into which the circle is divided by the chord.

Solution:

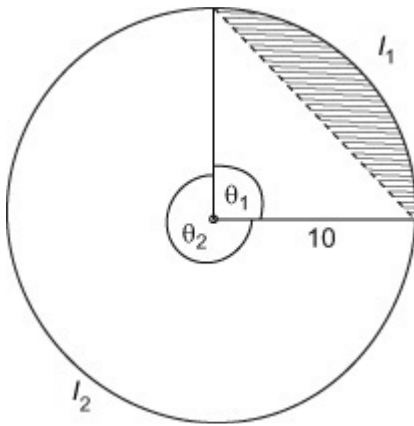

Draw a diagram. Let the minor arc l_1 have angle θ_1 and the major arc l_2 have angle θ_2 .

$$l_1 : l_2 = 1 : 3$$

$$10\theta_1 : 10\theta_2 = 1 : 3$$

$$\theta_1 : \theta_2 = 1 : 3$$

$$\text{so } \theta_1 = \frac{1}{4} \times 2\pi = \frac{\pi}{2}$$

$$\begin{aligned} \text{Shaded area} &= \frac{1}{2} (10)^2 \theta_1 - \frac{1}{2} (10)^2 \sin \theta_1 \\ &= 25\pi - 50 \end{aligned}$$

$$\begin{aligned} \text{Area of large segment} &= \pi (10)^2 - (25\pi - 50) \\ &= 100\pi - 25\pi + 50 \\ &= 75\pi + 50 \end{aligned}$$

Ratio of small segment to large segment is

$$25\pi - 50 : 75\pi + 50$$

$$\pi - 2 : 3\pi + 2$$

$$\text{or } 1 : \frac{3\pi + 2}{\pi - 2}$$

$$\text{Use } l = r\theta \text{ so that } l_1 = 10\theta_1 \text{ and } l_2 = 10\theta_2.$$

$$\begin{aligned} \text{Use area of segment} &= \frac{1}{2} r^2 \theta - \frac{1}{2} r^2 \sin \theta. \text{ Here} \\ r &= 10 \text{ and } \theta = \theta_1 = \frac{\pi}{2} \end{aligned}$$

Divide throughout by 25.

Solutionbank C2

Edexcel Modular Mathematics for AS and A-Level

Revision Exercises 2

Exercise A, Question 28

Question:

x , 3 and $x + 8$ are the fourth, fifth and sixth terms of geometric series.

(a) Find the two possible values of x and the corresponding values of the common ratio.

Given that the sum to infinity of the series exists,

(b) find the first term,

(c) the sum to infinity of the series.

Solution:

$$ar^3 = x$$

$$ar^4 = 3$$

$$ar^5 = x + 8$$

$$\frac{ar^5}{ar^4} = \frac{ar^4}{ar^3}$$

$$\text{so } \frac{x+8}{3} = \frac{3}{x}$$

$$x(x+8) = 9$$

$$x^2 + 8x - 9 = 0$$

$$(x+9)(x-1) = 0$$

$$x = 1, x = -9$$

$$r = \frac{ar^4}{ar^3} = \frac{x}{3}$$

$$\text{When } x = 1, r = \frac{1}{3}$$

$$\text{When } x = -9, r = -3$$

(b)

$$r = \frac{1}{3}$$

$$ar^4 = 3$$

$$a \left(\frac{1}{3} \right)^4 = 3$$

$$a = 243$$

(c)

$$\frac{ar^5}{ar^4} = r \text{ and } \frac{ar^4}{ar^3} = r \text{ so } \frac{ar^5}{ar^4} = \frac{ar^4}{ar^3}$$

Clear the fractions. Multiply each side by $3x$ so that $3x \times$

$$\frac{x+8}{3} = x(x+8) \text{ and } 3x \times \frac{3}{x} = 9.$$

Find r . Substitute $x = 1$, then $x = -9$, into $\frac{ar^4}{ar^3} = \frac{x}{3}$, so that

$$r = \frac{1}{3} \text{ and } r = \frac{-9}{3} = -3.$$

Remember $S_{\infty} = \frac{a}{1-r}$ for $|r| < 1$, so $r = \frac{1}{3}$.

$$\frac{a}{1-r} = \frac{243}{1-\frac{1}{3}} = 364\frac{1}{2}$$

© Pearson Education Ltd 2008

Solutionbank C2

Edexcel Modular Mathematics for AS and A-Level

Revision Exercises 2

Exercise A, Question 29

Question:

- (a) Sketch the graph of $y = 1.5 \cos (x - 60^\circ)$ in the interval $0 \leq x < 360^\circ$
- (b) Write down the coordinates of the points where your graph meets the coordinate axes.

Solution:

(a)

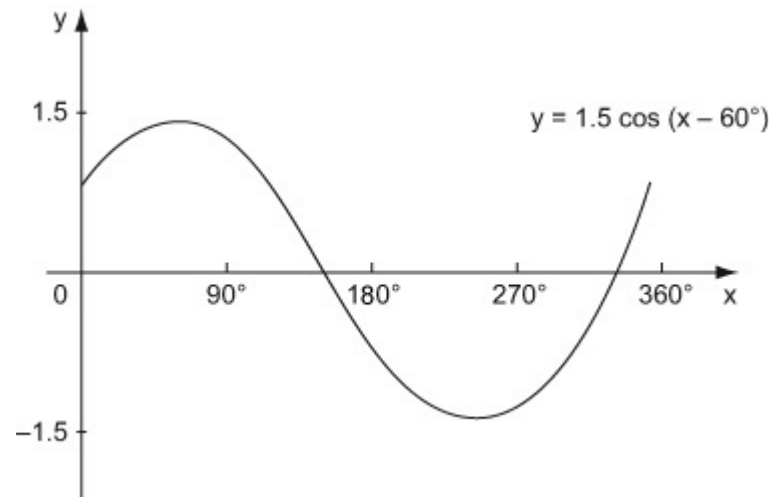

(b)

When $x = 0$,

$$y = 1.5 \cos (-60^\circ)$$

$$= 0.75$$

so $(0, 0.75)$

$$y = 1.5 \cos (x - 60^\circ)$$

$y = 0$,

when $x = 90^\circ + 60^\circ$

$$= 150^\circ$$

and $x = 270^\circ + 60^\circ$

$$= 330^\circ$$

The graph of $y = 1.5 \cos (x - 60^\circ)$ meets the y axis when $x = 0$. Substitute $x = 0$ into $y = 1.5 \cos (x - 60^\circ)$ so that $y = 1.5 \cos (-60^\circ) = \cos (-60^\circ)$
 $= \cos 60^\circ = \frac{1}{2}$ so $y = 1.5 \times \frac{1}{2} = 0.75$

The graph of $y = 1.5 \cos (x - 60^\circ)$ meets the x -axis when $y = 0$. $\cos (x - 60^\circ)$ represents a translation of $\cos x$ by $+60^\circ$ in the x -direction $\cos x$ meets the x -axis at 90° and 270° , so $y = 1.5 (\cos x - 60^\circ)$ meets the x -axis at $90^\circ + 60^\circ = 150^\circ$ and $270^\circ + 60^\circ = 330^\circ$.

Solutionbank C2

Edexcel Modular Mathematics for AS and A-Level

Revision Exercises 2

Exercise A, Question 30

Question:

Without using a calculator, solve $\sin (x - 20^\circ) = -\frac{\sqrt{3}}{2}$ in the interval $0 \leq x \leq 360^\circ$.

Solution:

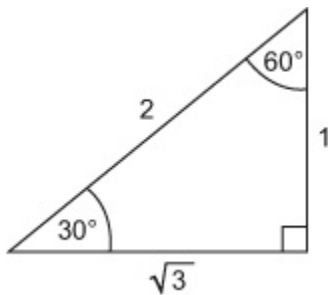

$$\sin 60^\circ = \frac{\sqrt{3}}{2}$$

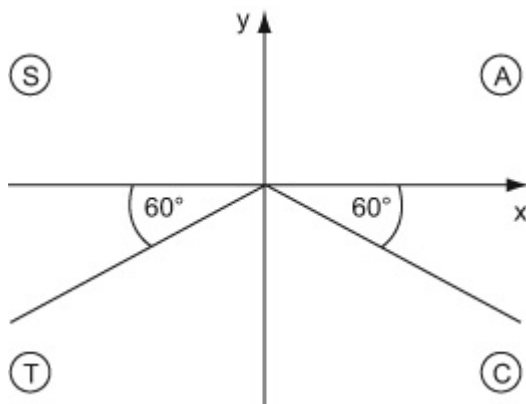

$$\sin (240^\circ) = -\frac{\sqrt{3}}{2}$$

$$\sin (300^\circ) = -\frac{\sqrt{3}}{2}$$

$$\text{so } x - 20^\circ = 240^\circ$$

$$x = 260^\circ$$

$$\text{and } x - 20^\circ = 300^\circ$$

$$x = 320^\circ$$

$\sin x = -\frac{\sqrt{3}}{2}$. $\sin x$ is negative in the 3rd and 4th quadrants.

$$\sin 240^\circ = -\frac{\sqrt{3}}{2} \text{ but } \sin (x - 20^\circ) = -\frac{\sqrt{3}}{2} \text{ so}$$

$$x - 20^\circ = 240^\circ, \text{ i.e. } x = 260^\circ. \text{ Similarly}$$

$$\sin 300^\circ = -\frac{\sqrt{3}}{2} \text{ but } \sin (x - 20^\circ) = -\frac{\sqrt{3}}{2} \text{ so}$$

$$x - 20^\circ = 300^\circ, \text{ i.e. } x = 320^\circ.$$

Solutionbank C1

Edexcel Modular Mathematics for AS and A-Level

Algebra and functions

Exercise A, Question 1

Question:

Find the values of x for which $f(x) = x^3 - 3x^2$ is a decreasing function.

Solution:

$$f(x) = x^3 - 3x^2$$

$$f'(x) = 3x^2 - 6x$$

$$3x^2 - 6x < 0$$

$$3x(x - 2) < 0$$

$f(x)$ is a decreasing function for
 $0 < x < 2$.

Find $f'(x)$ and put this expression < 0 .

Solve the inequality by factorisation, consider the three regions $x < 0$, $0 < x < 2$ and $x > 2$, looking for sign changes.

$$\frac{dy}{dx} < 0 \text{ for } 0 < x < 2$$

Solutionbank C1

Edexcel Modular Mathematics for AS and A-Level

Algebra and functions

Exercise A, Question 2

Question:

Given that A is an acute angle and $\cos A = \frac{2}{3}$, find the exact value of $\tan A$.

Solution:

$$\cos A = \frac{2}{3}$$

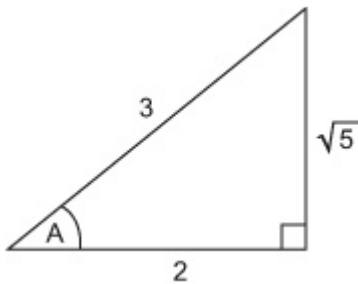

$$\text{so } \tan A = \frac{\sqrt{5}}{2}$$

Draw a diagram and put in the information for $\cos A$.

Use Pythagoras theorem: $a^2 + b^2 = c^2$ with $b = 2$ and $c = 3$.

so

$$a^2 + 2^2 = 3^2$$

$$a^2 + 4 = 9$$

$$a^2 = 5$$

$$a = \sqrt{5}$$

Solutionbank C1

Edexcel Modular Mathematics for AS and A-Level

Algebra and functions

Exercise A, Question 3

Question:

Evaluate $\int_1^3 3x^2 - \frac{1}{x^2} dx$.

Solution:

$$\int_1^3 3x^2 - \frac{1}{x^2} dx$$

$$\begin{aligned} &= \left[\frac{x^3}{3} + \frac{1}{x} \right]_1^3 \\ &= \left(\frac{(3)^3}{3} + \frac{1}{(3)} \right) - \left(\frac{(1)^3}{3} + \frac{1}{(1)} \right) \\ &= \left(9 + \frac{1}{3} \right) - \left(\frac{1}{3} + 1 \right) \\ &= 8 \end{aligned}$$

$$\text{Remember } \int ax^n dx = \frac{ax^{n+1}}{n+1}$$

Change $\frac{-1}{x^2}$ into index form and integrate:

$$\begin{aligned} \frac{-1}{x^2} &= -1x^{-2} \\ \int -1x^{-2} dx &= \frac{-1x^{-2+1}}{-2+1} \\ &= \frac{-1x^{-1}}{-1} \\ &= x^{-1} \\ &= \frac{1}{x} \end{aligned}$$

Evaluate the integral: substitute $x = 3$, then $x = 1$, and subtract.

Solutionbank C1

Edexcel Modular Mathematics for AS and A-Level

Algebra and functions

Exercise A, Question 4

Question:

Given that $y = \frac{x^3}{3} + x^2 - 6x + 3$, find the values of x when $\frac{dy}{dx} = 2$.

Solution:

$$y = \frac{x^3}{3} + x^2 - 6x + 3$$

$$\frac{dy}{dx} = \frac{3x^2}{3} + 2x - 6$$

$$x^2 + 2x - 6 = 2$$

$$x^2 + 2x - 8 = 0$$

$$(x + 4)(x - 2) = 0$$

$$\text{so } x = -4, \quad x = 2$$

$$\text{Remember } \frac{d}{dx} (ax^n) = anx^{n-1}$$

Put $\frac{dy}{dx} = 2$ and solve the equation.

Factorise $x^2 + 2x - 8 = 0$:

$$(+4) \times (-2) = -8$$

$$(+4) + (-2) = +2$$

$$\text{so } x^2 + 2x - 8 = (x + 4)(x - 2)$$

Solutionbank C1

Edexcel Modular Mathematics for AS and A-Level

Algebra and functions

Exercise A, Question 5

Question:

Solve, for $0 \leq x < 180^\circ$, the equation $\cos 2x = -0.6$, giving your answers to 1 decimal place.

Solution:

$$\cos 2x = -0.6$$

$$2x = 126.87^\circ$$

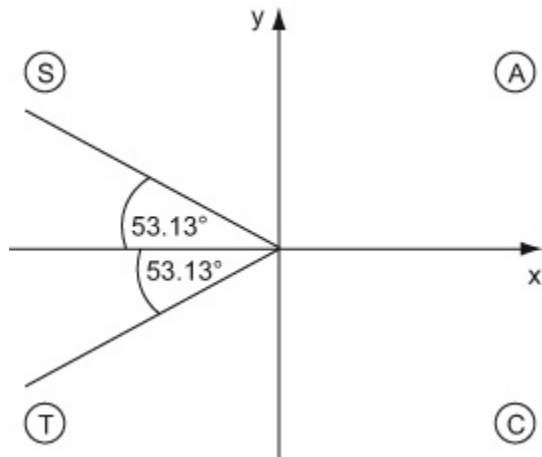

$\cos 2x$ is negative, so you need to look in the 2nd and 3rd quadrants. Here the angle in the 2nd quadrant is $180^\circ - 126.87^\circ = 53.13^\circ$

$$2x = 126.87, 233.13$$

$$\text{so } x = 63.4^\circ, 116.6^\circ$$

Read off the solutions from your diagram

Find x : divide each value by 2.

Solutionbank C1

Edexcel Modular Mathematics for AS and A-Level

Algebra and functions

Exercise A, Question 6

Question:

Find the area between the curve $y = x^3 - 3x^2$, the x -axis and the lines $x = 2$ and $x = 4$.

Solution:

$$\text{Area} = \int_2^4 x^3 - 3x^2 dx$$

$$\text{Remember } \int ax^n dx = \frac{ax^{n+1}}{n+1}$$

$$= \left[\frac{x^4}{4} - x^3 \right]_2^4$$

$$= \left(\frac{(4)^4}{4} - (4)^3 \right) - \left(\frac{(2)^4}{4} - (2)^3 \right)$$

Use the limits: Substitute $x = 4$ and $x = 2$ into $\frac{x^4}{4} - x^3$ and subtract.

$$= (64 - 64) - \left(\frac{16}{4} - 8 \right)$$

$$= 0 - (4 - 8)$$

$$= 0 - (-4)$$

$$= 4$$

Solutionbank C1

Edexcel Modular Mathematics for AS and A-Level

Algebra and functions

Exercise A, Question 7

Question:

Given $f(x) = x^3 - 2x^2 - 4x$,

(a) find (i) $f(2)$, (ii) $f'(2)$, (iii) $f''(2)$

(b) interpret your answer to part (a).

Solution:

$$f(x) = x^3 - 2x^2 - 4x$$

$$f'(x) = 3x^2 - 4x - 4$$

$$f''(x) = 6x - 4$$

$$\text{Remember } f'(x) = \frac{d}{dx}f(x), f''(x) = \frac{d^2}{dx^2}f(x)$$

(a)

(i)

$$\begin{aligned} f(2) &= (2)^3 - 2(2)^2 - 4(2) \\ &= 8 - 8 - 8 \\ &= -8 \end{aligned}$$

Find the value of $f(x)$ where $x = 2$; substitute $x = 2$ into $x^3 - 2x^2 - 4x$

(ii)

$$\begin{aligned} f'(2) &= 3(2)^2 - 4(2) - 4 \\ &= 12 - 8 - 4 \\ &= 0 \end{aligned}$$

Find the value of $f'(x)$ where $x = 2$; substitute $x = 2$ into $3x^2 - 4x - 4$

(iii)

$$\begin{aligned} f''(2) &= 6(2) - 4 \\ &= 12 - 4 \\ &= 8 \end{aligned}$$

Find the value of $f''(x)$ when $x = 2$; Substitute $x = 2$ into $6x - 4$.

(b)

On the graph of $y = f(x)$, the point $(2, -8)$ is a minimum point.

$f'(2) = 0$ means there is a stationary point at $x = 2$

$f''(2) = 8 > 0$ means the stationary point is a minimum.

$f(2) = -8$ means the graph of $y = f(u)$ passes through the point $(2, -8)$.

Solutionbank C1

Edexcel Modular Mathematics for AS and A-Level

Algebra and functions

Exercise A, Question 8

Question:

Find all the values of θ in the interval $0 \leq \theta < 360^\circ$ for which $2\sin(\theta - 30^\circ) = \sqrt{3}$.

Solution:

$$2\sin(\theta - 30^\circ) = \sqrt{3}$$

$$\sin(\theta - 30^\circ) = \frac{\sqrt{3}}{2}$$

$$\theta - 30^\circ = 60^\circ$$

Divide each side by 2.

Solve the equation: let $X = \theta - 30^\circ$ $\sin X = \frac{\sqrt{3}}{2}$, so

$X = 60^\circ$ i.e. $\theta - 30^\circ = 60^\circ$

$\sin(\theta - 30^\circ)$ is positive so you need to look in the 1st and 2nd quadrants.

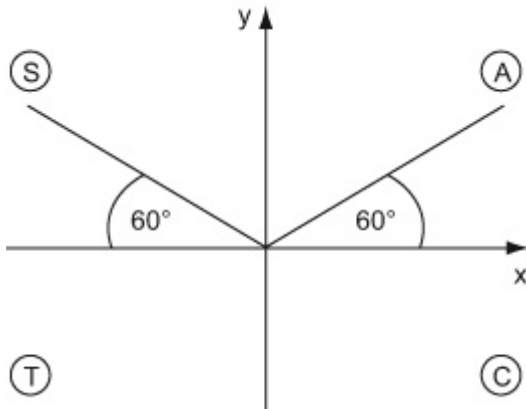

$$\theta - 30^\circ = 60^\circ, 120^\circ$$

$$\text{so } \theta = 60 + 30^\circ$$

$$= 90^\circ$$

$$\text{and } \theta = 120 + 30^\circ$$

$$= 150^\circ$$

$$\theta = 90^\circ, 150^\circ$$

Read off the solutions from your diagram

Find θ : add 30° to each value.

Solutionbank C1

Edexcel Modular Mathematics for AS and A-Level

Algebra and functions

Exercise A, Question 9

Question:

The diagram shows the shaded region T which is bounded by the curve $y = (x - 1)(x - 4)$ and the x -axis. Find the area of the shaded region T .

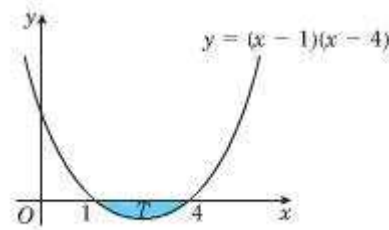

Solution:

$$\text{Area} = \int_1^4 (x - 1)(x - 4) \, dx$$

$$= \int_1^4 x^2 - 5x + 4 \, dx$$

$$= \left[\frac{x^3}{3} - \frac{5x^2}{2} + 4x \right]_1^4$$

$$= \left(\frac{(4)^3}{3} - \frac{5(4)^2}{2} + 4(4) \right) - \left(\frac{(1)^3}{3} - \frac{5(1)^2}{2} + 4(1) \right)$$

$$= -4 \frac{1}{2}$$

$$\text{Area} = 4 \frac{1}{2}$$

Expand the brackets so that

$$\begin{aligned} (x - 1)(x - 4) &= x^2 - 4x - x + 4 \\ &= x^2 - 5x + 4 \end{aligned}$$

Remember $\int ax^n dx = \frac{ax^{n+1}}{n+1}$

Evaluate the integral. Substitute $x = 4$, then $x = 1$, into $\frac{x^3}{3} - \frac{5x^2}{2} + 4x$ and subtract.

The negative value means the area is below the x -axis, as can be seen in the diagram.

Solutionbank C1

Edexcel Modular Mathematics for AS and A-Level

Algebra and functions

Exercise A, Question 10

Question:

Find the coordinates of the stationary points on the curve with equation $y = 4x^3 - 3x + 1$.

Solution:

$$y = 4x^3 - 3x + 1$$

$$\frac{dy}{dx} = 12x^2 - 3$$

$$12x^2 - 3 = 0$$

$$12x^2 = 3$$

$$x^2 = \frac{3}{12}$$

$$= \frac{1}{4}$$

$$x = \sqrt{\frac{1}{4}}$$

$$= \pm \frac{1}{2}$$

Remember $\frac{dy}{dx} = 0$ at a stationary point.

When $x = \frac{1}{2}$,

$$y = 4 \left(\frac{1}{2} \right)^3 - 3 \left(\frac{1}{2} \right) + 1$$

$$= 4 \left(\frac{1}{8} \right) - \frac{3}{2} + 1$$

$$= 0$$

Find the coordinates of the stationary points. Substitute $x = \frac{1}{2}$ and $x = -\frac{1}{2}$ into the equation for y .

When $x = -\frac{1}{2}$

$$y = 4 \left(-\frac{1}{2} \right)^3 - 3 \left(-\frac{1}{2} \right) + 1$$

$$= 4 \left(-\frac{1}{8} \right) + \frac{3}{2} + 1$$

$$= -\frac{1}{2} + \frac{3}{2} + 1$$

$$= 2$$

Find the coordinates of the stationary points. Substitute $x = \frac{1}{2}$ and $x = -\frac{1}{2}$ into the equation for y .

So the coordinates of the stationary points

are $\left(\frac{1}{2}, 0 \right)$ and $\left(-\frac{1}{2}, 2 \right)$.

Solutionbank C1

Edexcel Modular Mathematics for AS and A-Level

Algebra and functions

Exercise A, Question 11

Question:

- (a) Given that $\sin \theta = \cos \theta$, find the value of $\tan \theta$.
- (b) Find the value of θ in the interval $0 \leq \theta < 2\pi$ for which $\sin \theta = \cos \theta$, giving your answer in terms of π .

Solution:

(a)

$$\sin \theta = \cos \theta$$

$$\frac{\sin \theta}{\cos \theta} = \frac{\cos \theta}{\cos \theta}$$

$$\tan \theta = 1$$

Remember $\tan \theta = \frac{\sin \theta}{\cos \theta}$

Divide each side by $\cos \theta$.

(b)

$$\theta = \frac{\pi}{4}$$

$\tan \theta = 1$, so $\theta = 45^\circ$. Remember π (radians)

$$= 180^\circ \text{ so } 45^\circ = \frac{\pi}{4} \text{ (radians).}$$

$\tan \theta$ is positive in the 1st and 3rd quadrants. Read off the solutions, in $0 \leq \theta < 2\pi$, from your diagram.

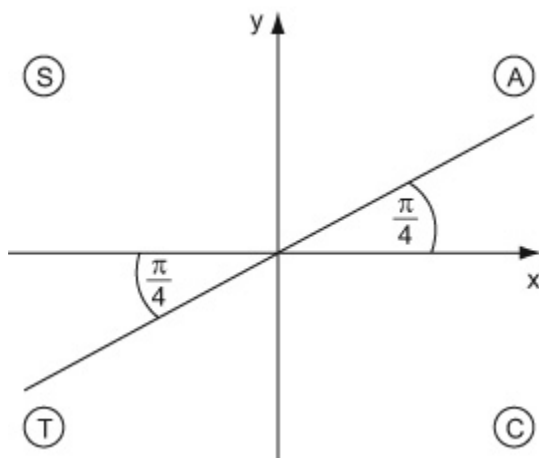

$$\theta = \frac{\pi}{4}, \frac{5\pi}{4}$$

$$\pi + \frac{\pi}{4} = \frac{5\pi}{4}$$

Solutionbank C1

Edexcel Modular Mathematics for AS and A-Level

Algebra and functions

Exercise A, Question 12

Question:

(a) Sketch the graph of $y = \frac{1}{x}$, $x > 0$.

(b) Copy and complete the table, giving your values of $\frac{1}{x}$ to 3 decimal places.

x	1	1.2	1.4	1.6	1.8	2
$\frac{1}{x}$	1					0.5

(c) Use the trapezium rule, with all the values from your table, to find an estimate for the value of $\int_1^2 \frac{1}{x} dx$.

(d) Is this an overestimate or an underestimate for the value of $\int_1^2 \frac{1}{x} dx$? Give a reason for your answer.

Solution:

(a)

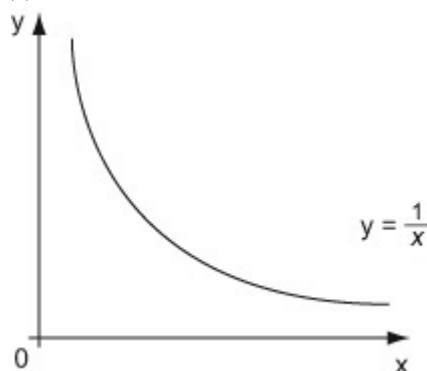

Draw the sketch for $x > 0$.

(b)

x	1	1.2	1.4	1.6	1.8	2
$\frac{1}{x}$	1	0.833	0.714	0.625	0.556	0.5

(c)

$$\begin{aligned} \text{Area} &\approx \frac{1}{2} \times 0.2 \times [1 + 2(0.833 + 0.714 + 0.625 + 0.556) \\ &\quad + 0.5] \\ &\approx 0.6956 \\ &\approx 0.70. \end{aligned}$$

The width of each strip is 0.2

The values of $\frac{1}{x}$ are to 3 decimal places, so give the final answer to 2

decimal places.

(d)

This is an overestimate.

Due to the shape of the curve, each trapezium will give an area slightly larger than the area under the graph.

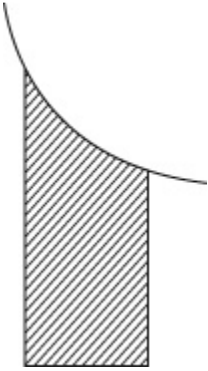

© Pearson Education Ltd 2008

Solutionbank C1

Edexcel Modular Mathematics for AS and A-Level

Algebra and functions

Exercise A, Question 13

Question:

Show that the stationary point on the curve $y = 4x^3 - 6x^2 + 3x + 2$ is a point of inflexion.

Solution:

$$y = 4x^3 - 6x^2 + 3x + 2$$

$$\frac{dy}{dx} = 12x^2 - 12x + 3$$

$$12x^2 - 12x + 3 = 0$$

$$4x^2 - 4x + 1 = 0$$

$$(2x - 1)(2x - 1) = 0$$

$$x = \frac{1}{2}$$

When $x = 0$,

$$\frac{dy}{dx} = 12(0) - 12(0) + 3$$

$$= 3 > 0$$

When $x = 1$

$$\frac{dy}{dx} = 12(1)^2 - 12(1) + 3$$

$$= 3 > 0$$

Find the stationary point. Put $\frac{dy}{dx} = 0$

Simplify. Divide throughout by 4. Factorise

$$4x^2 - 4x + 1$$



$$ac = 4, \text{ and } (-2) + (-2) = -4$$

$$\text{so } 4x^2 - 2x - 2x + 1$$

$$= 2x(2x - 1) - 1(2x - 1)$$

$$= (2x - 1)(2x - 1)$$

Find the gradient of the tangent when $x = 0$ and $x = 1$.

x	0	$\frac{1}{2}$	1
$\frac{dy}{dx}$	>0	0	>0
Shape of curve			

Look at the gradient of the tangent on either side of the stationary point.

The Stationary point is a point of inflexion.

Solutionbank C1

Edexcel Modular Mathematics for AS and A-Level

Algebra and functions

Exercise A, Question 14

Question:

Find all the values of x in the interval $0 \leq x < 360^\circ$ for which $3\tan^2x = 1$.

Solution:

$$3\tan^2x = 1$$

$$\tan^2x = \frac{1}{3}$$

$$\tan x = \pm \sqrt{\frac{1}{3}}$$

(i)

$$\tan x = \pm \frac{1}{\sqrt{3}}$$

$$x = 30^\circ$$

Rearrange the equation for $\tan x$. Divide each side by 3.

Take the square root of each side.

$$\sqrt{\frac{1}{3}} = \frac{\sqrt{1}}{\sqrt{3}} = \frac{1}{\sqrt{3}}$$

Remember

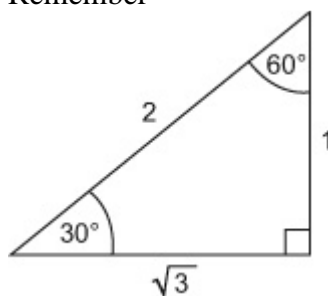

$$\text{so } \tan 30^\circ = \frac{1}{\sqrt{3}}$$

Tan x is positive in the 1st and 3rd quadrants.

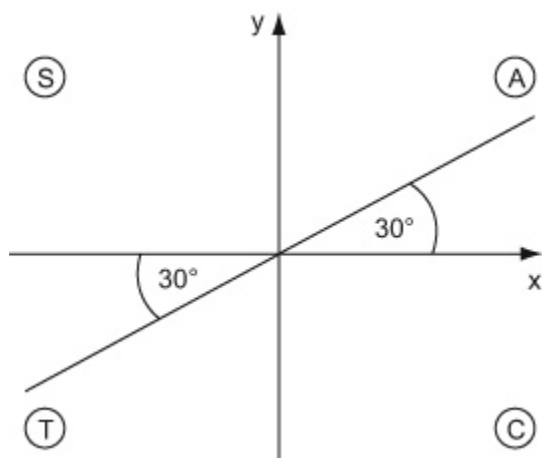

so, $x = 30^\circ, 210^\circ$

(ii)

$$\tan x = -\frac{1}{\sqrt{3}}$$

$$x = 330^\circ \text{ (i.e. } -30^\circ \text{)}$$

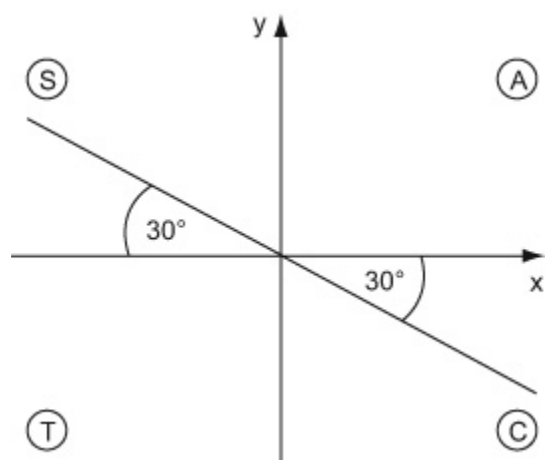

Tan x is negative in the 2nd and 4th quadrants.

$$x = 330^\circ, 150^\circ$$

$$\text{so, } x = 30^\circ, 150^\circ, 210^\circ, 330^\circ$$

Write down all the solutions in $0 \leq x < 360^\circ$ in order of size.

Solutionbank C1

Edexcel Modular Mathematics for AS and A-Level

Algebra and functions

Exercise A, Question 15

Question:

Evaluate $\int_1^8 8x^{\frac{1}{3}} - x^{-\frac{1}{3}} dx$.

Solution:

$$\int_1^8 8x^{\frac{1}{3}} - x^{-\frac{1}{3}} dx$$

$$= \left[\frac{3}{4}x^{\frac{4}{3}} - \frac{3}{2}x^{\frac{2}{3}} \right]_1^8$$

$$\begin{aligned} &= \left(\frac{3}{4}(8)^{\frac{4}{3}} - \frac{3}{2}(8)^{\frac{2}{3}} \right) - \left(\frac{3}{4}(1)^{\frac{4}{3}} - \frac{3}{2}(1)^{\frac{2}{3}} \right) \\ &= \left(\frac{3}{4}(16) - \frac{3}{2}(4) \right) - \left(\frac{3}{4} - \frac{3}{2} \right) \\ &= (12 - 6) - \left(\frac{3}{4} - \frac{3}{2} \right) \\ &= 6 \frac{3}{4} \end{aligned}$$

$$\text{Remember } \int ax^n dx = \frac{ax^{n+1}}{n+1}$$

$$\int x^{\frac{1}{3}} dx = \frac{x^{\frac{4}{3}}}{\left(\frac{4}{3}\right)} = \frac{3}{4}x^{\frac{4}{3}}$$

$$\int x^{-\frac{1}{3}} dx = \frac{x^{\frac{2}{3}}}{\left(\frac{2}{3}\right)} = \frac{3}{2}x^{\frac{2}{3}}$$

$$\begin{aligned} &= (8^{\frac{1}{3}})^4 \\ &= (\sqrt[3]{8})^4 \\ &= 2^4 \\ &= 16 \end{aligned}$$

Solutionbank C1

Edexcel Modular Mathematics for AS and A-Level

Algebra and functions

Exercise A, Question 16

Question:

The curve C has equation $y = 2x^3 - 13x^2 + 8x + 1$.

- (a) Find the coordinates of the turning points of C .
 (b) Determine the nature of the turning points of C .

Solution:

$$y = 2x^3 - 13x^2 + 8x + 1$$

Find the x -coordinate. Solve $\frac{dy}{dx} = 0$.

(a)

$$\frac{dy}{dx} = 6x^2 - 26x + 8$$

$$6x^2 - 26x + 8 = 0$$

$$3x^2 - 13x + 4 = 0$$

$$(3x - 1)(x - 4) = 0$$

$$x = \frac{1}{3}, \quad x = 4$$

When $x = \frac{1}{3}$,

$$\begin{aligned} y &= 2\left(\frac{1}{3}\right)^3 - 13\left(\frac{1}{3}\right)^2 + 8\left(\frac{1}{3}\right) + 1 \\ &= 2\frac{8}{27} \end{aligned}$$

When $x = 4$

$$\begin{aligned} y &= 2(4)^3 - 13(4)^2 + 8(4) + 1 \\ &= -47 \end{aligned}$$

so $\left(\frac{1}{3}, 2\frac{8}{27}\right)$, $(4, -47)$.

Divide throughout by 2.

$$\begin{aligned} \text{Factorize } 3x^2 - 13x + 4 = 0. \quad ac = 12, \quad (-12) \\ + (-1) = -13 \\ \text{so } 3x^2 - 12x - x + 4 \\ = 3x(x - 4) - 1(x - 4) \\ = (3x - 1)(x - 4) \end{aligned}$$

Find the y -coordinates. Substitute $x = \frac{1}{3}$ and $x = 4$ into $y = 2x^3 - 13x^2 + 8x + 1$

Give your answer as coordinates

(b)

$$\frac{d^2y}{dx^2} = 12x - 26$$

Remember $\frac{d^2y}{dx^2} < 0$ is a maximum stationary point, and

When $x = \frac{1}{3}$,

$\frac{d^2y}{dx^2} > 0$ is a minimum stationary point.

$$\begin{aligned}\frac{d^2y}{dx^2} &= 12 \left(\frac{1}{3} \right) - 26 \\ &= -22 < 0\end{aligned}$$

$\left(\frac{1}{3}, 2\frac{8}{27} \right)$ is a maximum.

When $x = 4$,

$$\begin{aligned}\frac{d^2y}{dx^2} &= 12(4) - 26 \\ &= 22 > 0\end{aligned}$$

$(4, -47)$ is a minimum.

Solutionbank C1

Edexcel Modular Mathematics for AS and A-Level

Algebra and functions

Exercise A, Question 17

Question:

The curve S , for $0 \leq x < 360^\circ$, has equation $y = 2\sin \left(\frac{2}{3}x - 30^\circ \right)$.

(a) Find the coordinates of the point where S meets the y -axis.

(b) Find the coordinates of the points where S meets the x -axis.

Solution:

$$y = 2\sin \left(\frac{2}{3}x - 30^\circ \right)$$

(a)

$$x = 0$$

$$y = 2\sin \left(\frac{2}{3}(0) - 30^\circ \right)$$

$$= 2\sin \left(-30^\circ \right)$$

$$= -2$$

so, $(0, -2)$

The curve $y = 2\sin \left(\frac{2x}{3} - 30^\circ \right)$ meets the y -axis

when $x = 0$, so substitute $x = 0$ into $y = 2\sin \left(\frac{2x}{3} - 30^\circ \right)$.

(b)

$$y = 0$$

$$2\sin \left(\frac{2}{3}x - 30^\circ \right) = 0$$

$$\sin \left(\frac{2}{3}x - 30^\circ \right) = 0$$

$$\frac{2}{3}x - 30^\circ = 0^\circ, 180^\circ, 360^\circ,$$

The curve $y = 2\sin \left(\frac{2x}{3} - 30^\circ \right)$ meets the x -axis

when $y = 0$, so substitute $y = 0$ into $y = 2\sin \left(\frac{2x}{3} - 30^\circ \right)$.

(i)

$$\frac{2}{3}x - 30^\circ = 0$$

$$\frac{2}{3}x = 30^\circ$$

$$x = 45^\circ$$

Let $\frac{2}{3}x - 30^\circ = X$ so $\sin X = 0$ Now,

$X = 0, 180^\circ, 360^\circ$ Solve for x : $X = 0$, so

$$\frac{2x}{3} - 30^\circ = 0.$$

(ii)

$X = 180^\circ$, so $\frac{2x}{3} - 30^\circ = 180^\circ$.

$$\frac{2}{3}x - 30^\circ = 180^\circ$$

$$\frac{2}{3}x = 210^\circ$$

$$x = 315^\circ$$

(iii)

$$\frac{2}{3}x - 30^\circ = 360^\circ$$

$$\frac{2}{3}x = 390^\circ$$

$$x = 585^\circ$$

so $(45^\circ, 0)$, $(315^\circ, 0)$

$$X = 360^\circ, \text{ so } \frac{2x}{3} - 30^\circ = 360^\circ.$$

Solution not in $0 \leq x < 360^\circ$.

Solutionbank C1

Edexcel Modular Mathematics for AS and A-Level

Algebra and functions

Exercise A, Question 18

Question:

Find the area of the finite region bounded by the curve $y = (1 + x)(4 - x)$ and the x -axis.

Solution:

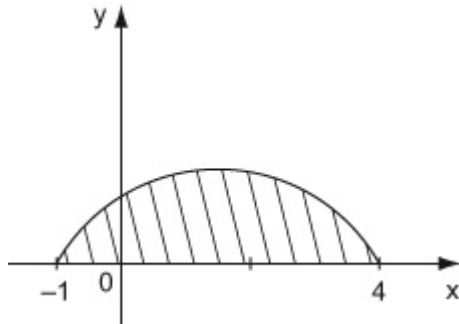

$$\text{Area} = \int_{-1}^4 (1 + x)(4 - x) \, dx$$

$$= \int_{-1}^4 4 + 3x - x^2 \, dx$$

$$= \left[4x + \frac{3x^2}{2} - \frac{x^3}{3} \right]_{-1}^4$$

$$= \left(4(4) + \frac{3}{2}(4)^2 - \frac{(4)^3}{3} \right) - \left(4(-1) + \frac{3}{2}(-1)^2 - \frac{(-1)^3}{3} \right)$$

$$= 18 \frac{2}{3} - \left(-2 \frac{1}{6} \right)$$

$$= 20 \frac{5}{6}$$

Sketch a graph of the curve $y = (1 + x)(4 - x)$.

Find where the curve meets the x -axis.

The curve meets the x -axis when $y = 0$, so substitute $y = 0$ into $y = (1 + x)(4 - x)$

$(1 + x)(4 - x) = 0$ so $x = -1$ and $x = 4$.

Find the area under the graph and the x -axis. Integrate $y = (1 + x)(4 - x)$ using $x = -1$ and $x = 4$ as the limits of the integration.

Expand $(1 + x)(4 - x)$.

$$\begin{aligned} (1 + x)(4 - x) &= 4 - x + 4x - x^2 \\ &= 4 + 3x - x^2 \end{aligned}$$

Remember $\int ax^n dx = \frac{ax^{n+1}}{n+1}$

Evaluate the integral. Substitute $x = 4$,

then $x = -1$ into $4x + \frac{3x^2}{2} - \frac{x^3}{3}$ and subtract.

$$\begin{aligned} 18 \frac{2}{3} - \left(-2 \frac{1}{6} \right) &= 18 \frac{2}{3} + 2 \frac{1}{6} \\ &= 20 \frac{5}{6} \end{aligned}$$

Solutionbank C1

Edexcel Modular Mathematics for AS and A-Level

Algebra and functions

Exercise A, Question 19

Question:

The diagram shows part of the curve with equation $y = 2x^{\frac{1}{2}}(3 - x)$. The curve meets the x -axis at the points O and A . The point B is the maximum point of the curve.

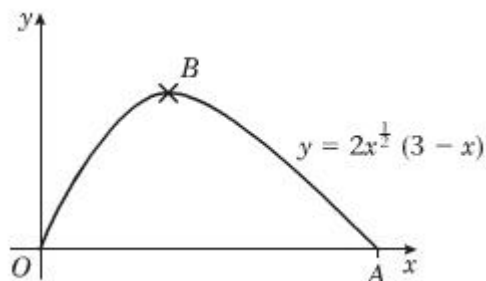

(a) Find the coordinates of A .

(b) Show that $\frac{dy}{dx} = 3x^{-\frac{1}{2}}(1 - x)$.

(c) Find the coordinates of B .

Solution:

$$y = 2x^{\frac{1}{2}}(3 - x)$$

(a)

$$2x^{\frac{1}{2}}(3 - x) = 0$$

(i)

$$x^{\frac{1}{2}} = 0$$

$$x = 0$$

(ii)

$$3 - x = 0$$

$$x = 3$$

so $A(3, 0)$.

The curve meets the x -axis when $y = 0$, so substitute $y = 0$ into $y = 2x^{\frac{1}{2}}(3 - x)$.

Remember $\frac{d}{dx}(ax^n) = anx^{n-1}$

(b)

$$y = 2x^{\frac{1}{2}}(3 - x)$$

$$= 6x^{\frac{1}{2}} - 2x^{\frac{3}{2}}$$

Expand the brackets.

$$\frac{dy}{dx} = 3x^{-\frac{1}{2}} - 3x^{\frac{1}{2}}$$

$$= 3x^{-\frac{1}{2}} (1 - x) \text{ as required}$$

$$2x^{\frac{1}{2}} \times 3 = 6x^{\frac{1}{2}}$$

$$\begin{aligned} 2x^{\frac{1}{2}} \times x &= 2x^{\frac{1}{2}} \times x^1 \\ &= 2x^{\frac{1}{2} + 1} \\ &= 2x^{\frac{3}{2}} \end{aligned}$$

Differentiate.

$$\begin{aligned} \frac{d}{dx} \left(6x^{\frac{1}{2}} \right) &= 6 \times \frac{1}{2} \times x^{\frac{1}{2} - 1} \\ &= 3x^{-\frac{1}{2}} \end{aligned}$$

$$\begin{aligned} \frac{d}{dx} \left(2x^{\frac{3}{2}} \right) &= 2 \times \frac{3}{2} \times x^{\frac{3}{2} - 1} \\ &= 3x^{\frac{1}{2}} \end{aligned}$$

Factorise. Divide each term by $3x^{-\frac{1}{2}}$ so that

$$3x^{-\frac{1}{2}} \div 3x^{-\frac{1}{2}} = 1$$

$$\begin{aligned} 3x^{\frac{1}{2}} \div 3x^{-\frac{1}{2}} &= \frac{3x^{\frac{1}{2}}}{3x^{-\frac{1}{2}}} \\ &= x^{\frac{1}{2} - \left(-\frac{1}{2}\right)} \\ &= x^{\frac{1}{2} + \frac{1}{2}} \\ &= x^1 = x \end{aligned}$$

(c)

$$3x^{-\frac{1}{2}} (1 - x) = 0$$

$$1 - x = 0$$

$$x = 1$$

When $x = 1$,

$$\begin{aligned} y &= 2(1)^{\frac{1}{2}} (3 - (1)) \\ &= 2 \times 1 \times 2 \\ &= 4 \end{aligned}$$

so $B(1, 4)$.

Solutionbank C1

Edexcel Modular Mathematics for AS and A-Level

Algebra and functions

Exercise A, Question 20

Question:

(a) Show that the equation $2\cos^2 x = 4 - 5\sin x$ may be written as $2\sin^2 x - 5\sin x + 2 = 0$.

(b) Hence solve, for $0 \leq \theta < 360^\circ$, the equation $2\cos^2 x = 4 - 5\sin x$.

Solution:

(a)

$$2 \cos^2 x = 4 - 5\sin x$$

$$2(1 - \sin^2 x) = 4 - 5\sin x$$

$$2 - 2\sin^2 x = 4 - 5\sin x$$

$$2\sin^2 x - 5\sin x + 2 = 0 \text{ (as required)}$$

Remember $\cos^2 x + \sin^2 x = 1$ so
 $\cos^2 x = 1 - \sin^2 x$.

(b)

Let $\sin x = y$

$$2y^2 - 5y + 2 = 0$$

$$(2y - 1)(y - 2) = 0$$

Factorise $2y^2 - 5y + 2 = 0$

$$ac = 4, (-1) + (-4) = -5$$

$$\text{so } 2y^2 - 5y + 2 = 2y^2 - y - 4y + 2$$

$$= y(2y - 1) - 2(2y - 1)$$

$$= (2y - 1)(y - 2)$$

$$\text{so } y = \frac{1}{2}, y = 2$$

(i)

$$\sin x = \frac{1}{2}$$

$$x = 30^\circ, 150^\circ$$

Solve for x .

Substitute (i) $y = \frac{1}{2}$ and (ii) $y = 2$ into $\sin x = y$.

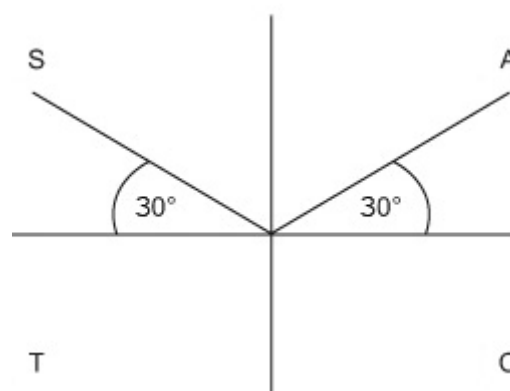

$\sin x$ is positive in the 1st and 2nd quadrants. Read off the solutions in $0 \leq x < 360^\circ$.

(ii)

$\sin x = 2$ (Impossible)

No solutions exist as $-1 \leq \sin x \leq 1$.

so $x = 30^\circ, 150^\circ$

© Pearson Education Ltd 2008

Solutionbank C1

Edexcel Modular Mathematics for AS and A-Level

Algebra and functions

Exercise A, Question 21

Question:

Use the trapezium rule with 5 equal strips to find an estimate for $\int_0^1 x\sqrt{1+x} \, dx$.

Solution:

x	0	0.2	0.4	0.6	0.8	1
$x\sqrt{1+x}$	0	0.219	0.473	0.759	1.073	1.414

Divide the interval into 5 equal strips.

Use $h = \frac{b-a}{n}$. Here $b = 1$, $a = 0$ and

$n = 5$. So that $h = \frac{1-0}{5} = 0.2$

The trapezium rule gives an approximation to the area of the graph. Here we work to an accuracy of 3 decimal places.

Remember $A \approx \frac{1}{2}h [y_0 + 2 (y_1 + y_2 + \dots) + y_n]$

$$\begin{aligned} \int_0^1 x\sqrt{1+x} \, dx &\approx \frac{1}{2} \times 0.2 \times [0 + 2 (0.219 \\ &\quad + 0.473 + 0.759 + 1.073) \\ &\quad + 1.414] \\ &\approx 0.6462 \text{ or } 0.65 \end{aligned}$$

The values of $x\sqrt{1+x}$ are to 3 decimal places, so give your final answer to 2 decimal places.

Solutionbank C1

Edexcel Modular Mathematics for AS and A-Level

Algebra and functions

Exercise A, Question 22

Question:

A sector of a circle, radius r cm, has a perimeter of 20 cm.

(a) Show that the area of the sector is given by $A = 10r - r^2$.

(b) Find the maximum value for the area of the sector.

Solution:

(a)

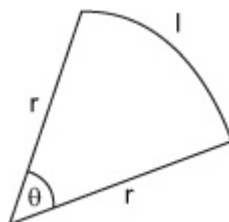

$$2r + l = 20$$

$$l = r\theta$$

$$\text{so } 2r + r\theta = 20$$

$$r\theta = 20 - 2r$$

$$\theta = \frac{20}{r} - 2$$

$$\text{Area} = \frac{1}{2}r^2\theta$$

$$= \frac{1}{2}r^2 \left(\frac{20}{r} - 2 \right)$$

$$= \frac{1}{2}r^2 \times \frac{20}{r} - \frac{1}{2}r^2 \times 2$$

$$= 10r - r^2 \text{ (as required)}$$

Remember: The length of an arc of a circle is $l = r\theta$. The area of a sector of a circle is $A = \frac{1}{2}r^2\theta$.

Draw a diagram. Let θ be the center angle and l be the arc length.

The perimeter of the sector is $r + r + l = 2r + l$ so $2r + l = 20$

Expand the brackets and simplify.

$$\frac{1}{2}r^2 \times \frac{20}{r} = \frac{1}{2} \times 20 \times \frac{r^2}{r}$$

$$= 10r^2 - 1$$

$$= 10r^1 = 10r$$

$$\frac{1}{2}r^2 \times 2 = 2 \times \frac{1}{2}r^2$$

$$= r^2$$

(b)

Find the value of r for the area to have a maximum. Solve

$$\frac{dA}{dr} = 0.$$

$$\frac{dA}{dr} = 10 - 2r$$

$$10 - 2r = 0$$

$$2r = 10$$

$$r = 5$$

when $r = 5$

$$\begin{aligned} \text{Area} &= 10(5) - 5^2 \\ &= 50 - 25 \\ &= 25 \text{ cm}^2 \end{aligned}$$

Find the maximum area. Substitute $r = 5$ into $A = 10r - r^2$

Solutionbank C1

Edexcel Modular Mathematics for AS and A-Level

Algebra and functions

Exercise A, Question 23

Question:

Show that, for all values of x :

(a) $\cos^2 x (\tan^2 x + 1) = 1$

(b) $\sin^4 x - \cos^4 x = (\sin x - \cos x) (\sin x + \cos x)$

Solution:

(a)

$$\begin{aligned} & \cos^2 x (\tan^2 x + 1) \\ &= \cos^2 x \left(\frac{\sin^2 x}{\cos^2 x} + 1 \right) \\ &= \cos^2 x \times \frac{\sin^2 x}{\cos^2 x} + \cos^2 x \times 1 \\ &= \sin^2 x + \cos^2 x \\ &= 1 \text{ (as required)} \end{aligned}$$

Remember $\tan x = \frac{\sin x}{\cos x}$ so $\tan^2 x = \frac{\sin x}{\cos x} \times \frac{\sin x}{\cos x} = \frac{\sin^2 x}{\cos^2 x}$

Expand the brackets and simplify.

$$\begin{aligned} \cos^2 x \times \left(\frac{\sin^2 x}{\cos^2 x} + 1 \right) &= \frac{\sin^2 x}{\cos^2 x} \times \cos^2 x + \cos^2 x \times 1 \\ &= \sin^2 x + \cos^2 x \end{aligned}$$

Remember $\sin^2 x + \cos^2 x = 1$

(b)

$$\begin{aligned} & \sin^4 x - \cos^4 x \\ &= (\sin^2 x - \cos^2 x) (\sin^2 x + \cos^2 x) \\ &= (\sin^2 x - \cos^2 x) \times 1 \\ &= \sin^2 x - \cos^2 x \\ &= (\sin x - \cos x) (\sin x + \cos x) \end{aligned}$$

(as required)

Remember $a^2 - b^2 = (a - b)(a + b)$. Here $a = \sin^2 x$ and $b = \cos^2 x$

Remember $\sin^2 x + \cos^2 x = 1$

Use $a^2 - b^2 = (a - b)(a + b)$ again. Here $a = \sin x$ and $b = \cos x$.

Solutionbank C1

Edexcel Modular Mathematics for AS and A-Level

Algebra and functions

Exercise A, Question 24

Question:

The diagram shows the shaded region R which is bounded by the curves $y = 4x(4 - x)$ and $y = 5(x - 2)^2$.

The curves intersect at the points A and B .

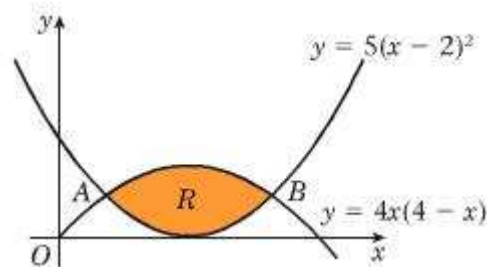

(a) Find the coordinates of the points A and B .

(b) Find the area of the shaded region R .

Solution:

$$y = 4x(4 - x), \quad y = 5(x - 2)^2$$

$$4x(4 - x) = 5(x - 2)^2$$

$$16x - 4x^2 = 5(x^2 - 4x + 4)$$

$$16x - 4x^2 = 5x^2 - 20x + 20$$

$$9x^2 - 36x + 20 = 0$$

$$(3x - 10)(3x - 2) = 0$$

$$x = \frac{10}{3}, \quad x = \frac{2}{3}$$

(i)

When $x = \frac{10}{3}$,

$$y = 4\left(\frac{10}{3}\right)\left(4 - \frac{10}{3}\right)$$

$$= 4 \times \frac{10}{3} \times \frac{2}{3}$$

$$= \frac{80}{3}$$

(ii)

When $x = \frac{2}{3}$

Solve the equations $y = 4x(4 - x)$ and $y = 5(x - 2)^2$ simultaneously. Eliminate y so that $4x(4 - x) = 5(x - 2)^2$.

Expand the brackets and simplify.

Rearrange the equation into the form

$$ax^2 + bx + c = 0$$

Factorise $9x^2 - 36x + 20 = 0$

$$ac = 180, \quad (-6) + (-30) = -36$$

$$9x^2 - 6x - 30x + 20$$

$$= 3x(3x - 2) - 10(3x - 2)$$

$$= (3x - 2)(3x - 10).$$

Find the coordinator of A and B . Substitute (i) $x =$

$$\frac{10}{3} \text{ and (ii) } x = \frac{2}{3}, \text{ into } y = 4x(4 - x).$$

Find the coordinator of A and B . Substitute (i) $x =$

$$\begin{aligned}
 y &= 4 \left(\frac{2}{3} \right) \left(4 - \frac{2}{3} \right) \\
 &= 4 \times \frac{2}{3} \times \frac{10}{3} \\
 &= \frac{80}{3}
 \end{aligned}$$

$\frac{10}{3}$ and (ii) $x = \frac{2}{3}$, into $y = 4x(4 - x)$.

so $A \left(\frac{2}{3}, \frac{80}{3} \right)$, $B \left(\frac{10}{3}, \frac{80}{3} \right)$

(b)

$$\begin{aligned}
 \text{Area} &= \int_{\frac{2}{3}}^{\frac{10}{3}} 4x(4 - x) - 5(x - 2)^2 dx \\
 &= \int_{\frac{2}{3}}^{\frac{10}{3}} 16x - 4x^2 - 5(x^2 - 4x + 4) dx
 \end{aligned}$$

Remember Area = $\int_a^b (y_1 - y_2) dx$. Here

$y_1 = 4x(4 - x)$, $y_2 = 5(x - 2)^2$, $a = \frac{2}{3}$ and

$b = \frac{10}{3}$.

Expand the brackets and simplify.

$$\begin{aligned}
 &= \int_{\frac{2}{3}}^{\frac{10}{3}} 16x - 4x^2 - 5(x^2 - 4x + 4) dx
 \end{aligned}$$

dx

$$\begin{aligned}
 &= \int_{\frac{2}{3}}^{\frac{10}{3}} 16x - 4x^2 - 5x^2 + 20x - 20 dx \quad \text{Remember } \int ax^n dx = \frac{ax^{n+1}}{n+1}
 \end{aligned}$$

$$\begin{aligned}
 &= \int_{\frac{2}{3}}^{\frac{10}{3}} 36x - 9x^2 - 20 dx
 \end{aligned}$$

$$\begin{aligned}
 &= \left[18x^2 - 3x^3 - 20x \right]_{\frac{2}{3}}^{\frac{10}{3}}
 \end{aligned}$$

Evaluate the integral. Substitute $x = \frac{10}{3}$, then $x =$

$\frac{2}{3}$, into $18x^2 - 3x^3 - 20x$ and subtract.

$$\begin{aligned}
 &= \left(18 \left(\frac{10}{3} \right)^2 - 3 \left(\frac{10}{3} \right)^3 - 20 \left(\frac{10}{3} \right) \right)
 \end{aligned}$$

$$\left(\frac{10}{3} \right)$$

$$\begin{aligned}
 &\quad - \left(18 \left(\frac{2}{3} \right)^2 - 3 \left(\frac{2}{3} \right)^3 - 20 \left(\frac{2}{3} \right) \right)
 \end{aligned}$$

$$\left(\frac{2}{3} \right)$$

$$\begin{aligned}
 &= \left(18 \left(\frac{100}{9} \right) - 3 \left(\frac{1000}{27} \right) - \right.
 \end{aligned}$$

$$\left. \frac{200}{3} \right)$$

$$\begin{aligned}
 &\quad - \left(18 \left(\frac{4}{9} \right) - 3 \left(\frac{8}{27} \right) - \frac{40}{3} \right)
 \end{aligned}$$

$$\begin{aligned}
 &= \left(22 \frac{2}{9} \right) - \left(-6 \frac{2}{9} \right)
 \end{aligned}$$

$$\begin{aligned}
 22 \frac{2}{9} - \left(-6 \frac{2}{9} \right) &= 22 \frac{2}{9} + 6 \frac{2}{9}
 \end{aligned}$$

$$\begin{aligned}
 &= 28 \frac{4}{9}
 \end{aligned}$$

$$\begin{aligned}
 &= 28 \frac{4}{9}
 \end{aligned}$$

Solutionbank C1

Edexcel Modular Mathematics for AS and A-Level

Algebra and functions

Exercise A, Question 25

Question:

The volume of a solid cylinder, radius r cm, is 128π .

(a) Show that the surface area of the cylinder is given by $S = \frac{256\pi}{r} + 2\pi r^2$.

(b) Find the minimum value for the surface area of the cylinder.

Solution:

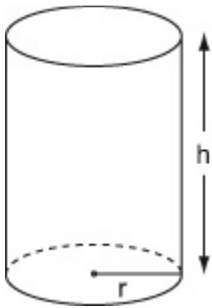

Draw a diagram. Let h be the height of cylinder.

(a)

Surface area, $S = 2\pi rh + 2\pi r^2$
(volume =) $128\pi = \pi r^2 h$

$$\begin{aligned} h &= \frac{128\pi}{\pi r^2} \\ &= \frac{128}{r^2} \end{aligned}$$

$$\begin{aligned} \text{so } S &= 2\pi r \times \frac{128}{r^2} + 2\pi r^2 \\ &= \frac{256\pi}{r} + 2\pi r^2 \text{ (as required)} \end{aligned}$$

Find expressions for the surface area and volume of the cylinder in terms of π , r and h .

Eliminate h between the expressions $S = 2\pi rh + 2\pi r^2$ and $128\pi = \pi r^2 h$. Rearrange $128\pi = \pi r^2 h$ for h so that

$$\begin{aligned} \pi r^2 h &= 128\pi \\ h &= \frac{128\pi}{\pi r^2} \\ &= \frac{128}{r^2} \end{aligned}$$

Substitute $h = \frac{128}{r^2}$ into $S = 2\pi rh + 2\pi r^2$ and simplify the expression.

(b)

$$\frac{ds}{dr} = 4\pi r - \frac{256\pi}{r^2}$$

Find the value of r for which $S = \frac{256\pi}{r} + 2\pi r^2$ has a stationary value. Solve $\frac{ds}{dr} = 0$. Differentiate

$\frac{256\pi}{r} + 2\pi r^2$ with respect to r , so that

$$4\pi r - \frac{256\pi}{r^2} = 0$$

$$4\pi r = \frac{256\pi}{r^2}$$

$$r^3 = 64$$

$$r = 4 \text{ cm}$$

$$\frac{d}{dr} \left(\frac{256\pi}{r} \right) = \frac{d}{dr} 256\pi r^{-1}$$

$$= -256\pi r^{-1-1}$$

$$= -256\pi r^{-2}$$

$$= \frac{-256\pi}{r^2}$$

$$\frac{d}{dr} (2\pi r^2) = 2 \times 2\pi r^{2-1}$$

$$= 4\pi r^1$$

$$= 4\pi r$$

When $r = 4$,

$$S = \frac{256\pi}{(4)} + 2\pi (4)^2$$

$$= 64\pi + 32\pi$$

$$= 96\pi \text{ cm}^2$$

Find the value of S when $r = 4$. Substitute $r = 4$ into $S =$

$$\frac{256\pi}{r} + 2\pi r^2.$$

Give the exact answer. Leave your answer in terms of π .

Solutionbank C1

Edexcel Modular Mathematics for AS and A-Level

Algebra and functions

Exercise A, Question 26

Question:

The diagram shows part of the curve $y = \sin(ax - b)$, where a and b are constants and $b < \frac{\pi}{2}$.

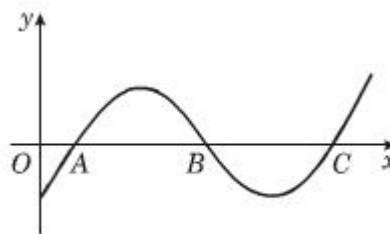

Given that the coordinates of A and B are $(\frac{\pi}{6}, 0)$ and $(\frac{5\pi}{6}, 0)$ respectively,

- (a) write down the coordinates of C ,
- (b) find the value of a and the value of b .

Solution:

(a)

$$AB = BC$$

$$\begin{aligned} AB &= \frac{5\pi}{6} - \frac{\pi}{6} \\ &= \frac{4\pi}{6} \\ &= \frac{2\pi}{3} \end{aligned}$$

$$\begin{aligned} \text{so, } OC &= \frac{5\pi}{6} + \frac{2\pi}{3} \\ &= \frac{5\pi}{6} + \frac{4\pi}{6} \\ &= \frac{9\pi}{6} \\ &= \frac{3\pi}{2} \end{aligned}$$

$$\text{so, } C\left(\frac{3\pi}{2}, 0\right)$$

(b)

(i)

$$\sin\left(a\left(\frac{\pi}{6}\right) - b\right) = 0$$

$$\text{so } a\left(\frac{\pi}{6}\right) - b = 0$$

AB is half the period, so $AB = BC$

Find the coordinates of C . Work out the length of AB , $AB = OB - OA$. Work with exact values. Leave your answer in terms of π .

$OC = OB + BC$ and $AB = BC$. So, $OC = OB + AB$.

$\sin(0) = 0$ and $\sin(\pi) = 0$. So, at A , $x = \frac{\pi}{6}$ and a

$$\frac{\pi}{6}) - b = 0 \text{ and at B, } x = \frac{5\pi}{6} \text{ and } a\left(\frac{5\pi}{6}\right) - b = \pi.$$

(ii)

$$\sin\left(a\left(\frac{5\pi}{6}\right) - b\right) = 0$$

$$\text{so } a\left(\frac{5\pi}{6}\right) - b = \pi$$

Solving Simultaneously

$$a\left(\frac{5\pi}{6}\right) - b = \pi$$

$$-a\left(\frac{\pi}{6}\right) - b = 0$$

$$a\left(\frac{4\pi}{6}\right) = \pi$$

$$a = \frac{\pi}{\left(\frac{4\pi}{6}\right)}$$

$$= \frac{6}{4}$$

$$= \frac{3}{2}$$

$$\text{When } a = \frac{3}{2}$$

$$\left(\frac{3}{2}\right)\left(\frac{\pi}{6}\right) - b = 0$$

$$b = \frac{\pi}{4}$$

check

$$\text{sub } a = \frac{3}{2}, b = \frac{\pi}{4} \text{ into}$$

$$a\left(5\frac{\pi}{6}\right) - b$$

$$\left(\frac{3}{2}\right)\left(\frac{5\pi}{6}\right) - \frac{\pi}{4} = \frac{5\pi}{4} - \frac{\pi}{4} \\ = \pi \text{ (as required)}$$

$$\text{so } a = \frac{3}{2} \text{ and } b = \frac{\pi}{4}.$$

Solve the equations $a\left(\frac{\pi}{6}\right) - b = 0$ and $a\left(\frac{5\pi}{6}\right) - b = \pi$ simultaneously. Subtract the equations.

Find b . Substitute $a = \frac{3}{2}$ into $a\left(\frac{\pi}{6}\right) - b = 0$.

Check answer by substituting $a = \frac{3}{2}$ and $b = \frac{\pi}{4}$ into $a\left(\frac{5\pi}{6}\right) - b$.

$$\left(\frac{3}{2}\right)\left(\frac{5\pi}{6}\right) - \frac{\pi}{4} = \frac{1}{2} \times \frac{5\pi}{2} - \frac{\pi}{4}$$

Solutionbank C1

Edexcel Modular Mathematics for AS and A-Level

Algebra and functions

Exercise A, Question 27

Question:

Find the area of the finite region bounded by the curve with equation $y = x(6 - x)$ and the line $y = 10 - x$.

Solution:

$$y = x(6 - x), \quad y = 10 - x$$

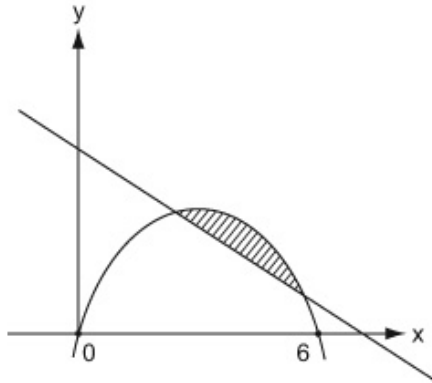

$$x(6 - x) = 10 - x$$

$$6x - x^2 = 10 - x$$

$$x^2 - 7x + 10 = 0$$

$$(x - 5)(x - 2) = 0$$

so $x = 2$ and $x = 5$.

$$\text{Finite area} = \int_2^5 x(6 - x) - (10 - x) dx$$

$$= \int_2^5 6x - x^2 - 10 + x dx$$

$$= \int_2^5 7x - x^2 - 10 dx$$

$$= \left[\frac{7x^2}{2} - \frac{x^3}{3} - 10x \right]_2^5$$

$$= \left(\frac{7(5)^2}{2} - \frac{(5)^3}{3} - 10 \left(\frac{5^3}{3} \right) - 10x \right) \text{ and subtract.}$$

$$- \left(\frac{7(2)^2}{2} - \frac{(2)^3}{3} - 10 \right)$$

$$(2)$$

$$= \left(-4 \frac{1}{6} \right) - \left(-8 \frac{2}{3} \right) - 4 \frac{1}{6} - \left(-8 \frac{2}{3} \right) = -4 \frac{1}{6} + 8 \frac{2}{3}$$

$$= 4 \frac{1}{2}$$

$$= 4 \frac{1}{2}$$

Find the x -coordinates of the points where the line $y = 10 - x$ meets the curve $y = x(6 - x)$. Solve the equations simultaneously, eliminate y .

Factorise $x^2 - 7x + 10$. $(-5) \times (-2) = 10$ and $(-5) + (-2) = -7$ so $x^2 - 7x + 10 = (x - 5)(x - 2)$.

Use area = $\int_a^b (y_1 - y_2) dx$. Have $y_1 = x(6 - x)$, $y_2 = 10 - x$, $a = 2$ and $b = 5$.

Remember $\int ax^n dx = \frac{ax^{n+1}}{n+1}$

Evaluate the integral. Substitute $x = 5$, then $x = 2$, into $\frac{7x^2}{2} -$

Solutionbank C1

Edexcel Modular Mathematics for AS and A-Level

Algebra and functions

Exercise A, Question 28

Question:

A piece of wire of length 80 cm is cut into two pieces. Each piece is bent to form the perimeter of a rectangle which is three times as long as it is wide. Find the lengths of the two pieces of wire if the sum of the areas of the rectangles is to be a maximum.

Solution:

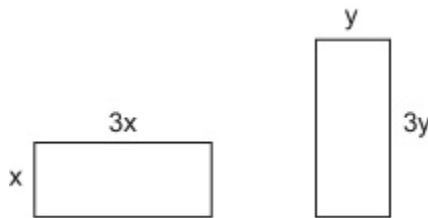

Total length of wire = 80

$$\text{so } 80 = 8x + 8y$$

$$x + y = 10$$

Total Area = A

$$A = 3x^2 + 3y^2$$

$$\begin{aligned} A &= 3x^2 + 3(10 - x)^2 \\ &= 3x^2 + 3(100 - 20x + x^2) \\ &= 3x^2 + 300 - 60x + 3x^2 \\ &= 6x^2 - 60x + 300 \end{aligned}$$

$$\frac{dA}{dx} = 12x - 60$$

$$12x - 60 = 0$$

$$12x = 60$$

$$x = 5 \text{ cm}$$

The length of each piece of wire is
($8x =$) 40 cm .

Draw a diagram. Let the width of each rectangle be x and y respectively.

Write down an equation in terms of x and y for the total length of the wire.

Divide throughout by 8.

Write down an equation in terms of x and y for the total area enclosed by the two pieces of wire.

Solve the equations $x + y = 10$ and

$A = 3x^2 + 3y^2$ simultaneously. Eliminate y . Rearrange $x + y = 10$, so that $y = 10 - x$, and substitute into

$$A = 3x^2 + 3y^2$$

Find the value of x for which A is a maximum. Solve

$$\frac{dA}{dx} = 0.$$

Total length is 80 cm, so $40 + 40 = 80$

Solutionbank C1

Edexcel Modular Mathematics for AS and A-Level

Algebra and functions

Exercise A, Question 29

Question:

The diagram shows the shaded region C which is bounded by the circle $y = \sqrt{1 - x^2}$ and the coordinate axes.

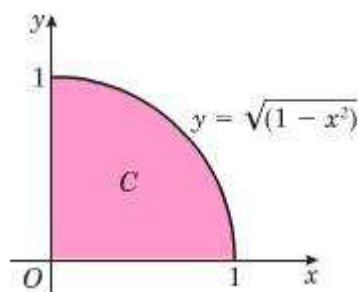

(a) Use the trapezium rule with 10 strips to find an estimate, to 3 decimal places, for the area of the shaded region C .

The actual area of C is $\frac{\pi}{4}$.

(b) Calculate the percentage error in your estimate for the area of C .

Solution:

$$\text{Remember } A \approx \frac{1}{2}h [y_0 + 2(y_1 + y_2 + \dots) + y_n]$$

x	0	0.1	0.2	0.3	0.4	0.5	0.6	0.7	0.8	0.9	1
$\sqrt{1 - x^2}$	1	0.9950	0.9798	0.9539	0.9165	0.8660	0.8	0.7141	0.6	0.4359	0

$$\text{Area} \approx \frac{1}{2} \times 0.1 \times [1 + 2(0.9950 + 0.9798 + \dots + 0.4359) + 0]$$

$$\approx 0.77612 \text{ or } 0.776$$

Divide the interval into 10 equal strips. Use $h = \frac{b-a}{n}$. Here $a = 0$, $b = 1$ and $n = 10$, so that $\frac{1-0}{10} = \frac{1}{10} = 0.1$

The trapezium rule gives an approximation to the area under the graph. Here we round to 4 decimal places.

The values of $\sqrt{1 - x^2}$ are rounded to 4 decimal place. Give your final answer to 3 decimal places.

(b)

$$\frac{\pi}{4} =$$

$$\begin{aligned}\% \text{ error} &= \frac{\frac{\pi}{4} - 0.776}{\left(\frac{\pi}{4}\right)} \times 100 \\ &= 1.2 \%\end{aligned}$$

$$\text{Use percentage error} = \frac{\text{True value}}{\text{True value}} \times 100$$

© Pearson Education Ltd 2008

Solutionbank C1

Edexcel Modular Mathematics for AS and A-Level

Algebra and functions

Exercise A, Question 30

Question:

The area of the shaded region A in the diagram is 9 cm^2 . Find the value of the constant a .

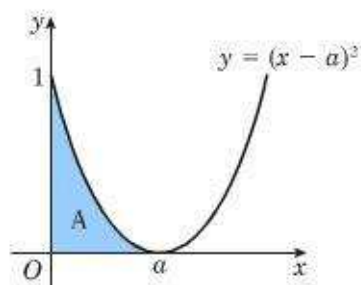

Solution:

$$\int_0^a (x - a)^2 dx = 9$$

$$\int_0^a x^2 - 2ax + a^2 dx = 9$$

$$\left[\frac{x^3}{3} - ax^2 + a^2x \right]_0^a = 9$$

$$\left(\frac{a^3}{3} - a(a)^2 + a^2(a) \right)$$

–

$$\left(\frac{(0)^3}{3} - a(0)^2 + a^2(0) \right)$$

$$= 9$$

$$\left(\frac{a^3}{3} - a^3 + a^3 \right) - 0 = 9$$

$$\frac{a^3}{3} = 9$$

$$a^3 = 27$$

$$a = 3$$

Write down an equation in terms of a for the area of region A.

Expand $(x - a)^2$ so that

$$\begin{aligned} (x - a)(x - a) &= x^2 - ax - ax + a^2 \\ &= x^2 - 2ax + a^2 \end{aligned}$$

Remember $\int ax^n dx = \frac{ax^{n+1}}{n+1}$.

Here

$$\int x^2 dx = \frac{x^3}{3}$$

$$\int 2ax dx = \frac{2ax^2}{2}$$

$$= ax^2$$

$$\int a^2 dx = a^2x$$

Evaluate the integral. Substitute $x = a$, then $x = 0$, into

$\frac{x^3}{3} - ax^2 + a^2x$, and subtract.

